

E326e

**ENERPAC** 

Powerful Solutions.  
Global Force.

**TIFOR Kft.**

**Attila u. 101.**

**1012 Budapest**

tel 06 1 **212 99 58**

fax 06 1 **375 49 79**

eMail **info@tifor.hu**

**www.tifor.hu**



# Table of Contents

<b>Introduction</b>		
The World Class Brand	2-3	
<b>Cylinders &amp; Lifting Products</b>	<b>4 - 63</b>	
Hydraulic Cylinders Introduction	4 - 5	
RC-Series, Single-Acting, General Purpose Cylinders	6 - 9	
Cylinder Accessories	10	
RAC-Series, Single-Acting, Aluminium Cylinders	12 - 13	
RACL-Series, Single-Acting, Aluminium Lock Nut Cylinders	14 - 15	
RACH-Series, Single-Acting, Aluminium Hollow Plunger Cylinders	16 - 17	
RAR-Series, Double-Acting, Aluminium Cylinders	18 - 19	
CLP-Series, Single-Acting, Pancake Lock Nut Cylinders	20 - 21	
RSM, RCS-Series, Single-Acting, Low Height Cylinders	22 - 23	
BRC, BRP-Series, Single-Acting, Pull Cylinders	24 - 25	
RCH-Series, Single-Acting, Hollow Plunger Cylinders	26 - 27	
RRH-Series, Double-Acting, Hollow Plunger Cylinders	28 - 29	
BRD-Series, Double-Acting, Precision Production Cylinders	30 - 31	
RR-Series, Double-Acting, Long Stroke Cylinders	32 - 35	
CLSG-Series, Single-Acting, High Tonnage Cylinders	36 - 37	
CLSG-Series, Single-Acting, High Tonnage Cylinders	38 - 39	
CLS-Series, Single-Acting, High Tonnage Cylinders	40 - 41	
CLS-Series, Single-Acting, High Tonnage Cylinders	42 - 43	
CLRG-Series, Double-Acting, High Tonnage Cylinders	44 - 45	
CLRG-Series, Double-Acting, High Tonnage Cylinders	46 - 47	
CLL-Series, Single-Acting, Lock Nut Cylinders	48 - 49	
CLL-Series, Single-Acting, Lock Nut Cylinders	50 - 51	
LB-Series, Lifting Bags	52 - 53	
LPC-Series, Resin Cribbing Blocks	54 - 55	
JH, JHA-Series, Aluminium and Steel Jacks	56	
EBJ-Series, Steel Bottle Jacks	57	
PR-Series, POW'R-RISER® Lifting Jacks	58 - 59	
Extreme Environment Products	60 - 61	
SC-Series, Cylinder-Pump Sets	62 - 63	
<b>Pumps &amp; Directional Control Valves</b>	<b>64 - 117</b>	
Hydraulic Pumps Introduction	64 - 65	
P-Series, Lightweight Hand Pumps	66 - 67	
P-Series, Steel Hand Pumps	68 - 69	
P-Series, Low Pressure Hand Pumps	70 - 71	
MP-Series, Multifluid Hand Pumps	72	
P-Series, Foot Pump	73	
P, 11-Series, Ultra-High Pressure Hand Pumps	74 - 75	
BP-Series, Battery Powered Pumps	76 - 77	
PU-Series, Economy Electric Pumps	78 - 79	
PE-Series, Submerged Electric Pumps	80 - 83	
Z-Class Power Pumps Introduction	84 - 85	
ZU4-Series, Portable Electric Pumps	86 - 91	
ZE-Series, Electric Pumps	92 - 97	
PP-8000 and 9000-Series, Electric Pumps	98 - 99	
XA-Series, Air Driven Foot Pumps	100 - 101	
PAT-Series, Turbo II, Air Hydraulic Pumps	102 - 103	
PA-Series, Air Hydraulic Foot Pumps	104	
PAM-Series, Air Hydraulic Pumps	105	
ZA4-Series, Modular Air Hydraulic Pumps	106 - 107	
ATP-Series, Ultra-High Pressure Air Pump	108	
PGM-Series, Gasoline Hydraulic Pumps	109	
ZG-Series, Gasoline Hydraulic Pumps	110 - 112	
<b>Directional Control Valves</b>	<b>113 - 117</b>	
VM, VE-Series, Pump Mounted Valves	114 - 115	
VC-Series, Remote Mounted Valves	116	
Valves Dimensions	117	
<b>System Components &amp; Control Valves</b>	<b>118 - 135</b>	
System Components Introduction	118 - 119	
H700-Series, High Pressure Hoses	120 - 121	
A, C, F, T-Series, Hydraulic Couplers	122 - 123	
HF-Series, Hydraulic Oil	124	
A, AM-Series, Manifolds	124 - 125	
FZ, BFZ-Series, Fittings	125	
GF, GP-Series, Force & Pressure Gauges	126 - 127	
G, H-Series, Pressure Gauges	128 - 129	
T-Series, Test System Gauges	130	
DGR-Series, Digital Pressure Gauges	131	
GA, NV, V-Series, Gauge Accessories	132	
V-Series, Pressure & Flow Control Valves	134 - 135	
<b>Hydraulic Presses</b>	<b>136 - 147</b>	
Hydraulic Presses Introduction	136 - 137	
XLP, VLP-Series, Bench & Workshop Presses	138 - 139	
BPR-Series, Roll-Frame Presses	140 - 141	
A-Series, C-Clamp and Arbor Presses	142 - 143	
BV-Series, Bench Vise	144 - 145	
TM, LH-Series, Tension Meter & Load Cells	147	
<b>Pullers</b>	<b>148 - 162</b>	
Pullers Introduction	148 - 149	
BHP-Series, Master Puller Sets	150	
BHP-Series, Grip Puller Sets	151	
BHP-Series, Cross Bearing Puller Sets	152	
BHP-Series, Bearing Cup and Bearing Pullers	153	
EP-Series, Posi Lock® Mechanical Grip Pullers	154 - 157	
EPH-Series, Posi Lock® Hydraulic Pullers	158 - 159	
Posi Lock® Hydraulic Puller Accessories	160	
EPH-Series, Posi Lock® 100 Ton Hydraulic Grip Pullers	161	
<b>Tools</b>	<b>162 - 183</b>	
Hydraulic Tools Introduction	162 - 163	
MS-Series, Maintenance Sets	164 - 167	
SP-Series, Lightweight Hydraulic Punch	168 - 169	
SP-Series, 50 Ton Double-Acting Punch	170 - 171	
LW-Series, Hydraulic Vertical Lifting Wedge	172	
SOH-Series, Hydraulic Machine Lifts	173	
ER-Series, Heavy Duty Caterroller™ Load Skates	174 - 175	
CM-Series, Industrial Storage Cases	176	
A, WR-Series, Hydraulic Wedgie & Spread Cylinders	177	
WHC-Series, Hydraulic Cutterheads	178	
WMC-Series, Self-Contained Hydraulic Cutters	179	
STB-Series, Pipe Bender Sets	180 - 181	
PTJ, 5DA-Series, Mono-Strand Stressing Tools	182 - 183	
<b>Bolting Tools</b>	<b>184 - 221</b>	
Bolting Tools Introduction	184	
E-Series, Manual Torque Multipliers	186 - 187	
S-Series, Square Drive Torque Wrenches	188 - 191	
BSH-Series, Heavy-Duty Sockets	192	
W-Series, Low Profile Hexagon Wrenches	194 - 201	
PMU-Series, Portable Electric Torque Wrench Pumps	203	
ZU4T-Series, Electric Torque Wrench Pumps	204 - 207	
ZE-Series, Electric Torque Wrench Pumps	208 - 209	
PTA-Series, Compact Pneumatic Torque Wrench Pump	210 - 211	
ZA4T-Series, Air Driven Torque Wrench Pumps	212 - 215	
ATM-Series, Flange Alignment Tools	216	
FSH, FSM-Series, Wedge Spreaders	217	
FS-Series, Hydraulic Flange Spreaders	218	
NC-Series, Hydraulic Nut Splitters	219	
NS-Series, Hydraulic Nut Splitters	220 - 221	
<b>Integrated Solutions</b>	<b>222 - 238</b>	
Integrated Solutions Introduction	222 - 223	
ESS-Series, Standard 4-16 Point Synchronous Lifting System	224 - 225	
EPS-Series, Premium 4-64 Point Synchronous Lifting System	226 - 227	
TT-Series, Heavy Lifting Strand Jacks	228 - 229	
Strand Jack Pumps & Controls	230 - 231	
BLS-Series, Stage-Lift Cylinders	232 - 233	
SHS-Series, SyncHoist	234 - 235	
B, M-Series, Uni-Lift® Mechanical Actuators	236 - 238	
<b>Yellow Pages</b>	<b>239 - 254</b>	
Yellow Pages Overview	239	
Safety Instructions	240 - 241	
Pump Selection and Selection Worksheet	242-243	
Basic System Set-ups	244 - 245	
Basic Hydraulics	246 - 247	
Conversion Tables	248	
Cylinder Speed Charts	249	
Valve Information	250	
Global Warranty Policy	251	
Torque Tightening	252 - 253	
Hexagon Nut and Bolt Sizes	254	
<b>About Enerpac</b>	<b>255</b>	
<b>Enerpac Worldwide Locations</b>	<b>256</b>	
<b>Model Number Index</b>	<b>257</b>	



# Model Number Index

# Section Index

Page(s) ▼ Page(s) ▼ Page(s) ▼ Page(s) ▼

<b>A</b>	<b>D</b>	<b>N</b>	<b>STF</b> .....
A5-A10 .....	DGR .....	NC .....	217-218
A12 .....	131	NS .....	219
A13-A28 .....	<b>E</b>	220-221	<b>STN</b> .....
166	E .....	132	169
A29-A53 .....	186-187	<b>P</b>	<b>STV</b> .....
10	EBJ .....	P .....	144
A64-A66 .....	57	66-71, 73	<b>SW</b> .....
A92 .....	ELP .....	74-75	217
166, 177	EMB .....	60-61	<b>T</b>
A102 .....	174-175	P142AL .....	T .....
10	EP .....	60-61	123, 130
A128-A192 .....	154-157	P392AL .....	TH .....
166	EPH .....	73	194, 202-203
A183 .....	158-161	PA .....	207, 209-214
A185 .....	EPP .....	102-104	<b>TM</b> .....
142, 166	EPS .....	PAM .....	147
A200R .....	226-227	PAMG .....	<b>TW</b> .....
A205-A220 .....	EPT .....	102-103	216
142	EPX .....	PATG .....	<b>V</b>
A218 .....	ER .....	102-103	V .....
166	ES .....	PARG .....	60-61, 134-135
A242-A305 .....	ESS .....	66, 68, 70	<b>VA2</b> .....
166	224-225	PE .....	105
A310, A330 .....	<b>F</b>	80-83	<b>VB</b> .....
142	F .....	94	139, 146
A530-A595 .....	122-123	PGM .....	<b>VC</b> .....
166	FH .....	109	116-117
A604 .....	FR .....	PM .....	<b>VE</b> .....
122-123	122-123	PP .....	114-117
A607 .....	FS .....	PR .....	<b>VHJ</b> .....
166	218	PTJ .....	146
A630 .....	FSB .....	182-183	<b>VLP</b> .....
122-123	172, 217	PTA .....	138-139
A650 .....	FSH .....	202, 210-211	<b>VM</b> .....
166	217	PU .....	114-117
AH .....	FSM .....	78-79	<b>W</b>
122-123	FZ .....	<b>R</b>	W .....
AM .....	125	RA .....	194-201
124	<b>G</b>	RAC .....	<b>WC</b> .....
AR .....	GA .....	12-13	178-179
122-123	126-127	RACH .....	<b>WH</b> .....
ATM .....	GF .....	16-17	178
216	GP .....	RACL .....	<b>WM</b> .....
ATP .....	126-127	RAR .....	179
208	<b>H</b>	RB .....	<b>WR</b> .....
AW .....	H .....	6-9, 60-61	167, 177
10	120-121	RCH .....	<b>WRP</b> .....
<b>B</b>	132-133	RCS .....	201
B .....	HA .....	RE .....	<b>WTE</b> .....
108, 236-238	121	RFL .....	201
<b>BAD</b> .....	HB .....	101-105	<b>X</b>
31	HC .....	32-35	XA .....
<b>BFZ</b> .....	HF .....	28-29	100-101
125	HP .....	22-23	<b>XLK</b> .....
<b>BH</b> .....	HT .....	191	100
108	<b>I</b>	RWH .....	<b>XLP</b> .....
<b>BHP</b> .....	IPL .....	150	138-139
150-153	146	<b>S</b>	<b>XPG</b> .....
<b>BLS</b> .....	<b>J</b>	S .....	100, 125
232-233	JBI .....	188-191	<b>Z</b>
<b>BP</b> .....	JH .....	172, 217	Z .....
76-77	56	88, 94	123
<b>BPR</b> .....	<b>L</b>	206, 214	<b>ZA4</b> .....
140-141	LB .....	62-63	106-107
<b>BR</b> .....	LH .....	182-183	202
108	147	SDA .....	212-215
<b>BRC</b> .....	LPC .....	190	<b>ZC</b> .....
24-25	54-55	SHS .....	88, 94-95
<b>BRD</b> .....	LW .....	56-57	<b>ZE</b> .....
30-31	172	SLS .....	92-97
<b>BRP</b> .....	<b>M</b>	54-55	208-209
24-25	M .....	SOH .....	208-209
<b>BSH</b> .....	236-238	SP .....	<b>ZG</b> .....
192	MP .....	168-171	110-112
<b>BSS</b> .....	72	SPD .....	<b>ZH</b> .....
92, 106, 146	MS .....	169	89, 95, 206
<b>BV</b> .....	MSP .....	168	<b>ZL</b> .....
144-145	169	SRS .....	88, 94
<b>BW</b> .....	MZ .....	180-181	<b>ZP</b> .....
108	164-167	217-218	89, 94
<b>BZ</b> .....	<b>10</b>	<b>5DA</b> .....	<b>ZU4</b> .....
180-181	182-183	182-183	86-91
<b>C</b>	<b>11</b> .....	74-75	<b>ZU4T</b> .....
C .....	74-75	183	202
<b>CAT</b> .....	<b>40</b> .....	183	204-206
10, 23, 39	41-43-45 .....	75	<b>ZR</b> .....
43, 47, 51	72-75 .....	75	88, 94, 214
<b>CATG</b> .....	<b>72</b> .....	75	<b>83-</b> .....
13, 15, 19	74-75 .....	75	
39, 47	<b>83-</b> .....	75	
<b>CD</b> .....			
123			
<b>CH</b> .....			
123			
<b>CLL</b> .....			
48-51			
<b>CLP</b> .....			
20-21			
<b>CLRG</b> .....			
44-47			
<b>CLS</b> .....			
40-43			
<b>CLSG</b> .....			
36-39			
<b>CM</b> .....			
176			
<b>CR</b> .....			
122-123			
<b>CW</b> .....			
166			

## Cylinders & Lifting Products



Page 4-63

## Pumps & Directional Control Valves



Page 64-117

## System Components & Control Valves



Page 118-135

## Presses



Page 136-147

## Pullers



Page 148-161

## Tools



Page 162-183

## Bolting Tools



Page 184-221

## Integrated Solutions



Page 222-238

**A** complete range of quality high force tools for all industrial applications, with local availability and after sale service anywhere in the world.... this is what has made Enerpac the undisputed global market leader in high pressure hydraulics.

Across every continent, Enerpac's network of authorized distributors and service centers can reach even the most remote locations, supplying and servicing products that are designed to enhance productivity and performance, while making the workplace safer.

With over 150 sales specialists and a network of service and engineering support in 17 countries across the globe, Enerpac has become the product of choice in industries such as manufacturing, construction, energy, oil & gas, shipbuilding, railroads, mining, and metals transformation.

Always at the leading edge of technology, Enerpac has continued to develop its range of time and cost-savings tools, utilizing modern engineered materials to improve productivity and minimize operator fatigue.

Enerpac's commitment to the continued development of quality high force tools ensures that the products you purchase are the best tools in the industry.

We will continue to lead the way in the development of quality high force tools for all industrial applications.





# Class Brand

## 10 Reasons to Work with Enerpac

- Expert Design
- Highly Reliable
- Service Excellence
- Worldwide Experience
- Application Support
- Availability
- Quality
- Value
- Innovative Products
- Systems Solutions



### Total Quality

Our products are tested to the most exacting standards. These high standards guarantee the quality, price and performance requirements of the markets we serve around the globe.

### Global Network

Enerpac has an extensive network of authorized distributors and service centers located in more than 90 countries worldwide. You can rely on Enerpac for the products and technical support you need to get your job done, anywhere in the world.

### Logistics Excellence

Enerpac's mission is to maintain service excellence in the ever-changing world of modern distribution. Providing our extensive range of products to our thousands of distributors worldwide demands a logistic expertise only a market leader can provide.



### A Tradition of Innovation

Enerpac has a long history of finding new solutions to better meet the challenges of the industries we serve. We were the first to develop a composite hand pump and the first to offer a computerized lifting system. Our latest innovations include the new XA-Series of air driven foot pumps, designed for less operator fatigue – with the unique XVARI® Technology, delivering variable oil flow and fine metering for precise control, a full range of aluminium cylinders with the strength of steel and the advantages of aluminium and the Z-Class series of power pumps ... pumps that were designed to run cooler, use less electricity and are easy to service.

To support the demands of the construction industry, Enerpac continues to develop Integrated Solutions capabilities. These capabilities include controlled hydraulic movement for your most challenging applications.

**ENERPAC**   
POWERFUL SOLUTIONS. GLOBAL FORCE.

ENERPAC hydraulic cylinders are available in hundreds of different configurations. Whatever the industrial application... lifting, pushing, pulling, bending, holding... whatever the force capacity, stroke length, or size restrictions... single- or double-acting, solid or hollow plunger, you can be sure that Enerpac has the cylinder to suit your high force application. Enerpac jacking cylinders fully comply to ASME B30.1.

*(except BRD-Series)*



### Golden Ring Design

The exclusive Golden Ring Design is a unique bearing design which absorbs eccentric load stresses to protect your cylinder against abrasion, over-extending or plunger blow-outs and jamming or top-end mushrooming. As a result, Golden Ring cylinders provide long, trouble-free operation.

### Hardened Saddle

prevents plunger from mushrooming and jamming in the top bearing. Snap-in design.

### Plunger Wiper

reduces contamination, extending cylinder life.

### Golden Ring

absorbs eccentric loading without galling cylinder parts.

### Plated Plunger

resists wear and rust.

### Golden Ring

absorbs eccentric loading without galling cylinder parts.

### Plunger Return Spring



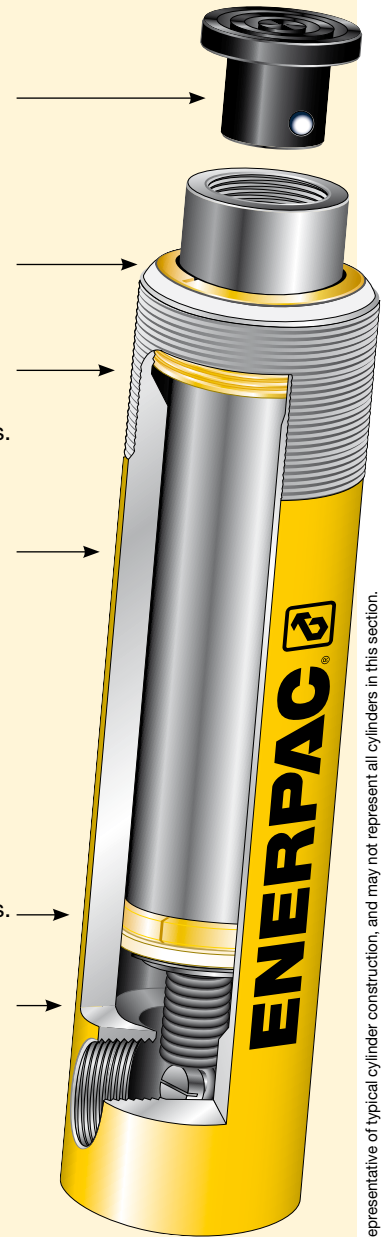





























enables fast plunger retraction on single-acting cylinders.



Note: The cut-away drawing is representative of typical cylinder construction, and may not represent all cylinders in this section.



# Cylinders and Lifting Products Section Overview

Capacity <sup>1)</sup> ton (kN)	Stroke Range (mm)	Cylinder type and functions	Series	Page
<b>5 - 95</b> (45 - 933)	<b>16 - 362</b>	<b>General Purpose Cylinders, Single-Acting (incl. accessories)</b>	 RC	 <b>6</b> ▶
<b>20 - 150</b> (229 - 1589)	<b>50 - 200</b>	<b>Aluminium Cylinders, Single-Acting, Lock Nut Hollow Plunger, Double-Acting</b>	  RAC, RACL RACH RAR	 <b>12</b> ▶
<b>5 - 520</b> (45 - 5114)	<b>6 - 62</b>	<b>Pancake and Low Height Cylinders, Single-Acting</b>	  CLP RSM RCS	 <b>20</b> ▶ <b>22</b> ▶
<b>2,5 - 50</b> (24 - 505)	<b>127 - 155</b>	<b>Pull Cylinders, Single-Acting</b>	 BRC BRP	 <b>24</b> ▶
<b>13 - 145</b> (125 - 1429)	<b>8 - 258</b>	<b>Hollow Plunger Cylinders Single- and Double-Acting</b>	  RCH RRH	 <b>26</b> ▶ <b>28</b> ▶
<b>4 - 23</b> (35 - 222)	<b>28 - 260</b>	<b>Precision Production Cylinders Double-Acting (incl. mounting attachments)</b>	 BRD	 <b>30</b> ▶
<b>10 - 520</b> (101 - 5108)	<b>16 - 1219</b>	<b>Long Stroke Cylinders, Double-Acting</b>	 RR	 <b>32</b> ▶
<b>50 - 1000</b> (496 - 10260)	<b>50 - 300</b>	<b>High Tonnage Cylinders with integral stop ring, Single-Acting</b>	 CLSG CLS	 <b>36</b> ▶ <b>40</b> ▶
<b>50 - 1000</b> (496 - 10260)	<b>50 - 300</b>	<b>High Tonnage Cylinders, Double-Acting and Lock Nut Cylinder</b>	  CLRG CLL	 <b>44</b> ▶ <b>48</b> ▶
<b>3 - 74</b> (27 - 656)	-	<b>Lifting Bags</b>	LB	 <b>52</b> ▶
<b>36 - 54</b> (355 - 533)	-	<b>Resin Cribbing Blocks</b>	LPC	 <b>54</b> ▶
<b>1,4 - 150</b> (13-1335)	<b>76 - 508</b>	<b>Aluminium and Steel Jacks Bottle Jacks</b>	 JHA, JH EBJ	 <b>56</b> ▶ <b>57</b> ▶
<b>54 - 181</b> (533 - 1778)	<b>356 - 686</b>	<b>POW'R RISER® Lifting Jack</b>	 PR	 <b>58</b> ▶
<b>10 - 25</b> (101 - 232)	<b>54 - 158</b>	<b>High Temperature and Corrosion Resistant Cylinders Hand Pumps and Valves</b>	 RC P V	 <b>60</b> ▶
<b>5 - 95</b> (45 - 933)	<b>38 - 362</b>	<b>Cylinder - Pump Sets, Single-Acting</b>	 SC	 <b>62</b> ▶

<sup>1)</sup> All ton values specified in this catalog are metric ton and are for cylinder class identification only. Please refer to the kN data for calculations.

# RC-Series, Single-Acting Cylinders

▼ From left to right: RC-506, RC-50, RC-2510, RC-154, RC-10010, RC-55, RC-1010



- The exclusive Golden Ring design absorbs eccentric loading without galling cylinder parts
- Collar threads, plunger threads and base mounting holes enable easy fixturing (on most models)
- Designed for use in all positions
- High strength alloy steel for durability
- Nickel plating available on most models (contact Enerpac for details)
- Heavy duty return springs
- Baked enamel finish for increased corrosion resistance
- CR-400 coupler and dust cap included on all models
- Plunger wiper reduces contamination, extending cylinder life.

▼ Stage lifting set up in Greece, where assembled pipes, 25 meters in length, were stage lifted with six RC-2514 cylinders.



## The Industry Standard General Purpose Cylinder



### Saddles

All RC cylinders are equipped with hardened removable grooved saddles. For tilt and flat saddles, see the RC-Series accessory page.

Page: 10



### Base Plates

To ensure the stability of cylinders for lifting applications, base plates are available for 10, 25 and 50 ton RC cylinders.

Page: 10



### Specialty Attachments

For solving all kinds of application problems, specialty attachments are available for 5, 10 and 25 ton RC cylinders.

Page: 167

▼ RC cylinder mounting attachments greatly extend the application possibilities (available for 5, 10, 15 and 25 ton cylinders).





# Single-Acting, General Purpose Cylinders



## Golden Ring Design

The exclusive Golden Ring Design is a unique bearing design which absorbs eccentric load stresses to protect your cylinder against abrasion, over-extending or plunger blow-outs and jamming or top-end mushrooming. As a result, Golden Ring cylinders provide long, trouble-free operation.

### ▼ QUICK SELECTION CHART

For complete technical information see next page.

Cylinder Capacity	Stroke	Model Number	Cylinder Effective Area	Oil Capacity	Collapsed Height	
ton (kN)	(mm)		(cm <sup>2</sup> )	(cm <sup>3</sup> )	(mm)	(kg)
5 (45)	16	<b>RC-50**</b>	6,5	10	41	1,0
	25	<b>RC-51</b>	6,5	16	110	1,0
	76	<b>RC-53</b>	6,5	50	165	1,5
	127	<b>RC-55*</b>	6,5	83	215	1,9
	177	<b>RC-57</b>	6,5	115	273	2,4
10 (101)	232	<b>RC-59</b>	6,5	151	323	2,8
	26	<b>RC-101</b>	14,5	38	89	1,8
	54	<b>RC-102*</b>	14,5	78	121	2,3
	105	<b>RC-104</b>	14,5	152	171	3,3
	156	<b>RC-106*</b>	14,5	226	247	4,4
	203	<b>RC-108</b>	14,5	294	298	5,4
	257	<b>RC-1010*</b>	14,5	373	349	6,4
	304	<b>RC-1012</b>	14,5	441	400	6,8
15 (142)	356	<b>RC-1014</b>	14,5	516	450	8,2
	25	<b>RC-151</b>	20,3	51	124	3,3
	51	<b>RC-152</b>	20,3	104	149	4,1
	101	<b>RC-154*</b>	20,3	205	200	5,0
	152	<b>RC-156*</b>	20,3	308	271	6,8
	203	<b>RC-158</b>	20,3	411	322	8,2
	254	<b>RC-1510</b>	20,3	516	373	9,5
	305	<b>RC-1512</b>	20,3	619	423	10,9
25 (232)	356	<b>RC-1514</b>	20,3	723	474	11,8
	26	<b>RC-251</b>	33,2	86	139	5,9
	50	<b>RC-252*</b>	33,2	166	165	6,4
	102	<b>RC-254*</b>	33,2	339	215	8,2
	158	<b>RC-256*</b>	33,2	525	273	10,0
	210	<b>RC-258</b>	33,2	697	323	12,2
	261	<b>RC-2510</b>	33,2	867	374	14,1
	311	<b>RC-2512</b>	33,2	1033	425	16,3
30(295)	362	<b>RC-2514*</b>	33,2	1202	476	17,7
	209	<b>RC-308</b>	42,1	880	387	18,1
50 (498)	51	<b>RC-502</b>	71,2	362	176	15,0
	101	<b>RC-504</b>	71,2	719	227	19,1
	159	<b>RC-506*</b>	71,2	1131	282	23,1
	337	<b>RC-5013</b>	71,2	2399	460	37,6
75 (718)	156	<b>RC-756</b>	102,6	1601	285	29,5
	333	<b>RC-7513</b>	102,6	3417	492	59,0
95 (933)	168	<b>RC-1006</b>	133,3	2239	357	59,0
	260	<b>RC-10010</b>	133,3	3466	449	72,6

\* Available as set, see note on this page.

\*\* RC-50 cylinder has a non removable grooved saddle and no collar thread.

## RC Series



Capacity:

**5 - 95 ton**

Stroke:

**16 - 362 mm**

Maximum Operating Pressure:

**700 bar**



### Think Safety

Manufacturer's rating of load and stroke are maximum safe limits.

Good practice encourages using only 80% of these ratings.

Page: 240



### Lightweight Aluminium Cylinders

If you need a higher cylinder capacity-to-weight-ratio the **RAC-Series** are the perfect choice.

Page: 13



### Gauges

Minimize the risk of overloading and ensure long, dependable service from your equipment. Refer

to the System Components Section for a full range of gauges.

Page: 118

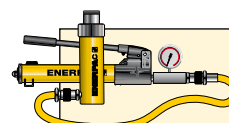

### Cylinder-Pump Sets

All cylinders marked with an \* are available as sets (cylinder, gauge, couplers, hose and pump) for your ordering convenience.

Page: 62

# RC-Series, Single-Acting Cylinders



### Speed Chart

See the Enerpac Cylinder Speed Chart in our 'Yellow Pages' to determine your approximate cylinder speed.

Page: **249**

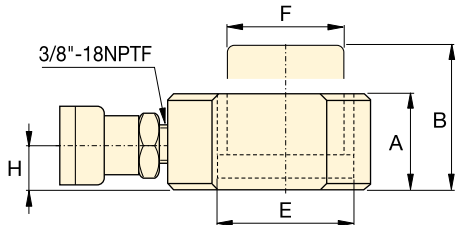
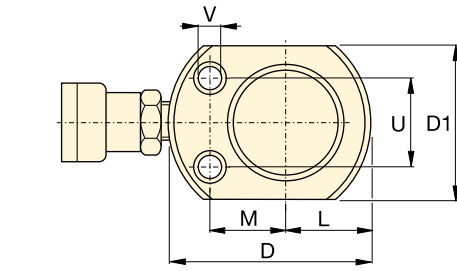

**RC-50**

**RC-101 only**  
(U1 = 19 mm)

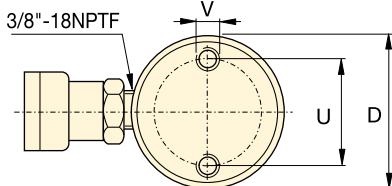
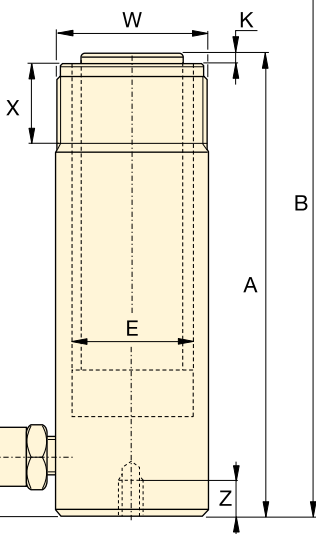
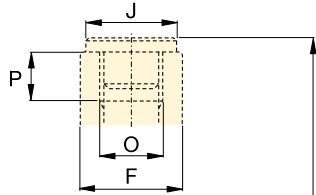
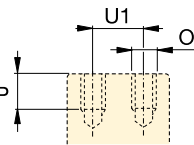

**RC-51 - RC-5013**

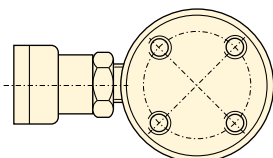

**RC-1006, RC-10010**

◀ For full features see previous page.

Cylinder Capacity	Stroke	Model Number	Cylinder Effective Area	Oil Capacity	Collapsed Height	Extended Height	Outside Dia.
ton (kN)	(mm)		(cm <sup>2</sup> )	(cm <sup>3</sup> )	A (mm)	B (mm)	D (mm)
<b>5</b> (45)	16	<b>RC-50**</b>	6,5	10	41	57	58***
	25	<b>RC-51</b>	6,5	16	110	135	38
	76	<b>RC-53</b>	6,5	50	165	241	38
	127	<b>RC-55*</b>	6,5	83	215	342	38
	177	<b>RC-57</b>	6,5	115	273	450	38
	232	<b>RC-59</b>	6,5	151	323	555	38
<b>10</b> (101)	26	<b>RC-101</b>	14,5	38	89	115	57
	54	<b>RC-102*</b>	14,5	78	121	175	57
	105	<b>RC-104</b>	14,5	152	171	276	57
	156	<b>RC-106*</b>	14,5	226	247	403	57
	203	<b>RC-108</b>	14,5	294	298	501	57
	257	<b>RC-1010*</b>	14,5	373	349	606	57
	304	<b>RC-1012</b>	14,5	441	400	704	57
	356	<b>RC-1014</b>	14,5	516	450	806	57
<b>15</b> (142)	25	<b>RC-151</b>	20,3	51	124	149	69
	51	<b>RC-152</b>	20,3	104	149	200	69
	101	<b>RC-154*</b>	20,3	205	200	301	69
	152	<b>RC-156*</b>	20,3	308	271	423	69
	203	<b>RC-158</b>	20,3	411	322	525	69
	254	<b>RC-1510</b>	20,3	516	373	627	69
	305	<b>RC-1512</b>	20,3	619	423	728	69
	356	<b>RC-1514</b>	20,3	723	474	830	69
<b>25</b> (232)	26	<b>RC-251</b>	33,2	86	139	165	85
	50	<b>RC-252*</b>	33,2	166	165	215	85
	102	<b>RC-254*</b>	33,2	339	215	317	85
	158	<b>RC-256*</b>	33,2	525	273	431	85
	210	<b>RC-258</b>	33,2	697	323	533	85
	261	<b>RC-2510</b>	33,2	867	374	635	85
	311	<b>RC-2512</b>	33,2	1033	425	736	85
	362	<b>RC-2514*</b>	33,2	1202	476	838	85
<b>30</b> (295)	209	<b>RC-308</b>	42,1	880	387	596	101
<b>50</b> (498)	51	<b>RC-502</b>	71,2	362	176	227	127
	101	<b>RC-504</b>	71,2	719	227	328	127
	159	<b>RC-506*</b>	71,2	1131	282	441	127
	337	<b>RC-5013</b>	71,2	2399	460	797	127
<b>75</b> (718)	156	<b>RC-756</b>	102,6	1601	285	441	146
	333	<b>RC-7513</b>	102,6	3417	492	825	146
<b>95</b> (933)	168	<b>RC-1006</b>	133,3	2239	357	525	177
	260	<b>RC-10010</b>	133,3	3466	449	709	177

\* Available as set, see note on this page.

\*\* RC-50 cylinder has a non removable grooved saddle and no collar thread.

\*\*\* D1 = 41 mm, L = 20 mm, M = 25 mm.



# Single-Acting, General Purpose Cylinders

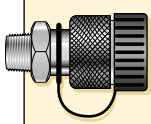

## Couplers Included!

CR-400 couplers included on all models. Fits all HC-Series hoses.

Capacity:  
**5 - 95 ton**

Stroke:  
**16 - 362 mm**

Maximum Operating Pressure:  
**700 bar**

## RC Series





Cylinder Bore Dia. E (mm)	Plunger Dia. F (mm)	Base to Adv. Port H (mm)	Saddle Dia. J (mm)	Saddle Protr. from Plgr. K (mm)	Plunger Internal Thread O	Plunger Thread Length P (mm)	Base Mounting Holes			Collar Thread W	Collar Thread Length X (mm)	 (kg)	Model Number
							Bolt Circle U (mm)	Thread V	Thd. Depth Z (mm)				
28,7	25,4	19	**	**	**	**	28	5,6 mm	—	—	—	1,0	RC-50**
28,7	25,4	19	25	6	3/4" - 16	14	25	1/4" - 20UN	14	1 1/2" - 16	28	1,0	RC-51
28,7	25,4	19	25	6	3/4" - 16	14	25	1/4" - 20UN	14	1 1/2" - 16	28	1,5	RC-53
28,7	25,4	19	25	6	3/4" - 16	14	25	1/4" - 20UN	14	1 1/2" - 16	28	1,9	RC-55*
28,7	25,4	19	25	6	3/4" - 16	16	25	1/4" - 20UN	14	1 1/2" - 16	28	2,4	RC-57
28,7	25,4	19	25	6	3/4" - 16	16	25	1/4" - 20UN	14	1 1/2" - 16	28	2,8	RC-59
42,9	38,1	19	—	—	#10 - 24UN	6	39	5/16" - 18UN	12	2 1/4" - 14	26	1,8	RC-101
42,9	38,1	19	35	6	1" - 8	19	39	5/16" - 18UN	12	2 1/4" - 14	26	2,3	RC-102*
42,9	38,1	19	35	6	1" - 8	19	39	5/16" - 18UN	12	2 1/4" - 14	26	3,3	RC-104
42,9	38,1	19	35	6	1" - 8	19	39	5/16" - 18UN	12	2 1/4" - 14	26	4,4	RC-106*
42,9	38,1	19	35	6	1" - 8	19	39	5/16" - 18UN	12	2 1/4" - 14	26	5,4	RC-108
42,9	38,1	19	35	6	1" - 8	19	39	5/16" - 18UN	12	2 1/4" - 14	26	6,4	RC-1010*
42,9	38,1	19	35	6	1" - 8	19	39	5/16" - 18UN	12	2 1/4" - 14	26	6,8	RC-1012
42,9	38,1	19	35	6	1" - 8	19	39	5/16" - 18UN	12	2 1/4" - 14	26	8,2	RC-1014
50,8	41,4	19	38	9	1" - 8	25	48	3/8" - 16UN	12	2 3/4" - 16	30	3,3	RC-151
50,8	41,4	19	38	9	1" - 8	25	48	3/8" - 16UN	12	2 3/4" - 16	30	4,1	RC-152
50,8	41,4	19	38	9	1" - 8	25	48	3/8" - 16UN	12	2 3/4" - 16	30	5,0	RC-154*
50,8	41,4	25	38	9	1" - 8	25	48	3/8" - 16UN	12	2 3/4" - 16	30	6,8	RC-156*
50,8	41,4	25	38	9	1" - 8	25	48	3/8" - 16UN	12	2 3/4" - 16	30	8,2	RC-158
50,8	41,4	25	38	9	1" - 8	25	48	3/8" - 16UN	12	2 3/4" - 16	30	9,5	RC-1510
50,8	41,4	25	38	9	1" - 8	25	48	3/8" - 16UN	12	2 3/4" - 16	30	10,9	RC-1512
50,8	41,4	25	38	9	1" - 8	25	48	3/8" - 16UN	12	2 3/4" - 16	30	11,8	RC-1514
65,0	57,2	25	50	10	1 1/2" - 16	19	58	1/2" - 13UN	19	3 5/16" - 12	49	5,9	RC-251
65,0	57,2	25	50	10	1 1/2" - 16	25	58	1/2" - 13UN	19	3 5/16" - 12	49	6,4	RC-252*
65,0	57,2	25	50	10	1 1/2" - 16	25	58	1/2" - 13UN	19	3 5/16" - 12	49	8,2	RC-254*
65,0	57,2	25	50	10	1 1/2" - 16	25	58	1/2" - 13UN	19	3 5/16" - 12	49	10,0	RC-256*
65,0	57,2	25	50	10	1 1/2" - 16	25	58	1/2" - 13UN	19	3 5/16" - 12	49	12,2	RC-258
65,0	57,2	25	50	10	1 1/2" - 16	25	58	1/2" - 13UN	19	3 5/16" - 12	49	14,1	RC-2510
65,0	57,2	25	50	10	1 1/2" - 16	25	58	1/2" - 13UN	19	3 5/16" - 12	49	16,3	RC-2512
65,0	57,2	25	50	10	1 1/2" - 16	25	58	1/2" - 13UN	19	3 5/16" - 12	49	17,7	RC-2514*
73,2	57,2	57	50	10	1 1/2" - 16	25	—	—	—	3 5/16" - 12	49	18,1	RC-308
95,2	79,5	33	71	2	—	—	95	1/2" - 13UN	19	5" - 12	55	15,0	RC-502
95,2	79,5	33	71	2	—	—	95	1/2" - 13UN	19	5" - 12	55	19,1	RC-504
95,2	79,5	35	71	2	—	—	95	1/2" - 13UN	19	5" - 12	55	23,1	RC-506*
95,2	79,5	35	71	2	—	—	95	1/2" - 13UN	19	5" - 12	55	37,6	RC-5013
114,3	95,2	30	71	5	—	—	—	—	—	5 3/4" - 12	44	29,5	RC-756
114,3	95,2	30	71	5	—	—	—	—	—	5 3/4" - 12	44	59,0	RC-7513
130,3	104,9	41	71	2	—	—	140	3/4" - 10UN	25	6 7/8" - 12	44	59,0	RC-1006
130,3	104,9	41	71	2	—	—	140	3/4" - 10UN	25	6 7/8" - 12	44	72,6	RC-10010

## ▼ SELECTION CHART

For use with Cylinder Capacity ton (kN)	Saddles			Base Plate	Mounting Block	Clevis Eyes	
	Flat	Grooved <sup>1)</sup>	Tilt			Base <sup>4)</sup>	Plunger
5 (45)	A-53F <sup>2)</sup>	A-53G <sup>2)</sup>	-	-	RB-5 <sup>2)</sup> , AW-51 <sup>2)</sup> , AW-53 <sup>2)</sup>	REB-5 <sup>2)</sup>	REP-5 <sup>2)</sup>
10 (101)	A-12 <sup>3)</sup> , A-102F <sup>3)</sup>	A-102G <sup>3)</sup>	CAT-10 <sup>3)</sup>	JB1-10	RB-10, AW-102	REB-10	REP-10 <sup>3)</sup>
15 (142)	-	A-152G	CAT-10	-	RB-15	REB-15	REP-10
25 (232)	A-29 <sup>5)</sup>	A-252G	CAT-50	JB1-25	RB-25	REB-25	REP-25
30 (295)	A-29 <sup>5)</sup>	A-252G	CAT-50	-	RB-25	-	REP-25
50 (498)	-	-	CAT-100	JB1-50	-	-	-
75 (718)	-	-	CAT-100	-	-	-	-
95 (933)	-	-	CAT-100	-	-	-	-

<sup>1)</sup> Standard on 5-30 ton RC-cylinders   <sup>2)</sup> Except RC-50   <sup>3)</sup> Except RC-101   <sup>4)</sup> Mounting screws are included.   <sup>5)</sup> Used with Bender Sets.

## ▼ DIMENSION CHARTS

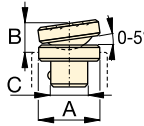
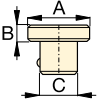
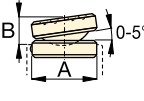
Model Nr.	Saddle Dimensions (mm)			A-53F, A-102F  A-12, A-29 	Model Nr.	Tilt Saddle Dimensions (mm)			
	A	B	C			A	B	C	
	<b>Flat</b>					<b>Tilt</b>			
A-53F	25	6	17		CAT-10	35	15	22	
A-102F	35	6	22		CAT-50	50	23	35	
A-12	51	48	1"-8UNC						
A-29	51	48	1 1/2"-16UNC						
	<b>Grooved</b>					<b>Tilt</b>			
A-53G	25	6	17		CAT-100	71	24	-	
A-102G	35	6	22						
A-152G	38	9	22						
A-252G	50	9	35						

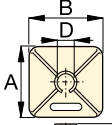
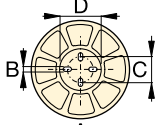
Model Nr.	Base Plate Dimensions (mm)						
	A	B	C	D	E		
JB1-10	228	228	135	58	20		
JB1-25	279	279	140	86	26		
JB1-50	304	15	95	131	31		

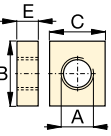
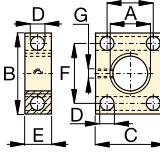
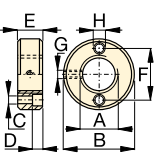
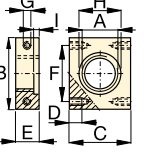
Model Nr.	Mounting Block Dimensions (mm)											
	A	B	C	D	E	F	G	H				
RB-5	1 1/2" - 16	88	76	-	25	-	-	-				
AW-51	1 1/2" - 16	70	59	10	24	54	1/4" - 20	41				
AW-53	1 1/2" - 16	72	7	7	19	57	1/4" - 20	10				
RB-10	2 1/4" - 14	114	88	-	25	-	-	-				
AW-102	2 1/4" - 14	100	82	16	30	76	7/16" - 20	58				
RB-15	2 3/4" - 16	101	114	-	38	-	-	-				
RB-25	3 5/16" - 12	127	165	-	50	-	-	-				

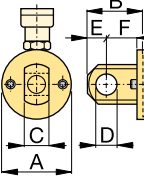
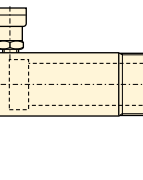
Type	Model Nr.	Clevis Eye Dimensions (mm)						Pin-to-Pin * (mm)		
		A	B	C	D	E	F			
Base <sup>4)</sup>	REB-5	44	47	14	16	16	25	60,2		
	REB-10	63	66	25	22	25	35	78,0		
	REB-15	76	66	25	22	25	35	78,0		
	REB-25	95	79	38	31	31	41	87,6		
Plunger	REP-5	28	41	14	16	16	19	-		
	REP-10	42	61	25	22	25	28	-		
	REP-25	57	74	38	31	31	35	-		

<sup>4)</sup> Mounting screws are included.

\* Pin to Pin- REB and REP Clevises fitted.  
Add cylinder stroke length.

# The Enerpac Lightweight Aluminium Cylinders

▼ From left to right: RAC, RACL, RACH, RAR



- Lightweight, easy to carry and position to allow a higher cylinder capacity-to-weight-ratio
- Non-corrosive by design, aluminium has always been a good material for use in many caustic environments
- Composite Bearings on all moving surfaces guarantee no metal-to-metal contact, to resist side loads and increase cylinder life.

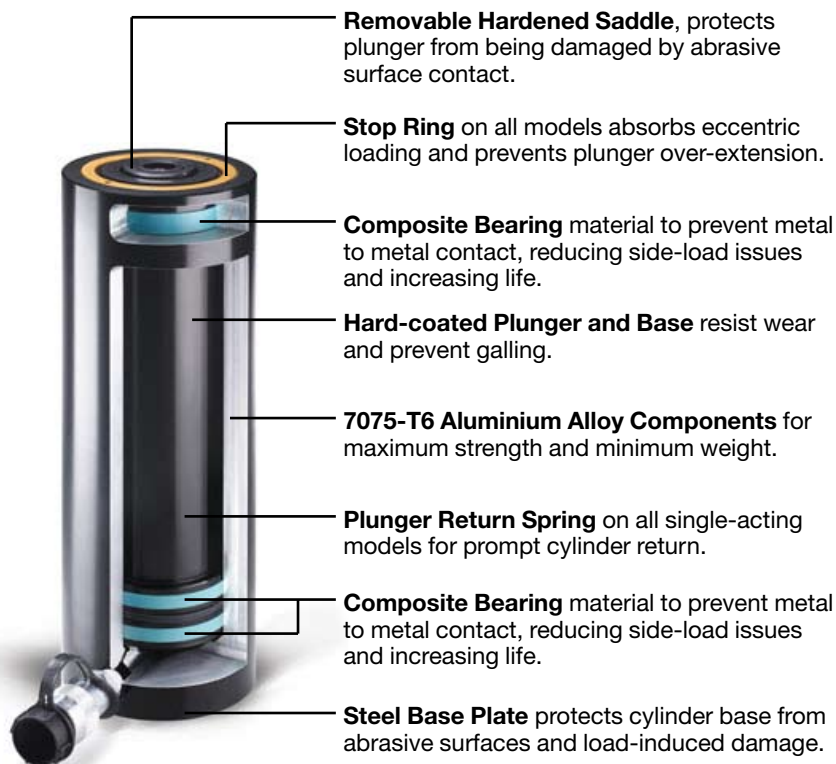

## RA Series

Capacity:  
**20 - 150 ton**

Stroke:  
**50 - 250 mm**

Maximum Operating Pressure:  
**700 bar**



**Think Safety**  
Manufacturer's rating of load and stroke are maximum safe limits.

Good practice encourages using only 80% of these ratings.

Page: 240



### RAC-Series, Single-Acting, Cylinders

The lightweight general purpose spring return aluminium cylinders.

Page: 12



### RACL-Series, Lock Nut, Cylinders

The lightweight spring return aluminium cylinders with lock nut for mechanical load holding.

Page: 14



### RACH-Series, Hollow Plunger Cylinders

For both push and pull forces with a single-acting cylinder.

Page: 16



### RAR-Series, Double-Acting Cylinders

The lightweight aluminium cylinders for lifting and lowering.

Page: 18



# RAC-Series, Aluminium Cylinders

▼ Shown from left to right: RAC-5010, RAC-15010, RAC-304, RAC-208



- Composite bearings prevent metal-to-metal contact, increasing cylinder life and resistance to side-loads of up to 10%
- Hard-Coat finish on all surfaces resists damage and extends cylinder life
- Handles included on all models
- Steel base plate and saddle for protection against load-induced damage
- Integral stop ring prevents plunger over-travel and is capable of withstanding the full cylinder capacity
- High strength return spring for rapid cylinder retraction
- CR-400 coupler and dustcap included on all models
- All cylinders meet ASME B-30.1 and ISO 10100 standards.



◀ The unique Enerpac RA-Series cylinders – lightweight and entirely made of aluminium alloy – these RAC-506 cylinders are ideal for the positioning of tunnel elements under the river. (High Speed Train Line, The Netherlands)

## Lightweight for Maximum Portability



### Saddles

All RAC-cylinders are equipped with bolt-on removable hardened steel saddles. For Tilt Saddles see next page.

Page: **13**



### Lightweight Hand Pumps

The Enerpac composite lightweight hand pumps P-392 or P-802 make the optimal lightweight set.

Page: **66**



### Lock Nut Cylinders

When positive mechanical load holding is required, RACL-Series Aluminium Lock Nut Cylinders are the ideal choice.

Page: **14**

### ▼ SELECTION CHART

Cylinder Capacity @ 700 bar ton (kN)	Stroke (mm)	Model Number *	Cylinder Effective Area (cm <sup>2</sup> )
20 (218)	50	RAC-202	31,2
	100	RAC-204	31,2
	150	RAC-206	31,2
30 (309)	50	RAC-302	44,2
	100	RAC-304	44,2
	150	RAC-306	44,2
50 (496)	50	RAC-502	70,9
	100	RAC-504	70,9
	150	RAC-506	70,9
100 (1002)	100	RAC-1004	143,1
	150	RAC-1006	143,1
	200	RAC-1008	143,1
150 (1589)	150	RAC-1506	227,0

\* Note: Every RAC-cylinder is available with a stroke of 50, 100, 150, 200 and 250 mm.

# Single-Acting, Aluminium Cylinders



## Aluminium versus Steel

Aluminium cylinders, while offering the most lightweight solution, also have some unique limitations due to material properties. It differs from steel in that it has a lower finite fatigue life. Aluminium cylinders should NOT be used in high-cycle applications such as production.

The Enerpac line of aluminium cylinders are designed to provide 5000 cycles at their recommended pressure. **This limit should not be exceeded.** In normal lifting and many maintenance applications, this should provide a lifetime of use.

## RAC Series



Capacity:

**20 - 150 ton**

Stroke:

**50 - 200 mm**

Maximum Operating Pressure:

**700 bar**

Optional Bolt-on Tilt Saddle Dimensions (mm)				
For Cylinder Model / Capacity ton	Tilt Saddle Model Number	Tilt Saddle Diameter J1	Saddle Protrusion from Plunger K1	
RAC-50	CATG-50	50	24	
RAC-100	CATG-150	91	31	
RAC-150	CATG-200	118	35	

Steel Base Plate Mounting Holes			
Cylinder Model / Capacity ton	Bolt Circle U (mm)	Thread V (mm)	Thread Depth <sup>1)</sup> Z (mm)
RAC-20	70	M6	12
RAC-30	80	M6	12
RAC-50	110	M6	12
RAC-100	160	M6	12
RAC-150	200	M6	12

<sup>1)</sup> Including Base Plate Height of 6 mm and four (4) base plate bolts M6.

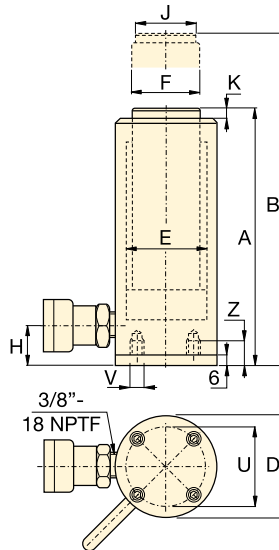

## Steel Base Plate

The steel base plate protects the cylinder from damage, it should not be removed.

The base holes in these aluminium cylinders are designed for securing the steel base plate. **They will not withstand the capacity of the cylinder.**

Do not use the base holes in these aluminium cylinders to attach any device to the cylinder.

Oil Capacity (cm <sup>3</sup> )	Collapsed Height A (mm)	Extended Height B (mm)	Outside Diameter D (mm)	Cylinder Bore Diameter E (mm)	Plunger Diameter F (mm)	Bottom to Advance Port H (mm)	Saddle Diameter J (mm)	Saddle Protrusion from Plunger K (mm)	Weight (kg)	Model Number *
156	174	224	85	63	50	27	40	3	3,6	RAC-202
312	224	324	85	63	50	27	40	3	4,1	RAC-204
468	274	424	85	63	50	27	40	3	4,6	RAC-206
221	181	231	100	75	60	32	40	3	4,5	RAC-302
442	231	331	100	75	60	32	40	3	5,2	RAC-304
663	281	431	100	75	60	32	40	3	5,9	RAC-306
354	186	236	130	95	80	30	50	3	8,5	RAC-502
709	236	336	130	95	80	30	50	3	9,8	RAC-504
1063	286	436	130	95	80	30	50	3	11,1	RAC-506
1431	271	271	180	135	110	46	94	3	19,6	RAC-1004
2147	321	471	180	135	110	46	94	3	21,9	RAC-1006
2863	371	571	180	135	110	46	94	3	24,2	RAC-1008
3405	343	493	230	170	140	51	113	3	33,3	RAC-1506

▼ Shown from left to right: RACL-1006, RACL-504, RACL-5010



- Aluminium Lock Nut provides mechanical load holding for extended periods
- Hardened steel stop ring increasing cylinder life and resistance to side-loads of up to 5%
- Hard-Coat finish on all surfaces resists damage and extends cylinder life
- Composite bearings increase cylinder life and side load resistance
- Handles included on all models
- Steel base plate and saddle for protection against load-induced damage
- Integral stop ring prevents plunger over-travel and is capable of withstanding the full cylinder capacity
- High strength return spring for rapid cylinder retraction
- CR-400 coupler and dustcap included on all models
- All cylinders meet ASME B-30.1 and ISO 10100 standards.



◀ The portable lock nut cylinder RACL-1506 used for extended load supports during epoxy injection for bridge reinforcement.

## To Secure Loads Mechanically



### Saddles

All RACL-cylinders are equipped with bolt-on removable hardened steel saddles. For Tilt Saddles

see next page.

Page: 15



### Hoses

Enerpac offers a complete line of high quality hydraulic hoses. To ensure the integrity of your system,

specify only Enerpac hydraulic hoses.

Page: 120



### Gauges

Minimize the risk of overloading and ensure long, dependable service from your equipment. Refer

to the System Components Section for a full range of gauges.

Page: 118

### ▼ SELECTION CHART

Cylinder Capacity @ 700 bar ton (kN)	Stroke (mm)	Model Number *	Cylinder Effective Area (cm <sup>2</sup> )
30 (309)	50	RACL-302	44,2
	100	RACL-304	44,2
	150	RACL-306	44,2
50 (496)	50	RACL-502	70,9
	100	RACL-504	70,9
	150	RACL-506	70,9
100 (1002)	50	RACL-1002	143,1
	100	RACL-1004	143,1
	150	RACL-1006	143,1
150 (1589)	50	RACL-1502	227,0
	100	RACL-1504	227,0
	150	RACL-1506	227,0

\* Note: Every RACL-cylinder is available with a stroke of 50, 100, 150, 200 and 250 mm.



# Single-Acting, Aluminium Lock Nut Cylinders



## Aluminium versus Steel

Aluminium cylinders, while offering the most lightweight solution, also have some unique limitations due to material properties. It differs from steel in that it has a lower finite fatigue life. Aluminium cylinders should NOT be used in high-cycle applications such as production.

The Enerpac line of aluminium cylinders are designed to provide 5000 cycles at their recommended pressure. **This limit should not be exceeded.** In normal lifting and many maintenance applications, this should provide a lifetime of use.

## RACL Series

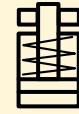

Capacity:

**30 - 150 ton**

Stroke:

**50 - 150 mm**

Maximum Operating Pressure:

**700 bar**

Optional Bolt-on Tilt Saddle Dimensions (mm)				
For Cylinder Model / Capacity ton	Tilt Saddle Model Number	Tilt Saddle Diameter J1	Saddle Protrusion from Plunger K1	
RACL-50	CATG-50	50	24	
RACL-100	CATG-150	91	31	
RACL-150	CATG-200	118	35	

Steel Base Plate Mounting Holes			
Cylinder Model / Capacity ton	Bolt Circle U (mm)	Thread V (mm)	Thread Depth <sup>1)</sup> Z (mm)
RACL-30	80	M6	12
RACL-50	110	M6	12
RACL-100	160	M6	12
RACL-150	200	M6	12

<sup>1)</sup> Including Base Plate Height of 6 mm and four (4) base plate bolts M6.

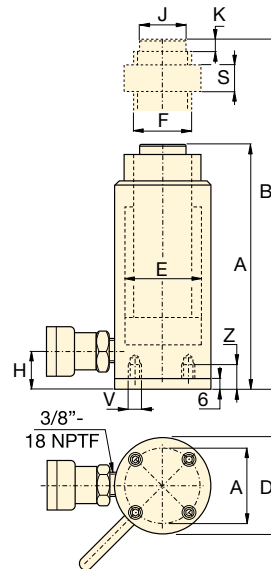

### Steel Base Plate

The steel base plate protects the cylinder from damage, it should not be removed.

The base holes in these aluminium cylinders are designed for securing the steel base plate. **They will not withstand the capacity of the cylinder.** Do not use the base holes in these aluminium cylinders to attach any device to the cylinder.



### Lifting an Unbalanced Load ?

When lifting an unbalanced load Enerpac synchronous Lifting Systems can be the solution with multiple lift point capabilities from 4 to 64 points.

Page: **224**

Oil Capacity (cm <sup>3</sup> )	Collapsed Height A (mm)	Extended Height B (mm)	Outside Diameter D (mm)	Cylinder Bore Diameter E (mm)	Plunger Diameter (Threaded) F (mm)	Bottom to Advance Port H (mm)	Saddle Diameter J (mm)	Saddle Protrusion fr. Plunger K (mm)	Lock Nut Height S (mm)	Lock Nut (kg)	Model Number *
221	231	281	100	75	Tr 60 x 4	33	40	3	50	5,4	RACL-302
442	218	381	100	75	Tr 60 x 4	33	40	3	50	6,1	RACL-304
663	331	481	100	75	Tr 60 x 4	33	40	3	50	6,8	RACL-306
354	236	286	130	95	Tr 80 x 4	30	50	3	50	9,3	RACL-502
709	286	386	130	95	Tr 80 x 4	30	50	3	50	10,6	RACL-504
1063	336	486	130	95	Tr 80 x 4	30	50	3	50	11,9	RACL-506
716	296	346	180	135	Tr 110 x 6	46	94	3	75	21,9	RACL-1002
1431	346	446	180	135	Tr 110 x 6	46	94	3	75	24,2	RACL-1004
2147	396	546	180	135	Tr 110 x 6	46	94	3	75	26,5	RACL-1006
1135	323	373	230	170	Tr 140 x 6	51	113	3	80	32,2	RACL-1502
2270	373	473	230	170	Tr 140 x 6	51	113	3	80	36,2	RACL-1504
3405	423	573	230	170	Tr 140 x 6	51	113	3	80	40,2	RACL-1506

▼ Shown from left to right: RACH-1504, RACH-15010, RACH-206, RACH-306



- Hollow plunger design allows for both pull and push forces
- Composite bearings increase cylinder life and sideload resistance
- Hard-Coat finish on all surfaces resists damage and extends cylinder life
- Floating center tube increases seal and product life
- Handles standard on all models
- Steel base plate and saddle for protection against load-induced damage
- Integral stop ring prevents plunger over-travel and is capable of withstanding the full cylinder capacity
- High strength return spring for rapid cylinder retraction.



◀ An RACH-306 powered by a P-392 hand pump used to extract corroded carriage pins of refuse collection vehicles.

## The Lightweight Solution for Tensioning and Testing



### Saddles

All RACH-cylinders are equipped with bolt-on hollow removable saddles of hardened steel.



### Lightweight Hand Pumps

The Enerpac composite lightweight hand pumps P-392 or P-802 make the optimal lightweight set.

Page: 66



### Hoses

Enerpac offers a complete line of high quality hydraulic hoses. To ensure the integrity of your system,

specify only Enerpac hydraulic hoses.

Page: 120

### ▼ SELECTION CHART

Cylinder Capacity @ 700 bar ton (kN)	Stroke (mm)	Model Number *	Cylinder Effective Area (cm <sup>2</sup> )
20 (229)	50	RACH-202	32,7
	150	RACH-206	32,7
30 (358)	50	RACH-302	51,1
	150	RACH-306	51,1
60 (596)	100	RACH-604	84,7
	150	RACH-606	84,7
100 (1157)	150	RACH-1006	164,6

\* Note: Every RACH-cylinder is available with a stroke of 50, 100, 150, 200 and 250 mm.

# Single-Acting, Aluminium Hollow Plunger Cylinders



## Aluminium versus Steel

Aluminium cylinders, while offering the most lightweight solution, also have some unique limitations due to material properties. It differs from steel in that it has a lower finite fatigue life. Aluminium cylinders should NOT be used in high-cycle applications such as production.

The Enerpac line of aluminium cylinders are designed to provide 5000 cycles at their recommended pressure. **This limit should not be exceeded.** In normal lifting and many maintenance applications, this should provide a lifetime of use.

## RACH Series

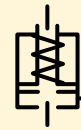

Capacity:  
**20 - 100 ton**

Stroke:  
**50 - 150 mm**

Center Hole Diameter:  
**27 - 79 mm**

Maximum Operating Pressure:  
**700 bar**

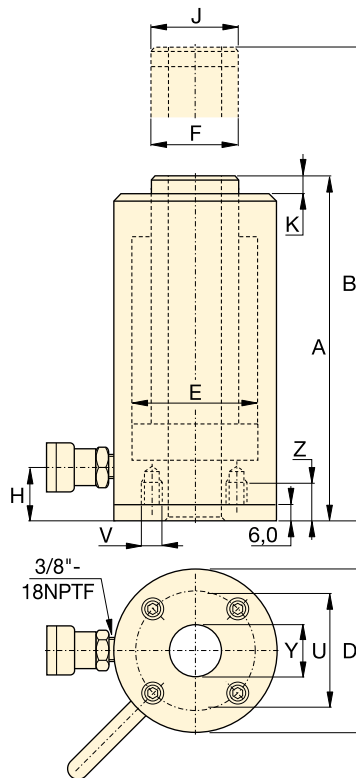

### Steel Base Plate

The steel base plate protects the cylinder from damage, it should not be removed.

The base holes in these aluminium cylinders are designed for securing the steel base plate. **They will not withstand the capacity of the cylinder.**

Do not use the base holes in these aluminium cylinders to attach any device to the cylinder.

Steel Base Plate Mounting Holes

Cylinder Model / Capacity ton	Bolt Circle U (mm)	Thread V (mm)	Thread Depth <sup>1)</sup> Z (mm)
RACH-20	80	M6	12
RACH-30	110	M6	12
RACH-60	160	M6	12
RACH-100	230	M6	12

<sup>1)</sup> Including Base Plate Height of 6 mm and four (4) base plate bolts M6.



### Standard Features

- CR-400 coupler and dustcap included on all models.
- All cylinders meet ASME B-30.1 and ISO 10100 standards.

Oil Capacity (cm <sup>3</sup> )	Collapsed Height A (mm)	Extended Height B (mm)	Outside Diameter D (mm)	Cylinder Bore Diameter E (mm)	Plunger Diameter F (mm)	Bottom to Adv. Port H (mm)	Saddle Diameter J (mm)	Saddle Protrusion from Plunger K (mm)	Center Hole Diameter Y (mm)	Model Number *
164	188	238	100	75	55	29	55	10	27	RACH-202
491	315	465	100	75	55	29	55	10	27	RACH-206
256	208	258	130	95	70	29	70	10	34	RACH-302
766	333	483	130	95	70	29	70	10	34	RACH-306
847	315	415	180	130	100	61	100	12	54	RACH-604
1270	380	530	180	130	100	61	100	12	54	RACH-606
2487	391	541	250	185	145	61	145	14	79	RACH-1006



▼ Shown from left to right: RAR-5010, RAR-308, RAR-204



- Double-acting for rapid retraction, regardless of hose lengths or system losses
- Composite bearings increase cylinder life and sideload resistance
- Hard-Coat finish on all surfaces resists damage and extends cylinder life
- Handles included on all models
- Steel base plate and saddle for protection against load-induced damage
- Integral stop ring prevents plunger over-travel and is capable of withstanding the full cylinder capacity
- Built-in safety valve prevents accidental over-pressurization.

## The Lightweight Solution for Tensioning and Testing



### Saddles

All RAR-cylinders are equipped with bolt-on removable hardened steel saddles.

For Tilt Saddles see next page.

Page: 19



### Hoses

Enerpac offers a complete line of high quality hydraulic hoses. To ensure the integrity of your system, specify only Enerpac hydraulic hoses.

Page: 120



### Optimum Performance

Enerpac's range of Z-Class electric pumps, fitted with manual or solenoid operated 4-way valves, offer optimum combinations with RAR cylinders.

Page: 84

▼ An RAR-506 was easy to position under a bulldozer for repair of frame member.



### ▼ SELECTION CHART

Cylinder Capacity @ 700 bar ton	Stroke (mm)	Model Number *	Maximum Cylinder Capacity (kN)		Cylinder Effective Area (cm <sup>2</sup> )		Oil Capacity (cm <sup>3</sup> )	
			Push	Pull	Push	Pull	Push	Pull
50	50	RAR-502	496	187	70,9	26,7	354	134
	100	RAR-504	496	187	70,9	26,7	709	267
	150	RAR-506	496	187	70,9	26,7	1063	401
100	100	RAR-1004	1002	557	143,1	79,5	1431	795
	150	RAR-1006	1002	557	143,1	79,5	2147	1193
	200	RAR-1008	1002	557	143,1	79,5	2863	1590
150	150	RAR-1506	1589	924	227,0	132,0	3405	1980

\* Note: Every RAR-cylinder is available with a stroke of 50, 100, 150, 200 and 250 mm.

# Double-Acting, Aluminium Cylinders



## Aluminium versus Steel

Aluminium cylinders, while offering the most lightweight solution, also have some unique limitations due to material properties. It differs from steel in that it has a lower finite fatigue life. Aluminium cylinders should NOT be used in high-cycle applications such as production.

The Enerpac line of aluminium cylinders are designed to provide 5000 cycles at their recommended pressure. **This limit should not be exceeded.** In normal lifting and many maintenance applications, this should provide a lifetime of use.

## RAR Series



Capacity:  
**50 - 150 ton**

Stroke:  
**50 - 200 mm**

Maximum Operating Pressure:  
**700 bar**

Optional Bolt-on Tilt Saddle Dimensions (mm)				
For Cylinder Model / Capacity ton	Tilt Saddle Model Number	Tilt Saddle Diameter J1	Saddle Protrusion from Plunger K1	
RAR-50	CATG-50	50	24	
RAR-100	CATG-150	91	31	
RAR-150	CATG-200	118	35	

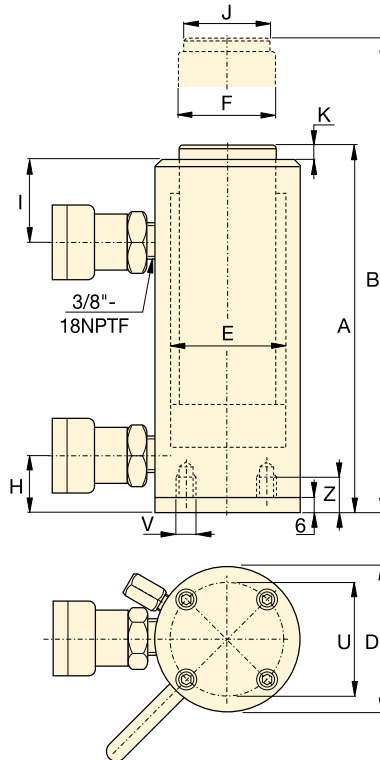

Steel Base Plate Mounting Holes			
Cylinder Model / Capacity ton	Bolt Circle U (mm)	Thread V (mm)	Thread Depth <sup>1)</sup> Z (mm)
RAR-50	110	M6	12
RAR-100	165	M6	12
RAR-150	200	M6	12

<sup>1)</sup> Including Base Plate Height of 6 mm and four (4) base plate bolts M6.



### Steel Base Plate

The steel base plate protects the cylinder from damage, it should not be removed.

The base holes in these aluminium cylinders are designed for securing the steel base plate. **They will not withstand the capacity of the cylinder.**

Do not use the base holes in these aluminium cylinders to attach any device to the cylinder.



### Standard Features

- CR-400 coupler and dustcap included on all models.
- All cylinders meet ASME B-30.1 and ISO 10100 standards.

Collapsed Height A (mm)	Extended Height B (mm)	Outside Diameter D (mm)	Cylinder Bore Diameter E (mm)	Plunger Diameter F (mm)	Bottom to Advance Port H (mm)	Top to Retract Port I (mm)	Saddle Diameter J (mm)	Saddle Protrusion from Plunger K (mm)	(kg)	Model Number *
201	251	145	95	75	30	56	50	3	11,1	RAR-502
251	351	145	95	75	30	56	50	3	12,7	RAR-504
301	451	145	95	75	30	56	50	3	14,3	RAR-506
301	401	185	135	90	43	80	94	3	19,3	RAR-1004
351	501	185	135	90	43	80	94	3	22,2	RAR-1006
401	601	185	135	90	43	80	94	3	25,1	RAR-1008
348	498	230	170	110	38	75	113	3	33,2	RAR-1506

▼ Shown from left to right: CLP-2002, CLP-5002



- Extremely low height for use in confined areas
- Lock nut for positive and safe mechanical load holding over a long period of time
- Single-acting, load return
- Optional special synthetic coating for improved corrosion resistance and lower friction for smoother operation
- Overflow port functions as a stroke limiter
- CR-400 coupler and dust cap included on all models.

▼ Only the extreme low height CLP-cylinder fits in this confined area to lift the construction. The V-82 needle valve is used to control cylinder speed during lifting and lowering.



## The Shortest Power Lifter



### Tilt Saddles

All CLP-Series cylinders include integral tilt saddles with maximum tilt angles up to 5°.



### Gauges

Minimize the risk of overloading and ensure long, dependable service from your equipment. Refer to the

System Components Section for a full range of gauges.

Page: **118**



### Hoses

Enerpac offers a complete line of high quality hydraulic hoses. To ensure the integrity of your system, specify only Enerpac hydraulic hoses.

Page: **120**

Cylinder Capacity	Stroke	Model Number*	Cylinder Effective Area	Oil Capacity
ton (kN)	(mm)		(cm <sup>2</sup> )	(cm <sup>3</sup> )
<b>60</b> (606)	50	<b>CLP-602</b>	86,6	432
<b>100</b> (1027)	50	<b>CLP-1002</b>	146,8	734
<b>160</b> (1619)	45	<b>CLP-1602</b>	231,3	1040
<b>200</b> (1999)	45	<b>CLP-2002</b>	285,6	1285
<b>260</b> (2567)	45	<b>CLP-2502</b>	366,8	1650
<b>400</b> (3916)	45	<b>CLP-4002</b>	559,5	2517
<b>520</b> (5114)	45	<b>CLP-5002</b>	730,6	3287

\* Please contact Enerpac for ordering information for CLP-cylinders with special synthetic coating.



# Single-Acting, Pancake Lock Nut Cylinders



## Speed Chart

See the Enerpac Cylinder Speed Chart in our 'Yellow Pages' to determine your approximate cylinder speed.

Page: 249



## Longer Stroke Lock Nut Cylinders

For longer stroke lock nut applications **CLL-Series** cylinders are the perfect choice.

Page: 48

## CLP Series



Capacity:

**60 - 520 ton**

Stroke:

**45 - 50 mm**

Maximum Operating Pressure:

**700 bar**

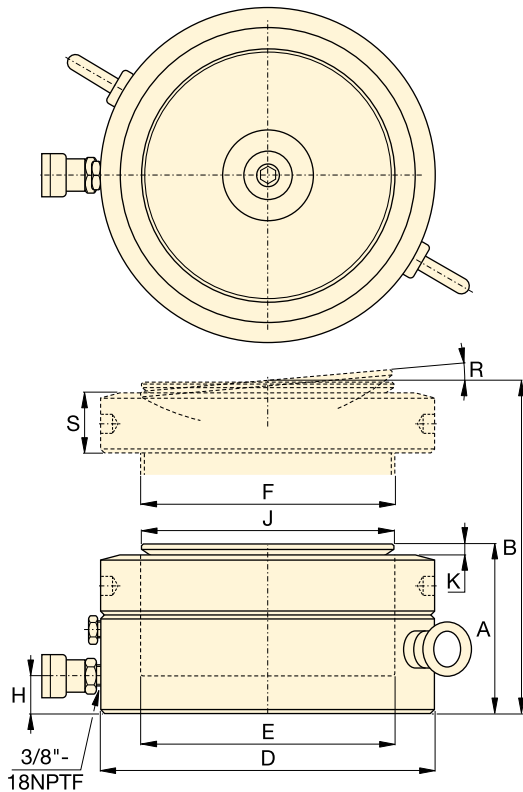

**ALL CLP-SERIES CYLINDERS REQUIRE A SOLID LIFTING SURFACE FOR CORRECT SUPPORT.**

**USE OF PANCAKE CYLINDERS ON SURFACES SUCH AS SAND, MUD OR DIRT, MAY RESULT IN CYLINDER DAMAGE!**

**WRONG!**

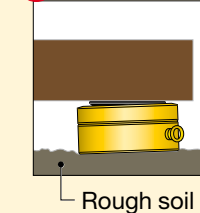

Rough soil

**RIGHT!**

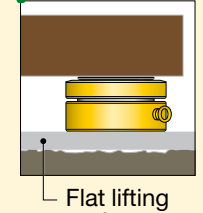

Flat lifting surface

For more safety instructions see our 'Yellow Pages'.

Page: 240

Collapsed Height	Extended Height	Outside Diameter	Cylinder Bore Diameter	Plunger Diameter	Base to Advance Port	Saddle Diameter	Saddle Protrusion from Plgr.	Saddle Max. Tilt Angle	Lock Nut Height	(kg)	Model Number*
A (mm)	B (mm)	D (mm)	E (mm)	F (mm)	H (mm)	J (mm)	K (mm)	R	S (mm)		
125	175	140	105,0	Tr 104 x 4	19	96	6	5°	28	15	CLP-602
137	187	175	136,7	Tr 136 x 6	21	126	8	5°	31	26	CLP-1002
148	193	220	171,6	Tr 171 x 6	27	160	9	5°	40	44	CLP-1602
155	200	245	190,7	Tr 190 x 6	30	180	10	5°	43	57	CLP-2002
159	204	275	216,1	Tr 216 x 6	32	200	11	5°	44	74	CLP-2502
178	223	350	266,9	Tr 266 x 6	39	250	11	4°	55	134	CLP-4002
192	237	400	305,0	Tr 305 x 6	48	290	10	3°	62	189	CLP-5002

▼ Shown from left to right: RSM-1000, RSM-300, RSM-50, RCS-1002, RCS-302



## Maximum Power-to-Height Ratio



### Saddles

All RCS-Series cylinders have plunger mounting holes for installation of tilt saddles. See table for selection and dimensional information.

Page: **23**



### Low Clearance Lifting

The LW-16 Lifting Wedge and SOH-Series Machine Lifts are the perfect choice for lifting the first few millimeters.

Page: **172**

### RSM-series, Flat-Jac® Cylinders

- Compact, flat design for use where most other cylinders will not fit
- Single-acting, spring return
- RSM-750, 1000 and 1500 have handles for easy carrying
- Mounting holes permit easy fixturing
- Baked enamel finish for increased corrosion resistance
- CR-400 coupler and dust cap included on all models<sup>1)</sup>
- Hard chrome plated high quality steel plungers
- Grooved plunger ends require no saddle.

### RCS-series, Low Height Cylinders

- Lightweight, low profile design for use in confined spaces
- Single-acting, spring return
- Baked enamel finish for increased corrosion resistance
- Plunger wiper reduces contamination, extending cylinder life
- CR-400 coupler and dust cap included on all models
- Grooved plunger end with threaded holes for mounting tilt saddles
- Integral handle on RCS-1002 for easy carrying
- Plated steel plungers.

▼ Only a couple of centimeters will do for an RSM-cylinder to lift a large construction.



Cyl. Capacity ton (kN)	Stroke (mm)	Model Number	Cyl. Effect. Area (cm <sup>2</sup> )	Oil Cap. (cm <sup>3</sup> )
5 (45)	6	RSM-50 <sup>1)</sup>	6,5	4
10 (101)	12	RSM-100	14,5	18
20 (201)	11	RSM-200	28,7	32
30 (295)	13	RSM-300	42,1	55
45 (435)	16	RSM-500	62,1	99
75 (718)	16	RSM-750	102,6	164
90 (887)	16	RSM-1000	126,7	203
150 (1386)	16	RSM-1500	198,1	317
10 (101)	38	RCS-101*	14,5	55
20 (201)	45	RCS-201*	28,7	129
30 (295)	62	RCS-302*	42,1	261
45 (435)	60	RCS-502*	62,1	373
90 (887)	57	RCS-1002*	126,7	722

<sup>1)</sup> RSM-50 is fitted with an AR-400 coupler. Available as set, see note on next page.

# Single-Acting, Low Height Cylinders

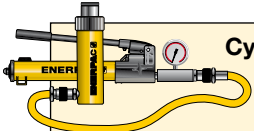

## Cylinder-Pump Sets

All cylinders marked with an \* are available as sets (cylinder, gauge, couplers, hose and pump) for your ordering convenience.

Page: **62**

## RSM, RCS Series



Capacity:

**5 - 150 ton**

Stroke:

**6 - 62 mm**

Maximum Operating Pressure:

**700 bar**

### Optional Bolt On Tilt Saddle Dimensions (mm)

For Cylinder Model:	Model Number	A	B	C*
RCS-101	CAT-11	35	11	21
RCS-201, -302, -502	CAT-51	50	15	29
RCS-1002	CAT-101	71	17	35

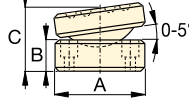

\* 'C' dimension equals saddle protrusion from plunger. Mounting screws are included.

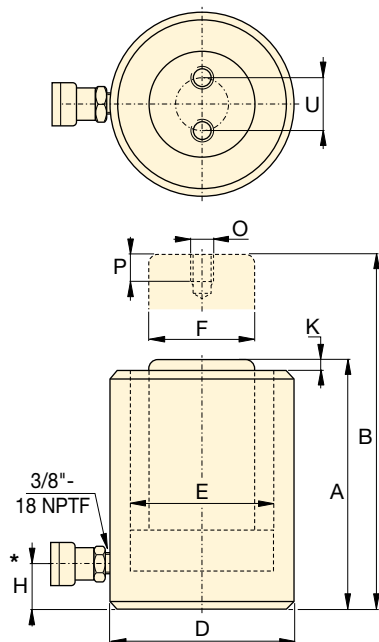

**RCS-Series**

\* 5° angle position of coupler on RCS-101, 201,302

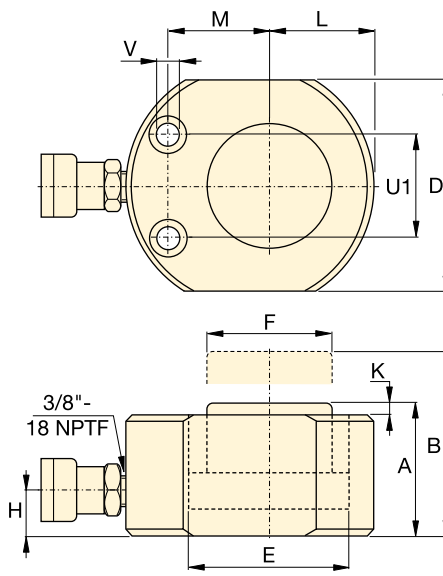

**RSM-Series**

### RSM Cylinder Mounting Hole Dimensions (mm)

Model Number	Bolt Circle U1	Hole Dia. V	Counter Bore Dia.	Counter Bore Depth
RSM-50	28,5	5,5	9,1	4,3
RSM-100	36,6	7,1	10,7	7,9
RSM-200	49,3	10,0	15,1	9,9
RSM-300	52,3	10,0	15,9	11,2
RSM-500	66,5	11,0	19,0	12,7
RSM-750	76,2	13,5	20,6	14,2
RSM-1000	76,2	13,5	20,6	14,2
RSM-1500	117,3	13,5	20,6	14,2

Collapsed Height	Extended Height	Outside Diameter	Cylinder Bore Dia.	Plunger Dia.	Base to Advance Port	Plunger Protrusion from Base	Plunger to Base	Plunger to Mtg. Hole	Thread	Thread Depth	Bolt Circle	Weight	Model Number
A (mm)	B (mm)	D (mm)	E (mm)	F (mm)	H (mm)	K (mm)	L (mm)	M (mm)	O (mm)	P (mm)	U (mm)	(kg)	
32	38	58 x 41	28,7	25,4	16	1	20	22	-	-	-	1,0	RSM-50 <sup>1)</sup>
43	54	82 x 55	42,9	38,1	19	1	27	34	-	-	-	1,4	RSM-100
51	62	101 x 76	60,5	50,8	19	1	39	39	-	-	-	3,1	RSM-200
58	71	117 x 95	73,2	63,4	19	2	47	44	-	-	-	4,5	RSM-300
66	82	140 x 114	88,9	69,8	19	2	57	53	-	-	-	6,8	RSM-500
79	95	165 x 139	114,3	82,6	19	2	69	66	-	-	-	11,3	RSM-750
85	101	178 x 153	127,0	92,2	19	2	76	74	-	-	-	14,5	RSM-1000
100	116	215 x 190	158,8	114,3	23	2	95	82	-	-	-	26,3	RSM-1500
88	126	69	42,9	38,1	17	5	-	-	M4	8	26	4,1	RCS-101*
98	143	92	60,5	50,8	17	3	-	-	M5	8	40	5,0	RCS-201*
117	179	101	73,2	66,5	19	3	-	-	M5	8	40	6,8	RCS-302*
122	182	124	88,9	69,8	23	2	-	-	M5	8	40	10,9	RCS-502*
141	198	165	127,0	92,2	31	1	-	-	M8	10	55	22,7	RCS-1002*



# BRC, BRP-Series, Pull Cylinders

▼ Shown from left to right: BRC-25, BRC-46, BRP-306, BRP-606, BRP-106C



- High strength alloy steel construction
- Plunger blow-out protection to prevent rod over-extension
- Hard chrome-plated plunger for long life
- Replaceable links on BRP-models
- Baked enamel finish for increased corrosion resistance
- CR-400 coupler and dust cap included on all models
- Plunger wiper reduces contamination, extending cylinder life
- Single-acting, spring return.

▼ Ship building, welding and Enerpac pull cylinders go hand in hand.



## The Ultimate in Pulling Power

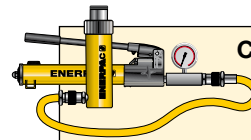

### Cylinder-Pump Sets

All cylinders marked with an \* are available as sets (cylinder, gauge, couplers, hose and pump) for your ordering convenience.

Page: 62



### Gauges

Minimize the risk of overloading and ensure long, dependable service from your equipment. Refer to the System Components Section for a full range of gauges.

Page: 118



### Attachments and Accessories

BRC-25 and BRC-46 units have base, collar and plunger threads to affix a range of optional attachments and accessories, such as chains, saddles and extension tubes.

Page: 165

▼ To lift a load bearing mast into place, BRP-series cylinders were used to tension the supporting cables.



# Single-Acting, Pull Cylinders

BRC Cylinder Mounting Dimensions (mm)				
Model Number	Base Mounting Hole V	Collar Thread W	Collar Thd. Lgth. X	Mtg. Thd. Lgth. Z
<b>BRC-25</b>	3/4" - 14 NPT	1 1/2" - 16 UN	24	17
<b>BRC-46</b>	1 1/4" - 11 1/2 NPT	2 1/4" - 14 UN	26	24
<b>BRC-106</b>	M30 x 2	M85 x 2	25	24

**BRC,  
BRP  
Series**



Capacity:

**2,5 - 50 ton**

Stroke:

**127 - 155 mm**

Maximum Operating Pressure:

**700 bar**

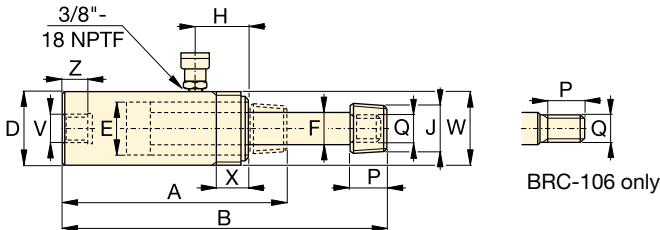

**BRC-25, -46, 106**

Cylinder Capacity	Stroke	Model Number	Cyl. Effect. Area	Oil Cap.	Coll. Height	Ext. Height	Outs. Dia.	Cyl. Bore Dia.	Plgr. Dia.	Top to Inlet Port H	Saddle Diameter	Plgr. Thd. Lgth. P	Plunger Outside Thread Q	
ton (kN)	(mm)		(cm <sup>2</sup> )	(cm <sup>3</sup> )	A (mm)	B (mm)	D (mm)	E (mm)	F (mm)	(mm)	J (NPT)	(mm)	(mm)	(kg)
<b>2,5 (24)</b>	127	<b>BRC-25</b>	3,5	45	264	391	48	28,4	19,0	45	3/4" - 14	28	1 1/16" - 24	1,8
<b>5 (51)</b>	140	<b>BRC-46</b>	7,3	101	301	441	57	42,9	30,2	42	1 1/4" - 11 1/2	32	1 3/16" - 16	4,5
<b>10 (105)</b>	151	<b>BRC-106</b>	15,0	228	289	440	85	54,1	31,8	39	-	25	M30x2	9,5

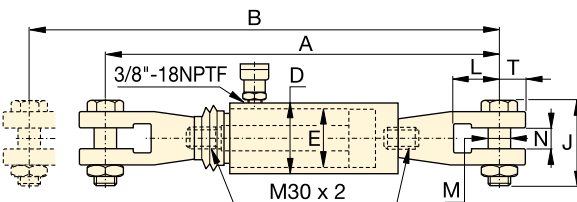

**BRP-106C**

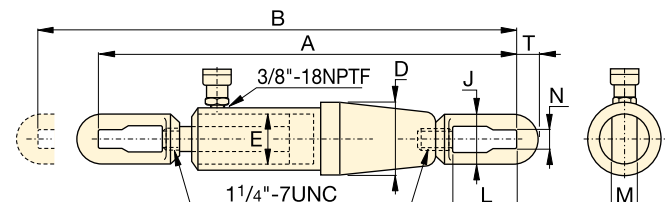

**BRP-306**

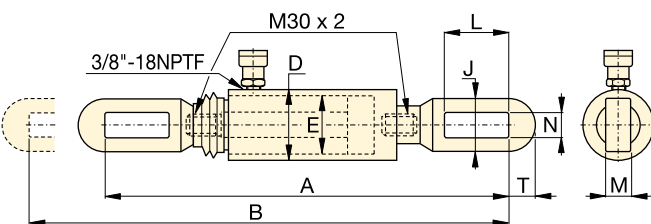

**BRP-106L**

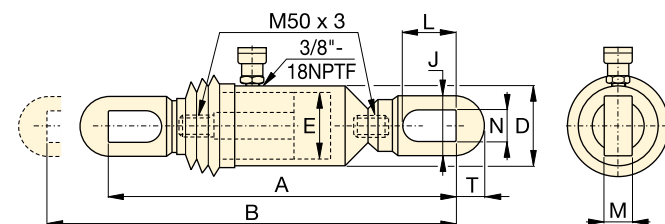

**BRP-606**

Cylinder Capacity	Stroke	Model Number	Cyl. Effect. Area	Oil Cap.	Coll. Height	Ext. Height	Outside Dia.	Cyl. Bore Dia.	Link Height	Link Opening L	Link Thickness M	Link Width N	Slot to Link End T	
ton (kN)	(mm)		(cm <sup>2</sup> )	(cm <sup>3</sup> )	A (mm)	B (mm)	D (mm)	E (mm)	J (mm)	(mm)	(mm)	(mm)	(mm)	(kg)
<b>10 (105)</b>	151	<b>BRP-106C*</b>	15,0	227	587	738	85	54,1	119	62	30	35	32	15,9
	151	<b>BRP-106L*</b>	15,0	227	541	692	85	54,1	67	115	22	30	32	13,2
<b>30 (326)</b>	155	<b>BRP-306*</b>	46,6	722	1085	1240	136	88,9	114	145	35	39	50	48,1
<b>50 (505)</b>	152	<b>BRP-606*</b>	72,1	1096	719	871	140	110,0	130	149	39	50	70	53,5

\* Available as set, see note on previous page. NOTE: BRP-106C, BRP-106L and BRP-606 are fitted with rubber bellows for rod protection.

# RCH-Series, Hollow Plunger Cylinders

▼ Shown from left to right: RCH-306, RCH-120, RCH-1003



- Hollow plunger design allows for both, pull and push forces
- Single-acting, spring return
- Nickel-plated, floating center tube on models over 20 ton increases product life
- Baked enamel finish for increased corrosion resistance
- Collar threads for easy fixturing
- RCH-120 includes AR-630 coupler and has 1/4" NPTF port
- RCH-121 and RCH-1211 have FZ-1630 reducer and AR-630 coupler, all other models feature CR-400 coupler.

▼ Hollowplunger cylinder RCH-1003 used in an application for intermediate boom suspension on a dragline.



## Versatility in Testing, Maintenance and Tensioning Applications

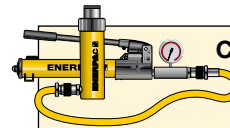

### Cylinder-Pump Sets

All cylinders marked with an \* are available as sets (cylinder, gauge, couplers, hose and pump) for your ordering convenience.

Page: 62



### Ultra-Lightweight Aluminium Cylinders

If you need a higher cylinder capacity-to-weight-ratio the lightweight RACH-Series are the perfect choice.

Page: 16



### Saddles

Most RCH-Series cylinders are equipped with smooth saddles. See table at next page for optional threaded saddles and all dimensional information.

Page: 27

Cylinder Capacity	Stroke	Model Number	Cyl. Effect. Area	Oil Cap.
ton (kN)	(mm)		(cm <sup>2</sup> )	(cm <sup>3</sup> )
13 (125)	8	RCH-120	17,9	14
	42	RCH-121*	17,9	75
	42	RCH-1211	17,9	75
	76	RCH-123	17,9	136
20 (215)	49	RCH-202*	30,7	150
	155	RCH-206	30,7	476
30 (326)	64	RCH-302*	46,6	298
	155	RCH-306	46,6	722
60 (576)	76	RCH-603*	82,3	626
	153	RCH-606	82,3	1259
95 (931)	76	RCH-1003*	133,0	1011

\* Available as set, see note on this page.



# Single-Acting, Hollow Plunger Cylinders



## Hoses

Enerpac offers a complete line of high quality hydraulic hoses. To ensure the integrity of your system, specify only Enerpac hydraulic hoses.

Page: **120**

## RCH Series

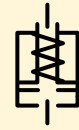

Capacity:

**13-95 ton**

Stroke:

**8-155 mm**

Center Hole Diameter:

**19,6-79,0 mm**

Maximum Operating Pressure:

**700 bar**

### Optional Heat Treated Hollow Saddles

Saddle Type	Cylinder Model Number	Saddle Model Nr.	Saddle Dimensions (mm)		
			A	B	C
Threaded Hollow	RCH-202, 206	HP-2015	53	1" - 8	9
	RCH-302, 306	HP-3015	63	1 1/4" - 7	9
	RCH-603, 606	HP-5016	91	1 5/8" - 5 1/2	12
	RCH-1003	HP-10016	126	2 1/2" - 8	13

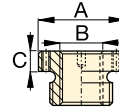

Smooth hollow saddles are standard on all RCH-models (except RCH-120, RCH-1211).

RCH-121 and RCH-1211 have a 47 mm dia. boss that protrudes 6 mm from base.

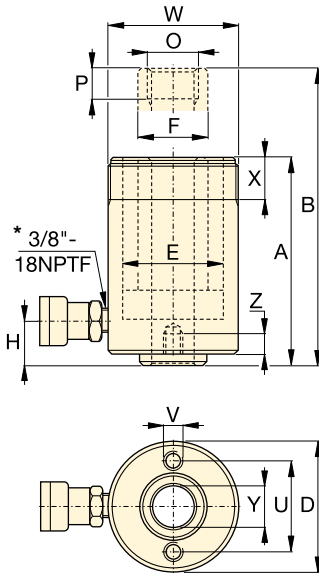

**RCH-120 to RCH-123 models**  
\* 1/4" NPTF for RCH-120 only

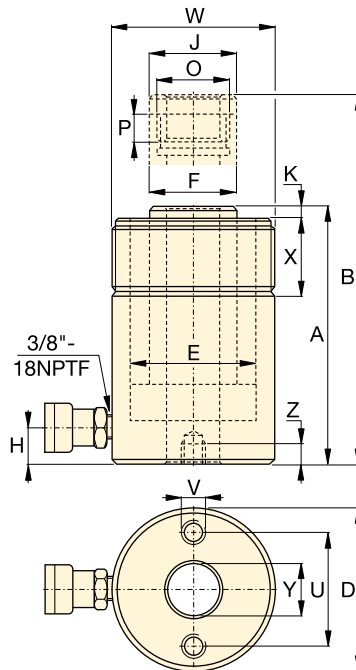

**RCH-202 to RCH-1003 models**

### Base Mounting Hole Dimensions (mm)

Model Number	Bolt Circle U	Thread V	Thread Depth Z
RCH-120	50,8	5/16" - 18 UNC	9,0
RCH-121	-	-	-
RCH-1211	-	-	-
RCH-123	50,8	5/16" - 18 UNC	12,7
RCH-202	82,6	3/8" - 16 UNC	9,4
RCH-206	82,6	3/8" - 16 UNC	9,4
RCH-302	92,2	3/8" - 16 UNC	14,0
RCH-306	92,2	3/8" - 16 UNC	14,0
RCH-603	130,3	1/2" - 13 UNC	14,0
RCH-606	130,3	1/2" - 13 UNC	14,0
RCH-1003	177,8	5/8" - 11 UNC	19,0

Coll. Height	Ext. Height	Out. Dia.	Cyl. Bore Dia.	Plgr. Dia.	Cyl. Base to Advance Port	Saddle Dia.	Saddle Protrusion from Plgr.	Plunger Internal Thread	Plunger Thread Length	Collar Thread	Collar Thread Length	Center Hole Dia.	Weight	Model Number
A	B	D	E	F	H	J	K	O	P	W	X	Y	(kg)	
(mm)	(mm)	(mm)	(mm)	(mm)	(mm)	(mm)	(mm)		(mm)		(mm)	(mm)		
55	63	69	54,1	35,1	9	-	-	3/4" - 16 UN	16	2 3/4" - 16	30	19,6	1,5	RCH-120
120	162	69	54,1	35,1	19	-	-	-	-	2 3/4" - 16	30	19,6	2,8	RCH-121*
120	162	69	54,1	35,1	19	-	-	3/4" - 16 UN	16	2 3/4" - 16	30	19,6	2,8	RCH-1211
184	260	69	54,1	35,1	19	-	-	-	-	2 3/4" - 16	30	19,6	4,4	RCH-123
162	211	98	73,1	54,1	19	54	9,7	1 9/16" - 16 UN	19	3 7/8" - 12	38	26,9	7,7	RCH-202*
306	461	98	73,1	54,1	25	54	9,7	1 9/16" - 16 UN	19	3 7/8" - 12	38	26,9	14,1	RCH-206
178	242	114	88,9	63,5	21	63	9,0	1 13/16" - 16 UN	22	4 1/2" - 12	42	33,3	10,9	RCH-302*
330	485	114	88,9	63,5	25	63	9,0	1 13/16" - 16 UN	22	4 1/2" - 12	42	33,3	21,8	RCH-306
247	323	159	123,9	91,9	31	91	12,0	2 3/4" - 16 UN	19	6 1/4" - 12	48	53,8	28,1	RCH-603*
323	476	159	123,9	91,9	31	91	12,0	2 3/4" - 16 UN	19	6 1/4" - 12	48	53,8	35,4	RCH-606
254	330	212	165,1	127,0	38	126	12,0	4" - 16 UN	25	8 3/8" - 12	60	79,0	63,0	RCH-1003*

# RRH-Series, Hollow Plunger Cylinders

▼ Shown from left to right: RRH-3010, RRH-1001, RRH-6010



- Relief valves prevent damage in case of over-pressurisation
- Baked enamel finish for increased corrosion resistance
- Collar threads enable easy fixturing (except RRH-1001 and RRH-1508)
- Double-acting version for fast retraction
- Nickel-plated, floating center tube increases product life
- Hollow plunger allows for both pull and push forces
- CR-400 coupler and dust cap included on all models
- Plunger wiper reduces contamination, extending cylinder life.

## Versatility in Testing, Maintenance and Tensioning Applications



### Pump Selection

A double-acting cylinder must be powered by a pump with a 4-way valve.

Page: 113



### Gauges

Minimize the risk of overloading and ensure long, dependable service from your equipment. Refer to the System Components Section for a full range of gauges.

Page: 118



### Saddles

All RRH-Series cylinders are equipped with smooth saddles. See table at next page for optional threaded saddles and all dimensional information.

Page: 29

▼ Double-acting hollow plunger cylinders are applied for bridge launching systems.

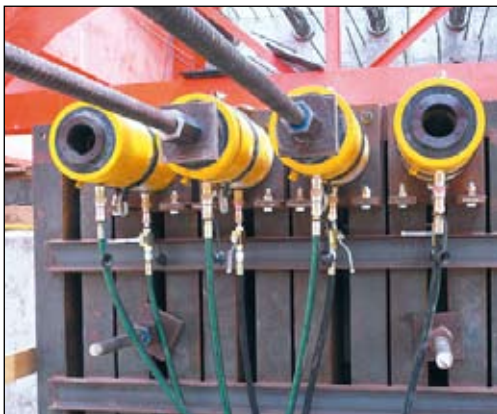

Cylinder Capacity	Stroke (mm)	Model Number	Max. Cylinder Capacity (kN)		Cylinder Effective Area (cm <sup>2</sup> )		Oil Capacity (cm <sup>3</sup> )	
			Advance	Retract	Advance	Retract	Advance	Retract
30 ton	178	RRH-307	326	213	46,6	30,4	829	541
	258	RRH-3010	326	213	46,6	30,4	1202	784
60 ton	89	RRH-603	576	380	82,3	54,2	733	482
	166	RRH-606	576	380	82,3	54,2	1366	900
	257	RRH-6010	576	380	82,3	54,2	2115	1393
95 ton	38	RRH-1001	931	612	133,0	87,4	505	333
	76	RRH-1003	931	612	133,0	87,4	1011	666
	153	RRH-1006	931	612	133,0	87,4	2035	1337
	257	RRH-10010	931	612	133,0	87,4	3420	2246
145 ton	203	RRH-1508	1429	718	204,1	102,6	4144	2083

# Double-Acting, Hollow Plunger Cylinders



## Hoses

Enerpac offers a complete line of high quality hydraulic hoses. To ensure the integrity of your system, specify only Enerpac hydraulic hoses.

Page: 120

## RRH Series



Capacity:

**30 - 145 ton**

Stroke:

**38 - 258 mm**

Center Hole Diameter:

**33,3-79,2 mm**

Maximum Operating Pressure:

**700 bar**

Optional Heat Treated Hollow Saddles					
Saddle Type	Cylinder Model Number	Saddle Model Nr.	Saddle Dimensions (mm)		
			A	B	C
Threaded Hollow	RRH-307, 3010	HP-3015	63	1 1/4" - 7	9
	RRH-603, 606, 6010	HP-5016	91	1 5/8" - 5 1/2	12
	RRH-1001, 1003, RRH-1006, 10010	HP-10016	126	2 1/2" - 8	13

Smooth hollow saddles are standard on all RRH-models.

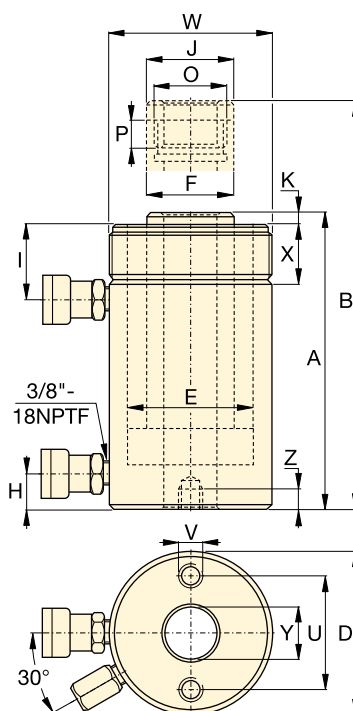

Base Mounting Hole Dimensions (mm)			
Model Number	Bolt Circle U	Thread V	Thread Depth Z
RRH-307	92,2	3/8" - 16	15,7
RRH-3010	92,2	3/8" - 16	15,7
RRH-603	130,0	1/2" - 13	14,0
RRH-606	130,0	1/2" - 13	14,0
RRH-6010	130,0	1/2" - 13	14,0
RRH-1001	177,8	5/8" - 11	19,0
RRH-1003	177,8	5/8" - 11	19,0
RRH-1006	177,8	5/8" - 11	19,0
RRH-10010	177,8	5/8" - 11	19,0
RRH-1508	-	-	-

Coll. Height	Ext. Height	Out. Dia.	Cyl. Bore Dia.	Plgr. Dia.	Cyl. Base to Adv. Port	Cyl. Top to Return Port	Saddle Dia.	Saddle Protr. fr. Plgr.	Thread	Plunger Thread Length	Collar Thread	Collar Thread Length	Center Hole Dia.	Weight (kg)	Model Number
A (mm)	B (mm)	D (mm)	E (mm)	F (mm)	H (mm)	I (mm)	J (mm)	K (mm)	O	P (mm)	W	X (mm)	Y (mm)	(kg)	
330	508	114	88,9	63,5	25	60	63	9	1 13/16" - 16	22	4 1/2" - 12	42	33,3	21	RRH-307
431	689	114	88,9	63,5	25	60	63	9	1 13/16" - 16	22	4 1/2" - 12	42	33,3	27	RRH-3010
247	336	159	123,9	91,9	31	66	91	12	2 3/4" - 16	19	6 1/4" - 12	48	53,8	28	RRH-603
323	489	159	123,9	91,9	31	66	91	12	2 3/4" - 16	19	6 1/4" - 12	48	53,8	35	RRH-606
438	695	159	123,9	91,9	31	66	91	12	2 3/4" - 16	19	6 1/4" - 12	48	53,8	45	RRH-6010
165	203	212	165,1	127,0	38	44	126	12	4" - 16	25	-	-	79,2	33	RRH-1001
254	330	212	165,1	127,0	38	85	126	12	4" - 16	25	8 3/8" - 12	60	79,2	61	RRH-1003
342	495	212	165,1	127,0	38	85	126	12	4" - 16	25	8 3/8" - 12	60	79,2	79	RRH-1006
460	717	212	165,1	127,0	38	85	126	12	4" - 16	25	8 3/8" - 12	60	79,2	106	RRH-10010
349	552	247	190,5	152,4	38	60	127	4	4 1/4" - 12	25	-	-	79,2	111	RRH-1508



▼ Shown from left to right: BRD-2510, BRD-96, BRD-256, BRD-41, BRD-166



## High Precision and High Cycle Performance



### Speed Chart

See the Enerpac Cylinder Speed Chart in our 'Yellow Pages' to determine your approximate cylinder speed.

Page: **249**



### Golden Ring Design

Enerpac BRD-Cylinders are provided with the Golden Ring Design, for long, trouble-free performance.

- The exclusive Golden Ring Design absorbs eccentric loading without galling cylinder parts
- Designed for long life, the best choice for production applications
- Unique mounting configurations simplify fixturing
- Baked enamel finish for increased corrosion resistance
- Double-acting operation develops force in both directions, providing maximum versatility
- Plunger wiper reduces contamination, extending cylinder life
- Imperial models (RD-series) available on request.

▼ Clamping application using Enerpac BRD cylinders (with clevis eye attachments on both ends) for their high pressure capability and mounting flexibility.



Cylinder Capacity (ton)	Stroke (mm)	Model Number	Max. Cylinder Capacity (kN)		Cylinder Effective Area (cm <sup>2</sup> )		Oil Capacity (cm <sup>3</sup> )		Coll. Height A (mm)	Ext. Height B (mm)	Body Length C (mm)	Out. Dia. D (mm)	Cyl. Bore Dia. E (mm)	Plgr. Dia. F (mm)
			Advance	Retract	Advance	Retract	Advance	Retract						
4	28	<b>BRD-41</b>	35	16	5,1	2,2	14	6	186	214	162	50	25,4	19,0
	79	<b>BRD-43</b>	35	16	5,1	2,2	40	17	237	316	213	50	25,4	19,0
	155	<b>BRD-46</b>	35	16	5,1	2,2	79	34	313	468	289	50	25,4	19,0
8	28	<b>BRD-91</b>	80	44	11,4	6,3	32	18	223	251	198	65	38,1	25,4
	79	<b>BRD-93</b>	80	44	11,4	6,3	90	50	274	353	249	65	38,1	25,4
	155	<b>BRD-96</b>	80	44	11,4	6,3	177	98	350	505	325	65	38,1	25,4
	257	<b>BRD-910</b>	80	44	11,4	6,3	293	162	452	709	427	65	38,1	25,4
15	159	<b>BRD-166</b>	142	77	20,3	10,6	323	169	389	548	359	80	50,8	35,0
	260	<b>BRD-1610</b>	142	77	20,3	10,6	528	276	491	751	461	80	50,8	35,0
23	159	<b>BRD-256</b>	222	98	31,7	13,7	504	218	424	583	397	92	63,5	47,8
	260	<b>BRD-2510</b>	222	98	31,7	13,7	824	356	526	786	499	92	63,5	47,8

# Double-Acting, Precision Production Cylinders

## ▼ BRD CYLINDER ATTACHMENTS

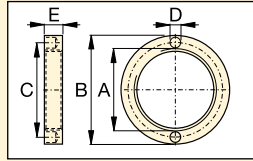

**Retainer Nut**  
For locking foot or flange mountings. Tightens onto cylinder collar threads (Included with foot and flange mounting kits).

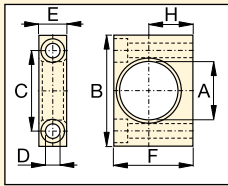

**Foot Mounting**  
Mounts onto cylinder collar.

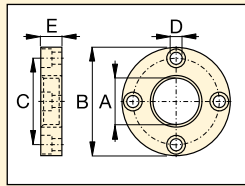

**Flange Mounting**  
Mounts onto cylinder collar.

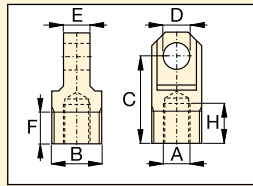

**Clevis Eye**  
Threads onto plunger or into cylinder base.

Model Number	BRD-Cyl. (ton)	Dimensions (mm)						
		A	B	C	D	E	F	H
<b>Foot Mounting with Retainer Nut</b>								
BAD-141	4	42,1	80	58,0	10,5	20,0	57,0	31,8
BAD-171	8	56,1	105	78,0	13,5	25,0	82,5	44,5
BAD-181	15	70,1	127	95,2	20,0	35,0	100,0	52,4
BAD-191	23	85,1	159	117,5	26,5	45,0	125,0	63,5
<b>Flange Mounting with Retainer Nut</b>								
BAD-142	4	42,1	98,4	78,6	11,0	19,0	-	-
BAD-172	8	56,1	121	98,4	11,0	25,4	-	-
BAD-182	15	70,1	143	115,9	16,0	35,0	-	-
BAD-192	23	85,1	159	135,7	17,0	44,5	-	-
<b>Retainer Nut</b>								
BAD-143	4	M42 x 1,5	57	49,5	6,3	9,5	-	-
BAD-173	8	M56 x 2	75	65,5	6,7	12,7	-	-
BAD-183	15	M70 x 2	92	81,0	6,7	19,0	-	-
BAD-193	23	M85 x 2	108	96,5	6,7	25,4	-	-
<b>Clevis Eye (See chart below for mounting dimensions L, L1 and M)</b>								
BAD-150	4	M16 x 1,5	M30 x 1,5	52,4	16,0	15,9	19,1	23,8
BAD-151	8	M22 x 1,5	M42 x 1,5	57,1	20,0	25,4	25,4	23,8
BAD-152	15	M30 x 1,5	M56 x 2	77,8	25,0	31,8	25,4	30,2
BAD-153	23	M42 x 1,5	M70 x 2	77,8	32,0	38,2	25,4	27,0

## BRD Series



Capacity:  
**4 - 23 ton**

Stroke:  
**28 - 260 mm**

Maximum Operating Pressure:  
**700 bar**

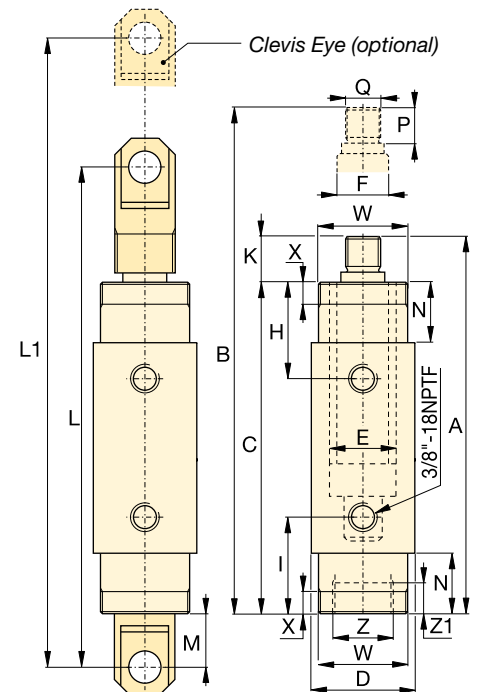

Top to Retract Port H (mm)	Bottom to Advance Port I (mm)	Plunger Protrusion K (mm)	Clevis Eye Mounting Dimensions			Neck Length N (mm)	Plunger Thread Length P (mm)	Plunger External Thread Q (mm)	Cylinder Mounting Dimensions (mm)				Model Number	
			L (mm)	L1 (mm)	M (mm)				Collar Thread W	Collar Thread Length X	Int. Base Thread Z	Int. Base Thread Length Z1		
47	47	24	258	286	41	29	22	M16 x 1,5	M42 x 1,5	11	M30 x 1,5	9	2,0	BRD-41
47	47	24	308	387	41	29	22	M16 x 1,5	M42 x 1,5	11	M30 x 1,5	9	2,6	BRD-43
47	47	24	385	540	41	29	22	M16 x 1,5	M42 x 1,5	11	M30 x 1,5	9	3,6	BRD-46
57	57	25	295	323	38	38	22	M22 x 1,5	M56 x 2	14	M42 x 1,5	14	3,0	BRD-91
57	57	25	346	425	38	38	22	M22 x 1,5	M56 x 2	14	M42 x 1,5	14	4,2	BRD-93
57	57	25	422	577	38	38	22	M22 x 1,5	M56 x 2	14	M42 x 1,5	14	5,6	BRD-96
57	57	25	524	781	38	38	22	M22 x 1,5	M56 x 2	14	M42 x 1,5	14	7,3	BRD-910
73	73	30	492	651	52	54	28	M30 x 1,5	M70 x 2	22	M56 x 2	24	10,2	BRD-166
73	73	30	593	853	52	54	28	M30 x 1,5	M70 x 2	22	M56 x 2	24	14,5	BRD-1610
89	89	27	524	683	53	70	25	M42 x 1,5	M85 x 2	29	M70 x 2	26	16,0	BRD-256
89	89	27	626	886	53	70	25	M42 x 1,5	M85 x 2	29	M70 x 2	26	20,3	BRD-2510

# RR-Series, Double-Acting Cylinders

▼ Shown from left to right: RR-10013, RR-1502, RR-20013, RR-1010, RR-7513



- Collar threads, plunger threads and base mounting holes for easy fixturing (on most models)
- Baked enamel finish for increased corrosion resistance
- Removable hardened saddles protect plunger during lifting and pressing
- Built-in safety valve prevents accidental over-pressurization
- CR-400 couplers included on all models
- Plunger wiper reduces contamination, extending cylinder life.

▼ These long stroke RR-cylinders are attached in a sliding and guiding system pulling the arched roof assembly of Athens Olympic Stadium step by step into the final position.



## Most Versatile Performers

Rugged enough for the toughest job site uses and precision designed for high-cycle industrial uses



### Saddles

RR-Series cylinders up to 75 ton have plunger mounting holes for installation of CAT-Series tilt saddles.

Page: **33**



### Optimum Performance

Enerpac's range of Z-Class electric pumps, fitted with manual or solenoid operated 4-way valves, offer optimum combinations with RR-Series cylinders.

Page: **84**

▼ RR-cylinders provide power and precision in a special hydraulic press.



# Double-Acting Long Stroke Cylinders

## RR Series



### ▼ QUICK SELECTION CHART

For complete technical information see next page.

Cylinder Capacity ton (kN)	Stroke (mm)	Model Number	Cylinder Effective Area (cm <sup>2</sup> )		Oil Capacity (cm <sup>3</sup> )		Coll. Height (mm)
			Push	Pull	Push	Pull	
10 (101)	254	RR-1010	14,5	4,8	368	122	409
	305	RR-1012	14,5	4,8	442	147	457
30 (295)	209	RR-308	42,1	19,1	879	400	395
	368	RR-3014	42,1	19,1	1549	703	549
50 (498)	156	RR-506	71,2	21,5	1111	335	331
	334	RR-5013	71,2	21,5	2378	718	509
	511	RR-5020	71,2	21,5	3638	1099	733
75 (718)	156	RR-756	102,6	31,4	1601	490	347
	333	RR-7513	102,6	31,4	3417	1046	525
95 (933)	168	RR-1006	133,3	62,2	2238	1045	357
	333	RR-10013	133,3	62,2	4439	2071	524
	460	RR-10018	133,3	62,2	6132	2861	687
140 (1386)	57	RR-1502	198,1	95,4	1129	544	196
	156	RR-1506	198,1	95,4	3090	1488	385
	333	RR-15013	198,1	95,4	6597	3177	582
	815	RR-15032	198,1	95,4	16145	7775	1116
200 (1995)	152	RR-2006	285,0	145,3	4332	2209	430
	330	RR-20013	285,0	145,3	9405	4795	608
	457	RR-20018	285,0	145,3	13025	6640	765
	610	RR-20024	285,0	145,3	17385	8863	917
	914	RR-20036	285,0	145,3	26049	13280	1222
325 (3201)	1219	RR-20048	285,0	145,3	34741	17712	1527
	153	RR-3006	457,3	243,2	6997	3721	485
	305	RR-30012	457,3	243,2	13947	7418	638
	457	RR-30018	457,3	243,2	20889	11114	790
	609	RR-30024	457,3	243,2	27850	14811	943
	915	RR-30036	457,3	243,2	41843	22253	1247
440 (4292)	1219	RR-30048	457,3	243,2	55745	29646	1552
	152	RR-4006	613,1	328,1	9319	4987	538
	305	RR-40012	613,1	328,1	18700	10007	690
	457	RR-40018	613,1	328,1	28018	14995	843
	610	RR-40024	613,1	328,1	37400	20014	995
	914	RR-40036	613,1	328,1	56037	29988	1300
520 (5108)	1219	RR-40048	613,1	328,1	74737	39996	1605
	153	RR-5006	729,7	405,4	11164	6203	577
	305	RR-50012	729,7	405,4	22256	12365	730
	457	RR-50018	729,7	405,4	33347	18526	882
	609	RR-50024	729,7	405,4	44440	24689	1035
	915	RR-50036	729,7	405,4	66768	36973	1339
	1219	RR-50048	729,7	405,4	88951	49418	1644

Capacity:

**10 - 520 ton**

Stroke:

**57 - 1219 mm**

Maximum Operating Pressure:

**700 bar**



#### Enerpac CLRG-Series

If your application does not require high cycle, Enerpac CLRG-Series cylinders may be the right alternative.

Page: 44



#### Speed Chart

See the Enerpac Cylinder Speed Chart in our 'Yellow Pages' to determine your approximate cylinder speed.

Page: 249



#### Optional Snap-in Saddles

Optional snap-in saddles for RR-Series double-acting cylinders:

Saddle Type	Cylinder Model Number	Saddle Model Number
Flat	RR-1010, 1012	A-102F
	RR-308, 3014	CAT-50
Tilt	RR-506, 5013	CAT-100
	RR-5020, 756	
	RR-7513	

#### Standard Saddles:

Grooved	RR-1010, 1012	A-102G
	RR-308, 3014	A-252G

For additional information on saddles:

Page: 10



# RR-Series, Double-Acting Cylinders

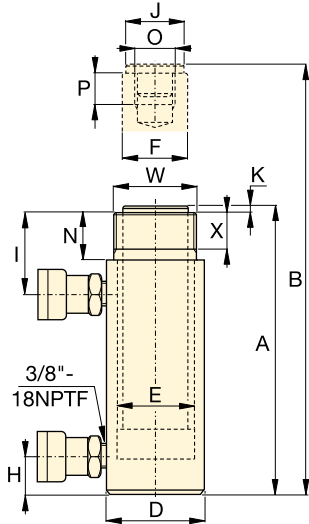

**RR-1010 - RR-3014**

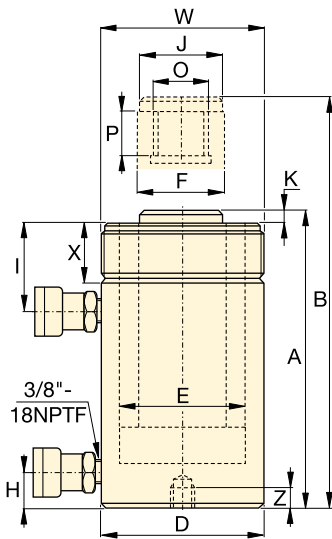

**RR-506 - RR-50048**

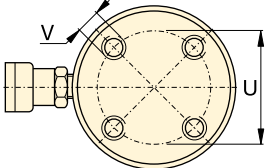

**RR-1006 - RR-30048**

No mounting holes on:  
RR-506, 5013  
RR-756, 7513  
RR-1502, 15013

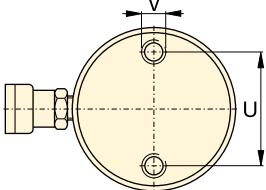

**RR-4006 - RR-50048**

Base mounting hole location is for reference only, as it is affected by assembly.



Cylinder retract capacity for certain RR cylinders may be less than theoretical values, as a result of reduced relief valve pressure settings:

- RR-308/3014: 275 bar
- RR-506/5013/5020: 480 bar
- RR-756/7513: 495 bar

◀ For full features see previous page.

Cylinder Capacity	Stroke (mm)	Model Number	Max. Cylinder Capacity (kN)		Cylinder Effective Area (cm <sup>2</sup> )		Oil Capacity (cm <sup>3</sup> )		Coll. Height	Ext. Height	Outside Dia.
			Push	Pull	Push	Pull	Push	Pull	A (mm)	B (mm)	D (mm)
10	254	RR-1010*	101	33	14,5	4,8	368	122	409	663	73
	305	RR-1012*	101	33	14,5	4,8	442	147	457	762	73
30	209	RR-308*	295	53	42,1	19,1	879	400	395	604	101
	368	RR-3014*	295	53	42,1	19,1	1549	703	549	917	101
50	156	RR-506	498	103	71,2	21,5	1111	335	331	487	127
	334	RR-5013	498	103	71,2	21,5	2378	718	509	843	127
	511	RR-5020	498	103	71,2	21,5	3638	1099	733	1244	127
75	156	RR-756	718	156	102,6	31,4	1601	490	347	503	146
	333	RR-7513	718	156	102,6	31,4	3417	1046	525	858	146
95	168	RR-1006	933	435	133,3	62,2	2238	1045	357	525	177
	333	RR-10013	933	435	133,3	62,2	4439	2071	524	857	177
	460	RR-10018	933	435	133,3	62,2	6132	2861	687	1147	177
140	57	RR-1502	1386	668	198,1	95,4	1129	544	196	253	203
	156	RR-1506	1386	668	198,1	95,4	3090	1488	385	541	203
	333	RR-15013	1386	668	198,1	95,4	6597	3177	582	915	203
	815	RR-15032	1386	668	198,1	95,4	16145	7775	1116	1931	203
200	152	RR-2006	1995	1017	285,0	145,3	4332	2209	430	582	247
	330	RR-20013	1995	1017	285,0	145,3	9405	4795	608	938	247
	457	RR-20018	1995	1017	285,0	145,3	13025	6640	765	1222	247
	610	RR-20024	1995	1017	285,0	145,3	17385	8863	917	1527	247
	914	RR-20036	1995	1017	285,0	145,3	26049	13280	1222	2136	247
	1219	RR-20048	1995	1017	285,0	145,3	34741	17712	1527	2746	247
325	153	RR-3006	3201	1703	457,3	243,2	6997	3721	485	638	311
	305	RR-30012	3201	1703	457,3	243,2	13947	7418	638	943	311
	457	RR-30018	3201	1703	457,3	243,2	20889	11114	790	1247	311
	609	RR-30024	3201	1703	457,3	243,2	27850	14811	943	1552	311
	915	RR-30036	3201	1703	457,3	243,2	41843	22253	1247	2162	311
	1219	RR-30048	3201	1703	457,3	243,2	55745	29646	1552	2771	311
440	152	RR-4006	4292	2297	613,1	328,1	9319	4987	538	690	358
	305	RR-40012	4292	2297	613,1	328,1	18700	10007	690	995	358
	457	RR-40018	4292	2297	613,1	328,1	28018	14995	843	1300	358
	610	RR-40024	4292	2297	613,1	328,1	37400	20014	995	1605	358
	914	RR-40036	4292	2297	613,1	328,1	56037	29988	1300	2214	358
	1219	RR-40048	4292	2297	613,1	328,1	74737	39996	1605	2824	358
520	153	RR-5006	5108	2838	729,7	405,4	11164	6203	577	730	397
	305	RR-50012	5108	2838	729,7	405,4	22256	12365	730	1035	397
	457	RR-50018	5108	2838	729,7	405,4	33347	18526	882	1339	397
	609	RR-50024	5108	2838	729,7	405,4	44440	24689	1035	1644	397
	915	RR-50036	5108	2838	729,7	405,4	66768	36973	1339	2254	397
	1219	RR-50048	5108	2838	729,7	405,4	88951	49418	1644	2863	397

\* For RR-1010 and RR-1012: N = 32 mm; for RR-308 and RR-3014: N = 55 mm.

# Double-Acting Long Stroke Cylinders

Capacity:  
**10 - 520 ton**

Stroke:  
**57 - 1219 mm**

Maximum Operating Pressure:  
**700 bar**

**RR**  
Series



	Cyl. Bore Dia. E (mm)	Plgr. Dia. F (mm)	Base to Adv. Port H (mm)	Top to Ret. Port I (mm)	Saddle Dia. J (mm)	Saddle Protr. fr. Plgr. K (mm)	Plunger Internal Thread O	Plunger Thread Length P (mm)	Base Mounting Holes			Collar Thread W	Collar Thread Length X (mm)	 (kg)	Model Number
									Bolt C. Dia. U (mm)	Thread V	Thd. Depth Z (mm)				
	42,9	34,9	36	57	35	6	1" - 8	25	-	-	-	2 1/4" - 14	26	12	RR-1010*
	42,9	34,9	36	57	35	6	1" - 8	25	-	-	-	2 1/4" - 14	26	14	RR-1012*
	73,2	54,1	39	81	50	10	1 1/2" - 16	25	-	-	-	3 5/16" - 12	49	18	RR-308*
	73,2	54,1	39	81	50	10	1 1/2" - 16	25	-	-	-	3 5/16" - 12	49	29	RR-3014*
	95,2	79,5	28	76	71	2	1" - 12	25	-	-	-	5" - 12	44	30	RR-506
	95,2	79,5	28	76	71	2	1" - 12	25	-	-	-	5" - 12	44	52	RR-5013
	95,2	79,5	57	76	71	2	1" - 12	25	76	1/2" - 13	25	5" - 12	44	68	RR-5020
	114,3	95,2	30	76	71	6	1" - 12	38	-	-	-	5 3/4" - 12	38	41	RR-756
	114,3	95,2	30	81	71	6	1" - 12	38	-	-	-	5 3/4" - 12	38	68	RR-7513
	130,3	95,2	38	71	76	3	1 3/4" - 12	35	139	3/4" - 10	25	6 7/8" - 12	50	61	RR-1006
	130,3	95,2	38	71	76	3	1 3/4" - 12	35	139	3/4" - 10	25	6 7/8" - 12	50	93	RR-10013
	130,3	95,2	41	92	76	3	1 3/4" - 12	35	139	3/4" - 10	25	6 7/8" - 12	50	117	RR-10018
	158,8	114,3	22	66	95	19	-	-	-	-	-	-	-	49	RR-1502
	158,8	114,3	49	84	114	19	3 3/8" - 16	35	158	3/4" - 16	28	8" - 12	55	93	RR-1506
	158,8	114,3	49	84	114	19	3 3/8" - 16	35	158	3/4" - 16	28	8" - 12	55	124	RR-15013
	158,8	114,3	76	88	114	19	3 3/8" - 16	35	-	-	-	8" - 12	55	238	RR-15032
	190,5	133,4	57	96	133	22	-	-	127	1" - 8	25	-	-	147	RR-2006
	190,5	133,4	57	96	133	22	2 1/2" - 12	63	127	1" - 8	25	9 3/4" - 12	54	199	RR-20013
	190,5	133,4	85	101	133	22	2 1/2" - 12	63	127	1" - 8	25	9 3/4" - 12	54	204	RR-20018
	190,5	133,4	85	101	133	22	2 1/2" - 12	63	127	1" - 8	25	9 3/4" - 12	54	279	RR-20024
	190,5	133,4	85	101	133	22	2 1/2" - 12	63	127	1" - 8	25	9 3/4" - 12	54	383	RR-20036
	190,5	133,4	85	101	133	22	2 1/2" - 12	63	127	1" - 8	25	9 3/4" - 12	54	483	RR-20048
	241,3	165,1	88	114	165	28	2 1/2" - 12	82	158	1 1/4" - 7	44	12 1/4" - 12	58	200	RR-3006
	241,3	165,1	88	114	165	28	2 1/2" - 12	82	158	1 1/4" - 7	44	12 1/4" - 12	58	312	RR-30012
	241,3	165,1	88	114	165	28	2 1/2" - 12	82	158	1 1/4" - 7	44	12 1/4" - 12	58	385	RR-30018
	241,3	165,1	88	114	165	28	2 1/2" - 12	82	158	1 1/4" - 7	44	12 1/4" - 12	58	469	RR-30024
	241,3	165,1	88	114	165	28	2 1/2" - 12	82	158	1 1/4" - 7	44	12 1/4" - 12	58	628	RR-30036
	241,3	165,1	88	114	165	28	2 1/2" - 12	82	158	1 1/4" - 7	44	12 1/4" - 12	58	780	RR-30048
	279,4	190,5	108	133	190	28	3" - 12	95	203	1 1/2" - 6	50	14 1/8" - 8	65	303	RR-4006
	279,4	190,5	108	133	190	28	3" - 12	95	203	1 1/2" - 6	50	14 1/8" - 8	65	399	RR-40012
	279,4	190,5	108	133	190	28	3" - 12	95	203	1 1/2" - 6	50	14 1/8" - 8	65	453	RR-40018
	279,4	190,5	108	133	190	28	3" - 12	95	203	1 1/2" - 6	50	14 1/8" - 8	65	597	RR-40024
	279,4	190,5	108	133	190	28	3" - 12	95	203	1 1/2" - 6	50	14 1/8" - 8	65	792	RR-40036
	279,4	190,5	108	133	190	28	3" - 12	95	203	1 1/2" - 6	50	14 1/8" - 8	65	980	RR-40048
	304,8	203,2	120	152	203	28	3 1/4" - 12	108	203	1 3/4" - 5	57	15 5/8" - 8	79	432	RR-5006
	304,8	203,2	120	152	203	28	3 1/4" - 12	108	203	1 3/4" - 5	57	15 5/8" - 8	79	589	RR-50012
	304,8	203,2	120	152	203	28	3 1/4" - 12	108	203	1 3/4" - 5	57	15 5/8" - 8	79	680	RR-50018
	304,8	203,2	120	152	203	28	3 1/4" - 12	108	203	1 3/4" - 5	57	15 5/8" - 8	79	816	RR-50024
	304,8	203,2	120	152	203	28	3 1/4" - 12	108	203	1 3/4" - 5	57	15 5/8" - 8	79	1002	RR-50036
	304,8	203,2	120	152	203	28	3 1/4" - 12	108	203	1 3/4" - 5	57	15 5/8" - 8	79	1224	RR-50048

# CLSG-Series, High Tonnage Cylinders

▼ Shown from left to right: CLSG-506, CLSG-5006, CLSG-4006



- Integral stop ring provides piston blow-out protection
- Baked enamel outside finish and plated pistons provide superior corrosion protection
- Interchangeable, hardened grooved saddles are standard
- Base mounting holes are standard on all models
- Plunger wiper reduces contamination, extending cylinder life
- Single-acting, load return.

▼ Eight CLSG-2506 cylinders equipped with tilting saddles lifted the planking of the bridge as the pier heads were being rebuilt.



## The Single-Acting Heavy Lifting Solution with Integral Stop Ring



### Saddles

All CLSG-Series cylinders are equipped with bolt-on removable grooved saddles. For information on optional tilt saddles, see selection chart.

Page: **39**



### Gauges

Minimize the risk of overloading and ensure long, dependable service from your equipment. Refer to the

System Components Section for a full range of gauges.

Page: **118**



### Optimum Performance

Enerpac's range of Z-Class electric pumps, fitted with manual or solenoid operated 4-way valves, offer optimum combinations with CLSG cylinders.

Page: **84**



### Low Height - High Tonnage

When low height with high force is required, CLP-Series Pancake Cylinders with locknut offer the solution to lift the first few centimetres.

Page: **20**



### Standard Features

- Interchangeable, hardened grooved saddles
- Top and side mounted lifting eye capability
- CR-400 coupler and dustcap
- All cylinders meet ASME B-30.1 and ISO 10100 standards.

# Single-Acting, High Tonnage Cylinders

## ▼ QUICK SELECTION CHART

For complete technical information see next page.

Cylinder Capacity	Stroke	Model Number	Cylinder Effective Area	Oil Capacity	Collapsed Height	
ton (kN)	(mm)		(cm <sup>2</sup> )	(cm <sup>3</sup> )	(mm)	(kg)
<b>50</b> (539)	50	<b>CLSG-502</b>	77,0	385	162	17
	100	<b>CLSG-504</b>	77,0	770	212	20
	150	<b>CLSG-506</b>	77,0	1155	262	23
	200	<b>CLSG-508</b>	77,0	1540	312	27
	250	<b>CLSG-5010</b>	77,0	1924	362	31
	300	<b>CLSG-5012</b>	77,0	2309	412	34
<b>100</b> (929)	50	<b>CLSG-1002</b>	132,7	664	182	19
	100	<b>CLSG-1004</b>	132,7	1327	232	29
	150	<b>CLSG-1006</b>	132,7	1991	282	40
	200	<b>CLSG-1008</b>	132,7	2655	332	50
	250	<b>CLSG-10010</b>	132,7	3318	382	61
	300	<b>CLSG-10012</b>	132,7	3982	432	71
<b>150</b> (1390)	50	<b>CLSG-1502</b>	198,6	993	196	39
	100	<b>CLSG-1504</b>	198,6	1986	246	52
	150	<b>CLSG-1506</b>	198,6	2978	296	65
	200	<b>CLSG-1508</b>	198,6	3971	346	78
	250	<b>CLSG-15010</b>	198,6	4964	396	92
	300	<b>CLSG-15012</b>	198,6	5957	446	105
<b>200</b> (1861)	50	<b>CLSG-2002</b>	265,9	1330	216	55
	150	<b>CLSG-2006</b>	265,9	3989	316	91
	300	<b>CLSG-20012</b>	265,9	7977	466	146
<b>250</b> (2565)	50	<b>CLSG-2502</b>	366,4	1832	235	102
	150	<b>CLSG-2506</b>	366,4	5497	335	136
	300	<b>CLSG-25012</b>	366,4	10993	485	207
<b>300</b> (3193)	50	<b>CLSG-3002</b>	456,2	2281	312	184
	150	<b>CLSG-3006</b>	456,2	6843	412	232
	300	<b>CLSG-30012</b>	456,2	13685	562	303
<b>400</b> (3919)	50	<b>CLSG-4002</b>	559,9	2800	375	270
	150	<b>CLSG-4006</b>	559,9	8399	475	330
	300	<b>CLSG-40012</b>	559,9	16797	625	421
<b>500</b> (5114)	50	<b>CLSG-5002</b>	730,6	3653	419	401
	150	<b>CLSG-5006</b>	730,6	10959	519	480
	300	<b>CLSG-50012</b>	730,6	21918	669	599
<b>600</b> (5987)	50	<b>CLSG-6002</b>	855,3	4276	429	474
	150	<b>CLSG-6006</b>	855,3	12829	529	565
	300	<b>CLSG-60012</b>	855,3	25659	679	701
<b>800</b> (8234)	50	<b>CLSG-8002</b>	1176,3	5881	474	741
	150	<b>CLSG-8006</b>	1176,3	17644	574	880
	300	<b>CLSG-80012</b>	1176,3	35288	724	1058
<b>1000</b> (10260)	50	<b>CLSG-10002</b>	1465,7	7329	564	1062
	150	<b>CLSG-10006</b>	1465,7	21986	664	1213
	300	<b>CLSG-100012</b>	1465,7	43972	814	1439

## CLSG Series



Capacity:

**50 - 1000 ton**

Stroke:

**50 - 300 mm**

Maximum Operating Pressure:

**700 bar**



### Higher Capacities

1500 and 2000 ton models available on request.

### Additional Stroke Lengths

Models above 150 ton are also available with standard stroke lengths of 100, 200 and 250 mm. Please contact Enerpac for ordering information.



### Lifting an Unbalanced Load?

When lifting an unbalanced load **Enerpac Integrated Lifting Systems** can be

the solution with multiple lift point capabilities from 4 to 64 points. See our "Yellow Pages" for multi-cylinder set-ups.

Page: **244**



### Optional features

To add optional features to your cylinders, add the following suffix to the end of the model number.

Collar thread \*

**E002**

\* On 400 ton models and higher.

Example:

- For CLSG-5006 cylinder with collar thread, order: **CLSG-5006E002**

Technical specifications for these features are available from Enerpac.



# CLSG-Series, High Tonnage Cylinders



### Mounting Hole Orientation

Top mounting hole orientation is maintained to port location. Base mounting hole orientation is not maintained to port location.

◀ For full features see previous page.

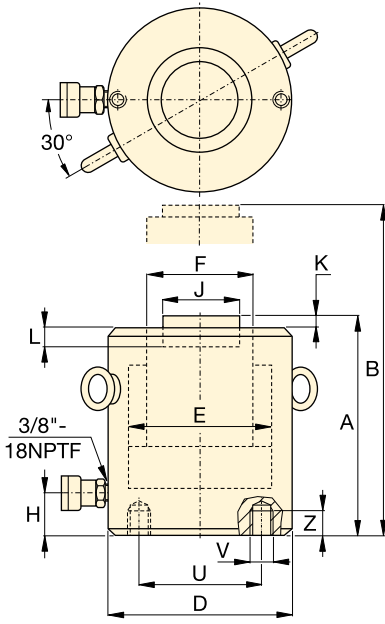

**CLSG-502 - CLSG-15012**

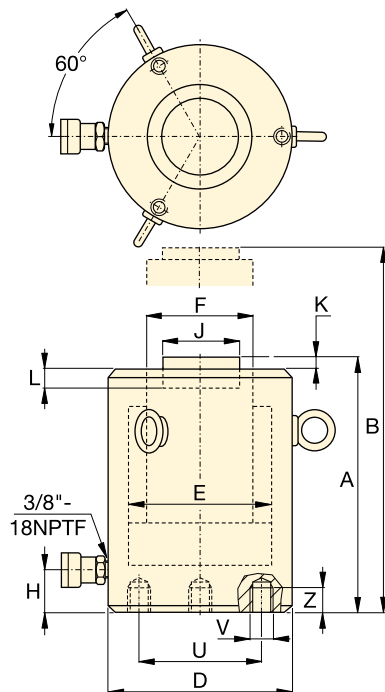

**CLSG-2002 - CLSG-100012**

Cylinder Capacity	Stroke	Model Number	Cylinder Effective Area	Oil Capacity
ton (kN)	(mm)		(cm <sup>2</sup> )	(cm <sup>3</sup> )
<b>50</b> (539)	50	<b>CLSG-502</b>	77,0	385
	100	<b>CLSG-504</b>	77,0	770
	150	<b>CLSG-506</b>	77,0	1155
	200	<b>CLSG-508</b>	77,0	1540
	250	<b>CLSG-5010</b>	77,0	1924
	300	<b>CLSG-5012</b>	77,0	2309
<b>100</b> (929)	50	<b>CLSG-1002</b>	132,7	664
	100	<b>CLSG-1004</b>	132,7	1327
	150	<b>CLSG-1006</b>	132,7	1991
	200	<b>CLSG-1008</b>	132,7	2655
	250	<b>CLSG-10010</b>	132,7	3318
	300	<b>CLSG-10012</b>	132,7	3982
<b>150</b> (1390)	50	<b>CLSG-1502</b>	198,6	993
	100	<b>CLSG-1504</b>	198,6	1986
	150	<b>CLSG-1506</b>	198,6	2978
	200	<b>CLSG-1508</b>	198,6	3971
	250	<b>CLSG-15010</b>	198,6	4964
	300	<b>CLSG-15012</b>	198,6	5957
<b>200</b> (1861)	50	<b>CLSG-2002</b>	265,9	1330
	150	<b>CLSG-2006</b>	265,9	3989
	300	<b>CLSG-20012</b>	265,9	7977
<b>250</b> (2565)	50	<b>CLSG-2502</b>	366,4	1832
	150	<b>CLSG-2506</b>	366,4	5497
	300	<b>CLSG-25012</b>	366,4	10993
<b>300</b> (3193)	50	<b>CLSG-3002</b>	456,2	2281
	150	<b>CLSG-3006</b>	456,2	6843
	300	<b>CLSG-30012</b>	456,2	13685
<b>400</b> (3919)	50	<b>CLSG-4002</b>	559,9	2800
	150	<b>CLSG-4006</b>	559,9	8399
	300	<b>CLSG-40012</b>	559,9	16797
<b>500</b> (5114)	50	<b>CLSG-5002</b>	730,6	3653
	150	<b>CLSG-5006</b>	730,6	10959
	300	<b>CLSG-50012</b>	730,6	21918
<b>600</b> (5987)	50	<b>CLSG-6002</b>	855,3	4276
	150	<b>CLSG-6006</b>	855,3	12829
	300	<b>CLSG-60012</b>	855,3	25659
<b>800</b> (8234)	50	<b>CLSG-8002</b>	1176,3	5881
	150	<b>CLSG-8006</b>	1176,3	17644
	300	<b>CLSG-80012</b>	1176,3	35288
<b>1000</b> (10260)	50	<b>CLSG-10002</b>	1465,7	7329
	150	<b>CLSG-10006</b>	1465,7	21986
	300	<b>CLSG-100012</b>	1465,7	43972

Base Mounting Hole <sup>1)</sup> Dimensions (mm)			
Model / Capacity ton	Bolt Circle U	Thread Size V	Min. Thread Depth Z
<b>CLSG-50</b>	65	2x M12	22
<b>CLSG-100</b>	95	2x M12	22
<b>CLSG-150</b>	130	2x M12	22
<b>CLSG-200</b>	165	3x M12	22
<b>CLSG-250</b>	190	3x M12	22
<b>CLSG-300</b>	180	3x M16	30
<b>CLSG-400</b>	205	3x M16	30
<b>CLSG-500</b>	250	3x M24	36
<b>CLSG-600</b>	275	3x M24	36
<b>CLSG-800</b>	330	3x M24	36
<b>CLSG-1000</b>	375	3x M24	36

<sup>1)</sup> Base mounting holes are random positioned in regard to coupler position.

# Single-Acting, High Tonnage Cylinders

## Optional Tilt Saddle \*

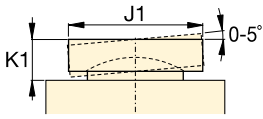

Capacity:  
**50 - 1000 ton**

Stroke:  
**50 - 300 mm**

Maximum Operating Pressure:  
**700 bar**

## CLSG Series



Collapsed Height	Extended Height	Outside Dia.	Cylinder Bore Dia.	Plunger Dia.	Base to Adv. Port H	Standard Saddle Dia. J	Saddle Protr. from Plgr. K	Depth of Plunger Hole L	🏋️ (kg)	Model Number	* Optional Tilt Saddle		
											Saddle Dia. J1 (mm)	Saddle Height K1 (mm)	Saddle Model Number
A (mm)	B (mm)	D (mm)	E (mm)	F (mm)	H (mm)	J (mm)	K (mm)	L (mm)			J1 (mm)	K1 (mm)	Model Number
162	212	130	99,0	70,0	52	50	1	19	17	<b>CLSG-502</b>	50	24	<b>CATG-50</b>
212	312	130	99,0	70,0	52	50	1	19	20	<b>CLSG-504</b>	50	24	<b>CATG-50</b>
262	412	130	99,0	70,0	52	50	1	19	23	<b>CLSG-506</b>	50	24	<b>CATG-50</b>
312	512	130	99,0	70,0	52	50	1	19	27	<b>CLSG-508</b>	50	24	<b>CATG-50</b>
362	612	130	99,0	70,0	52	50	1	19	31	<b>CLSG-5010</b>	50	24	<b>CATG-50</b>
412	712	130	99,0	70,0	52	50	1	19	34	<b>CLSG-5012</b>	50	24	<b>CATG-50</b>
182	232	165	130,0	95,0	54	75	1	19	19	<b>CLSG-1002</b>	73	29	<b>CATG-100</b>
232	332	165	130,0	95,0	54	75	1	19	29	<b>CLSG-1004</b>	73	29	<b>CATG-100</b>
282	432	165	130,0	95,0	54	75	1	19	40	<b>CLSG-1006</b>	73	29	<b>CATG-100</b>
332	532	165	130,0	95,0	54	75	1	19	50	<b>CLSG-1008</b>	73	29	<b>CATG-100</b>
382	632	165	130,0	95,0	54	75	1	19	61	<b>CLSG-10010</b>	73	29	<b>CATG-100</b>
432	732	165	130,0	95,0	54	75	1	19	71	<b>CLSG-10012</b>	73	29	<b>CATG-100</b>
196	246	205	159,0	114,0	61	94	1	19	39	<b>CLSG-1502</b>	91	31	<b>CATG-150</b>
246	346	205	159,0	114,0	61	94	1	19	52	<b>CLSG-1504</b>	91	31	<b>CATG-150</b>
296	446	205	159,0	114,0	61	94	1	19	65	<b>CLSG-1506</b>	91	31	<b>CATG-150</b>
346	546	205	159,0	114,0	61	94	1	19	78	<b>CLSG-1508</b>	91	31	<b>CATG-150</b>
396	646	205	159,0	114,0	61	94	1	19	92	<b>CLSG-15010</b>	91	31	<b>CATG-150</b>
446	746	205	159,0	114,0	61	94	1	19	105	<b>CLSG-15012</b>	91	31	<b>CATG-150</b>
216	266	235	184,0	133,0	67	113	1	24	55	<b>CLSG-2002</b>	118	35	<b>CATG-200</b>
316	466	235	184,0	133,0	67	113	1	24	91	<b>CLSG-2006</b>	118	35	<b>CATG-200</b>
466	766	235	184,0	133,0	67	113	1	24	146	<b>CLSG-20012</b>	118	35	<b>CATG-200</b>
235	285	275	216,0	165,0	73	145	1	24	102	<b>CLSG-2502</b>	144	46	<b>CATG-250</b>
335	485	275	216,0	165,0	73	145	1	24	136	<b>CLSG-2506</b>	144	46	<b>CATG-250</b>
485	785	275	216,0	165,0	73	145	1	24	207	<b>CLSG-25012</b>	144	46	<b>CATG-250</b>
312	362	310	241,0	197,0	101	177	1	19	184	<b>CLSG-3002</b>	160	62	<b>CATG-300</b>
412	562	310	241,0	197,0	101	177	1	19	232	<b>CLSG-3006</b>	160	62	<b>CATG-300</b>
562	862	310	241,0	197,0	101	177	1	19	303	<b>CLSG-30012</b>	160	62	<b>CATG-300</b>
375	425	350	267,0	216,0	114	196	3	27	270	<b>CLSG-4002</b>	193	51	<b>CATG-400</b>
475	625	350	267,0	216,0	114	196	3	27	330	<b>CLSG-4006</b>	193	51	<b>CATG-400</b>
625	925	350	267,0	216,0	114	196	3	27	421	<b>CLSG-40012</b>	193	51	<b>CATG-400</b>
419	469	400	305,0	248,0	114	228	3	27	401	<b>CLSG-5002</b>	228	63	<b>CATG-500</b>
519	669	400	305,0	248,0	114	228	3	27	480	<b>CLSG-5006</b>	228	63	<b>CATG-500</b>
669	969	400	305,0	248,0	114	228	3	27	599	<b>CLSG-50012</b>	228	63	<b>CATG-500</b>
429	479	430	330,0	267,0	114	247	3	27	474	<b>CLSG-6002</b>	241	76	<b>CATG-600</b>
529	679	430	330,0	267,0	114	247	3	27	565	<b>CLSG-6006</b>	241	76	<b>CATG-600</b>
679	979	430	330,0	267,0	114	247	3	27	701	<b>CLSG-60012</b>	241	76	<b>CATG-600</b>
474	524	505	387,0	317,0	149	297	3	27	741	<b>CLSG-8002</b>	287	75	<b>CATG-800</b>
574	724	505	387,0	317,0	149	297	3	27	880	<b>CLSG-8006</b>	287	75	<b>CATG-800</b>
724	1024	505	387,0	317,0	149	297	3	27	1058	<b>CLSG-80012</b>	287	75	<b>CATG-800</b>
564	614	560	432,0	343,0	174	323	3	27	1062	<b>CLSG-10002</b>	311	93	<b>CATG-1000</b>
664	814	560	432,0	343,0	174	323	3	27	1213	<b>CLSG-10006</b>	311	93	<b>CATG-1000</b>
814	1114	560	432,0	343,0	174	323	3	27	1439	<b>CLSG-100012</b>	311	93	<b>CATG-1000</b>

▼ Shown from left to right: CLS-1002, CLS-506, CLS-502



- Lowest collapsed height for use in confined spaces
- Overflow port functions as a stroke limiter
- Plunger wiper reduces contamination, extending cylinder life
- Interchangeable, hardened grooved saddles are standard
- Special synthetic coating for improved corrosion resistance and lower friction for smoother operation
- CR-400 coupler and dust cap included on all models
- Single-acting, load return.

▼ CLS-cylinders doing their job, synchronised lifting a complete fly-over for exact positioning.



## The Single-Acting Heavy Lifting Solution With Reduced Collapsed Height



### Saddles

All CLS cylinders are equipped with bolt-on removable grooved saddles. For information on optional tilt saddles, see selection chart.

Page: **43**



### Gauges

Minimize the risk of overloading and ensure long, dependable service from your equipment. Refer to the System Components Section for a full range of gauges.

Page: **118**



### Remote Lifting

For heavy lifting in remote locations use the Enerpac Z-Class electric pumps.

Page: **84**



### Low Height - High Tonnage

When low height with high force is required, **CLP-Series** Pancake Cylinders with locknut offer the solution to lift the first few centimetres.

Page: **20**



### Synchronous Lifting Systems

The solution for multiple lift point capabilities from 4 to 64 points.

Page: **224**

# Single-Acting, High Tonnage Cylinders

## ▼ QUICK SELECTION CHART

For complete technical information see next page.

Cylinder Capacity	Stroke	Model Number	Cylinder Effective Area	Oil Capacity	Collapsed Height	
ton (kN)	(mm)		(cm <sup>2</sup> )	(cm <sup>3</sup> )	(mm)	(kg)
<b>50</b> (496)	50	<b>CLS-502</b>	70,9	355	128	14
	100	<b>CLS-504</b>	70,9	709	178	18
	150	<b>CLS-506</b>	70,9	1064	228	23
	200	<b>CLS-508</b>	70,9	1418	278	28
	250	<b>CLS-5010</b>	70,9	1773	327	33
	300	<b>CLS-5012</b>	70,9	2127	378	38
<b>100</b> (929)	50	<b>CLS-1002</b>	132,7	664	143	24
	100	<b>CLS-1004</b>	132,7	1327	193	32
	150	<b>CLS-1006</b>	132,7	1991	243	40
	200	<b>CLS-1008</b>	132,7	2654	293	49
	250	<b>CLS-10010</b>	132,7	3318	343	58
	300	<b>CLS-10012</b>	132,7	3981	392	66
<b>150</b> (1390)	50	<b>CLS-1502</b>	198,6	993	165	43
	100	<b>CLS-1504</b>	198,6	1986	215	55
	150	<b>CLS-1506</b>	198,6	2979	265	69
	200	<b>CLS-1508</b>	198,6	3972	315	82
	250	<b>CLS-15010</b>	198,6	4965	365	95
	300	<b>CLS-15012</b>	198,6	5958	414	108
<b>200</b> (1859)	50	<b>CLS-2002</b>	265,6	1330	193	66
	150	<b>CLS-2006</b>	265,6	3989	293	101
	300	<b>CLS-20012</b>	265,6	7977	443	154
<b>250</b> (2562)	50	<b>CLS-2502</b>	366,1	1832	193	90
	150	<b>CLS-2506</b>	366,1	5496	293	137
	300	<b>CLS-25012</b>	366,1	10996	443	208
<b>300</b> (3193)	50	<b>CLS-3002</b>	456,2	2281	235	137
	150	<b>CLS-3006</b>	456,2	6843	335	198
	300	<b>CLS-30012</b>	456,2	13710	485	288
<b>400</b> (3919)	50	<b>CLS-4002</b>	559,9	2800	265	200
	150	<b>CLS-4006</b>	559,9	8399	365	275
	300	<b>CLS-40012</b>	559,9	16770	515	390
<b>500</b> (5118)	50	<b>CLS-5002</b>	731,1	3656	295	289
	150	<b>CLS-5006</b>	731,1	10967	395	390
	300	<b>CLS-50012</b>	731,1	21900	545	540
<b>600</b> (5983)	50	<b>CLS-6002</b>	854,8	4277	310	350
	150	<b>CLS-6006</b>	854,8	12830	410	465
	300	<b>CLS-60012</b>	854,8	25710	560	640
<b>800</b> (8238)	50	<b>CLS-8002</b>	1176,9	5882	355	549
	150	<b>CLS-8006</b>	1176,9	17645	455	709
	300	<b>CLS-80012</b>	1176,9	35370	605	950
<b>1000</b> (10260)	50	<b>CLS-10002</b>	1466,4	7329	385	729
	150	<b>CLS-10006</b>	1466,4	21986	485	921
	300	<b>CLS-100012</b>	1466,4	43950	635	1210

## CLS Series



Capacity:

**50 - 1000 ton**

Stroke:

**50 - 300 mm**

Maximum Operating Pressure:

**700 bar**



### Higher Capacities

1500 and 2000 ton models are available on request.

### Additional Stroke Lengths

Models above 150 ton are also available with standard stroke lengths of 100, 200 and 250 mm. Please contact Enerpac for ordering information.



### Lifting an Unbalanced Load?

See our 'Yellow Pages' for multi-cylinder set-ups.

Page: **245**



### Optional features

To add optional features to your cylinders, add the following suffix to the end of the model number.

Spring return

**E001**

Example:

- For CLS-5006 cylinder with spring return, order: **CLS-5006E001**

Technical specifications for these features are available from Enerpac.



# CLS-Series, High Tonnage Cylinders

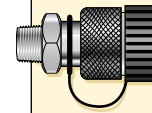

**Couplers Included!**

CR-400 couplers included on all models. Fit all HC-Series hoses.

◀ For full features see previous page.

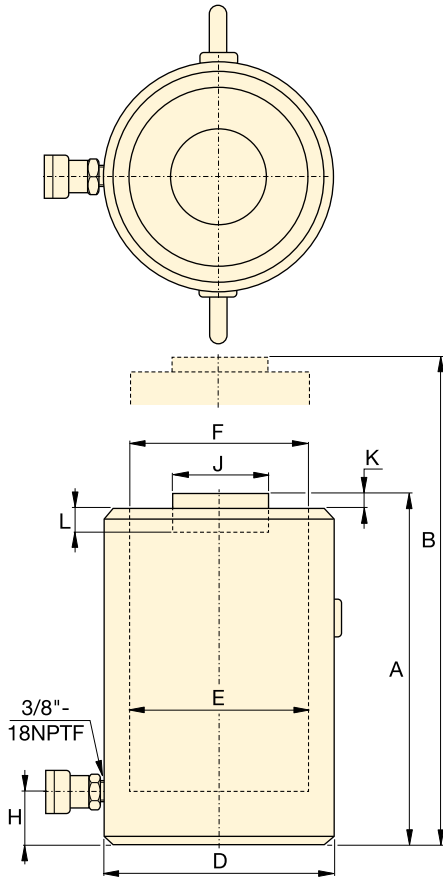

CLS-502 - CLS-25012

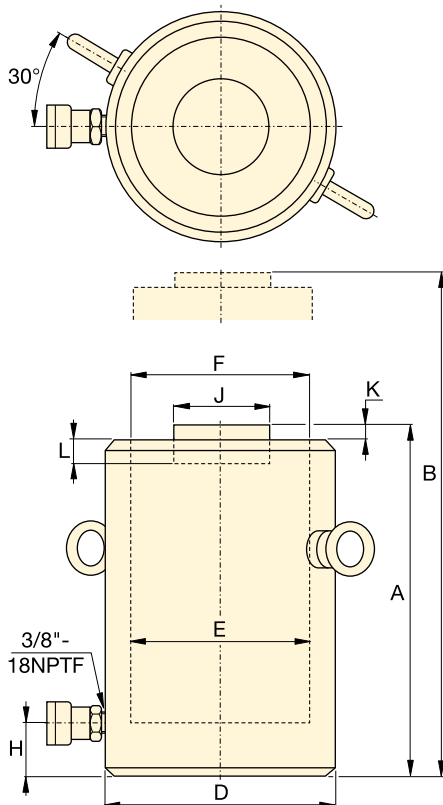

CLS-3002 - CLS-100012

Cylinder Capacity	Stroke	Model Number	Cylinder Effective Area	Oil Capacity
ton (kN)	(mm)		(cm <sup>2</sup> )	(cm <sup>3</sup> )
<b>50</b> (496)	50	<b>CLS-502</b>	70,9	355
	100	<b>CLS-504</b>	70,9	709
	150	<b>CLS-506</b>	70,9	1064
	200	<b>CLS-508</b>	70,9	1418
	250	<b>CLS-5010</b>	70,9	1773
	300	<b>CLS-5012</b>	70,9	2127
<b>100</b> (929)	50	<b>CLS-1002</b>	132,7	664
	100	<b>CLS-1004</b>	132,7	1327
	150	<b>CLS-1006</b>	132,7	1991
	200	<b>CLS-1008</b>	132,7	2654
	250	<b>CLS-10010</b>	132,7	3318
	300	<b>CLS-10012</b>	132,7	3981
<b>150</b> (1390)	50	<b>CLS-1502</b>	198,6	993
	100	<b>CLS-1504</b>	198,6	1986
	150	<b>CLS-1506</b>	198,6	2979
	200	<b>CLS-1508</b>	198,6	3972
	250	<b>CLS-15010</b>	198,6	4965
	300	<b>CLS-15012</b>	198,6	5958
<b>200</b> (1859)	50	<b>CLS-2002</b>	265,6	1330
	150	<b>CLS-2006</b>	265,6	3989
	300	<b>CLS-20012</b>	265,6	7977
<b>250</b> (2562)	50	<b>CLS-2502</b>	366,1	1832
	150	<b>CLS-2506</b>	366,1	5496
	300	<b>CLS-25012</b>	366,1	10996
<b>300</b> (3193)	50	<b>CLS-3002</b>	456,2	2281
	150	<b>CLS-3006</b>	456,2	6843
	300	<b>CLS-30012</b>	456,2	13710
<b>400</b> (3919)	50	<b>CLS-4002</b>	559,9	2800
	150	<b>CLS-4006</b>	559,9	8399
	300	<b>CLS-40012</b>	559,9	16770
<b>500</b> (5118)	50	<b>CLS-5002</b>	731,1	3656
	150	<b>CLS-5006</b>	731,1	10967
	300	<b>CLS-50012</b>	731,1	21900
<b>600</b> (5983)	50	<b>CLS-6002</b>	854,8	4277
	150	<b>CLS-6006</b>	854,8	12830
	300	<b>CLS-60012</b>	854,8	25710
<b>800</b> (8238)	50	<b>CLS-8002</b>	1176,9	5882
	150	<b>CLS-8006</b>	1176,9	17645
	300	<b>CLS-80012</b>	1176,9	35370
<b>1000</b> (10260)	50	<b>CLS-10002</b>	1466,4	7329
	150	<b>CLS-10006</b>	1466,4	21986
	300	<b>CLS-100012</b>	1466,4	43950

# Single-Acting, High Tonnage Cylinders

## Optional Tilt Saddle \*

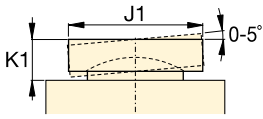

Capacity:  
**50 - 1000 ton**

Stroke:  
**50 - 300 mm**

Maximum Operating Pressure:  
**700 bar**

## CLS Series



Collapsed Height	Extended Height	Outside Dia.	Cylinder Bore Dia.	Plunger Dia.	Base to Adv. Port H	Standard Saddle Dia.	Saddle Protr. from Plgr. K	Depth of Plunger Hole L	🏋️ (kg)	Model Number	* Optional Tilt Saddle		
											Saddle Dia. J1 (mm)	Saddle Height K1 (mm)	Saddle Model Number
A (mm)	B (mm)	D (mm)	E (mm)	F (mm)	H (mm)	J (mm)	K (mm)	L (mm)			J1 (mm)	K1 (mm)	
128	178	125	95,0	95,0	30	71	2	13	14	CLS-502	71	24	CAT-100
178	278	125	95,0	95,0	30	71	2	13	18	CLS-504	71	24	CAT-100
228	378	125	95,0	95,0	30	71	2	13	23	CLS-506	71	24	CAT-100
278	478	125	95,0	95,0	30	71	2	13	28	CLS-508	71	24	CAT-100
327	578	125	95,0	95,0	30	71	2	13	33	CLS-5010	71	24	CAT-100
378	678	125	95,0	95,0	30	71	2	13	38	CLS-5012	71	24	CAT-100
143	193	165	130,0	130,0	30	71	2	13	24	CLS-1002	71	24	CAT-100
193	293	165	130,0	130,0	30	71	2	13	32	CLS-1004	71	24	CAT-100
243	393	165	130,0	130,0	30	71	2	13	40	CLS-1006	71	24	CAT-100
293	493	165	130,0	130,0	30	71	2	13	49	CLS-1008	71	24	CAT-100
343	593	165	130,0	130,0	30	71	2	13	58	CLS-10010	71	24	CAT-100
392	693	165	130,0	130,0	30	71	2	13	66	CLS-10012	71	24	CAT-100
165	215	205	159,0	159,0	39	130	2	25	43	CLS-1502	130	20	CAT-200
215	315	205	159,0	159,0	39	130	2	25	55	CLS-1504	130	20	CAT-200
265	415	205	159,0	159,0	39	130	2	25	69	CLS-1506	130	20	CAT-200
315	515	205	159,0	159,0	39	130	2	25	82	CLS-1508	130	20	CAT-200
365	615	205	159,0	159,0	39	130	2	25	95	CLS-15010	130	20	CAT-200
414	715	205	159,0	159,0	39	130	2	25	108	CLS-15012	130	20	CAT-200
193	243	235	183,9	183,9	50	130	2	25	66	CLS-2002	130	20	CAT-200
293	443	235	183,9	183,9	50	130	2	25	101	CLS-2006	130	20	CAT-200
443	743	235	183,9	183,9	50	130	2	25	154	CLS-20012	130	20	CAT-200
193	243	275	215,9	215,9	50	150	2	25	90	CLS-2502	150	21	CAT-250
293	443	275	215,9	215,9	50	150	2	25	137	CLS-2506	150	21	CAT-250
443	743	275	215,9	215,9	50	150	2	25	208	CLS-25012	150	21	CAT-250
235	285	310	241,0	241,0	59	139	5	25	137	CLS-3002	195	75	CAT-300
335	485	310	241,0	241,0	59	139	5	25	198	CLS-3006	195	75	CAT-300
485	785	310	241,0	241,0	59	139	5	25	288	CLS-30012	195	75	CAT-300
265	315	350	267,0	267,0	70	159	5	25	200	CLS-4002	225	85	CAT-400
365	515	350	267,0	267,0	70	159	5	25	275	CLS-4006	225	85	CAT-400
515	815	350	267,0	267,0	70	159	5	25	390	CLS-40012	225	85	CAT-400
295	345	400	305,1	305,1	80	179	5	25	289	CLS-5002	250	91	CAT-500
395	545	400	305,1	305,1	80	179	5	25	390	CLS-5006	250	91	CAT-500
545	845	400	305,1	305,1	80	179	5	25	540	CLS-50012	250	91	CAT-500
310	360	430	329,9	329,9	85	194	5	25	350	CLS-6002	275	96	CAT-600
410	560	430	329,9	329,9	85	194	5	25	465	CLS-6006	275	96	CAT-600
560	860	430	329,9	329,9	85	194	5	25	640	CLS-60012	275	96	CAT-600
355	405	505	387,1	387,1	100	224	5	25	549	CLS-8002	320	123	CAT-800
455	605	505	387,1	387,1	100	224	5	25	709	CLS-8006	320	123	CAT-800
605	905	505	387,1	387,1	100	224	5	25	950	CLS-80012	320	123	CAT-800
385	435	560	432,1	432,1	110	249	5	25	729	CLS-10002	360	136	CAT-1000
485	635	560	432,1	432,1	110	249	5	25	921	CLS-10006	360	136	CAT-1000
635	935	560	432,1	432,1	110	249	5	25	1210	CLS-100012	360	136	CAT-1000

# CLRG-Series, High Tonnage Cylinders

▼ Shown from left to right: CLRG-506, CLRG-5006, CLRG-4006



- Double-acting, for positive retraction
- Integral stop ring provides piston blow-out protection
- Safety valve in retract side of cylinder helps to prevent damage in case of accidental over-pressurization
- Plunger wiper reduces contamination, extending cylinder life
- CR-400 coupler and dust cap included on all models
- Baked enamel finish and plated pistons provide superior corrosion resistance.

▼ *The dismantling of the temporary support towers of Beijing's "Bird's Nest". During the stage lowering process the bird's nest is alternatively supported by CLRG-Series cylinders.*



## Double-Acting Power Lifters



### Saddles

All CLRG cylinders are equipped with bolt-on removable grooved saddles. For information on optional tilt saddles, see selection chart.

Page: **47**



### Safety Device

A pilot-operated check valve (**V-42**) can be inserted between cylinder and pump. This valve provides a safety

lock on the cylinder under load at any position and remote control for unlocking.

Page: **134**



### Optimum Performance

Enerpac's range of ZU4-Series electric pumps, fitted with manual or solenoid operated 4-way valves, offer optimum combinations

with CLRG cylinders.

Page: **84**



### Standard Features

- Interchangeable, hardened grooved saddles
  - Top and side mounted lifting eyes
  - CR-400 coupler and dustcap
  - All cylinders meet ASME B-30.1 and ISO 10100 standards.

▼ *Replacing adjustment rolls under a fly-over with CLRG cylinders, for controlled lifting and lowering.*



# Double-Acting, High Tonnage Cylinders



## RR-series

For higher cycle applications Enerpac RR-Series cylinders are a good alternative.

Page: **32**

## ▼ QUICK SELECTION CHART

For complete technical information see next page.

Cylinder Capacity ton (kN)	Stroke (mm)	Model Number	Cylinder Effective Area (cm <sup>2</sup> )		Oil Capacity (cm <sup>3</sup> )		Collapsed Height (mm)
			Push	Pull	Push	Pull	
50 (539)	50	CLRG-502	77,0	38,5	385	192	162
	100	CLRG-504	77,0	38,5	770	385	212
	150	CLRG-506	77,0	38,5	1155	577	262
	200	CLRG-508	77,0	38,5	1540	770	312
	250	CLRG-5010	77,0	38,5	1924	962	362
	300	CLRG-5012	77,0	38,5	2309	1155	412
100 (929)	50	CLRG-1002	132,7	61,9	664	309	179
	100	CLRG-1004	132,7	61,9	1327	619	229
	150	CLRG-1006	132,7	61,9	1991	928	279
	200	CLRG-1008	132,7	61,9	2655	1237	329
	250	CLRG-10010	132,7	61,9	3318	1546	379
	300	CLRG-10012	132,7	61,9	3982	1856	429
150 (1390)	50	CLRG-1502	198,6	96,5	993	482	196
	100	CLRG-1504	198,6	96,5	1986	965	246
	150	CLRG-1506	198,6	96,5	2978	1447	296
	200	CLRG-1508	198,6	96,5	3971	1930	346
	250	CLRG-15010	198,6	96,5	4964	2412	396
	300	CLRG-15012	198,6	96,5	5957	2895	446
200 (1861)	50	CLRG-2002	265,9	127,0	1330	635	212
	150	CLRG-2006	265,9	127,0	3989	1905	312
	300	CLRG-20012	265,9	127,0	7977	3809	462
250 (2565)	50	CLRG-2502	366,4	152,6	1832	763	235
	150	CLRG-2506	366,4	152,6	5497	2289	335
	300	CLRG-25012	366,4	152,6	10993	4578	485
300 (3193)	50	CLRG-3002	456,2	151,4	2281	757	322
	150	CLRG-3006	456,2	151,4	6843	2270	422
	300	CLRG-30012	456,2	151,4	13685	4541	572
400 (3919)	50	CLRG-4002	559,9	193,5	2800	967	374
	150	CLRG-4006	559,9	193,5	8399	2902	474
	300	CLRG-40012	559,9	193,5	16797	5804	624
500 (5114)	50	CLRG-5002	730,6	247,6	3653	1238	419
	150	CLRG-5006	730,6	247,6	10959	3713	519
	300	CLRG-50012	730,6	247,6	21918	7427	669
600 (5987)	50	CLRG-6002	855,3	295,4	4276	1477	429
	150	CLRG-6006	855,3	295,4	12829	4431	529
	300	CLRG-60012	855,3	295,4	25659	8862	679
800 (8234)	50	CLRG-8002	1176,3	387,0	5881	1935	484
	150	CLRG-8006	1176,3	387,0	17644	5806	584
	300	CLRG-80012	1176,3	387,0	35288	11611	734
1000 (10260)	50	CLRG-10002	1465,7	541,7	7329	2709	564
	150	CLRG-10006	1465,7	541,7	21986	8126	664
	300	CLRG-100012	1465,7	541,7	43972	16252	814

## CLRG Series



Capacity:

**50 - 1000 ton**

Stroke:

**50 - 300 mm**

Maximum Operating Pressure:

**700 bar**



### Pump Selection

A double-acting cylinder must be powered by a pump with a 4-way valve.

Page: **84**



### Higher Capacities

1500 and 2000 ton models are available on request.

### Additional Stroke Lengths

Models above 150 ton are also available with standard stroke lengths of 100, 200 and 250 mm. Please contact Enerpac for ordering information.



### Optional features

To add optional features to your cylinders, add the following suffixes to the end of the model number.

Collar thread *	<b>E002</b>
Plunger thread	<b>E003</b>
Collar * and plunger thread	<b>E005</b>

\* On 400 ton and higher

Example:

- For CLRG-5006 cylinder with collar thread, order: **CLRG-5006E002**

Technical specifications for these features are available from Enerpac.



# CLRG-Series, High Tonnage Cylinders



### Mounting Hole Orientation

Top mounting hole orientation is maintained to port location. Base mounting hole orientation is not maintained to port location.

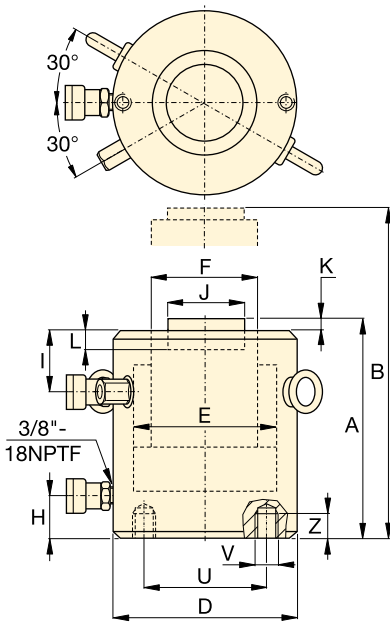

CLRG-502 - CLRG-15012

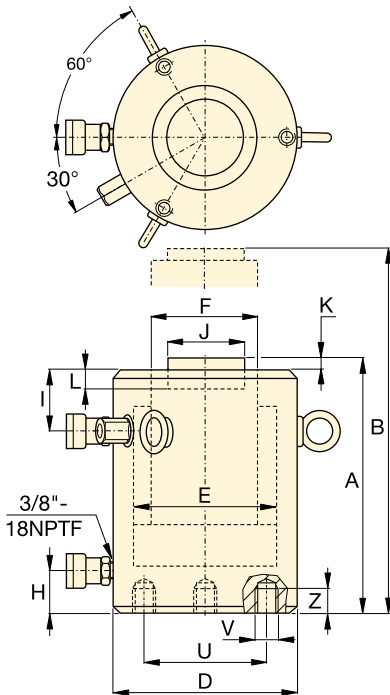

CLRG-2002 - CLRG-100012

Base Mounting Hole <sup>1)</sup> Dimensions (mm)			
Model / Capacity ton	Bolt Circle U	Thread Size V	Min. Thread Depth Z
CLRG-50	65	2x M12	22
CLRG-100	95	2x M12	22
CLRG-150	130	2x M12	22
CLRG-200	165	3x M12	22
CLRG-250	190	3x M12	22
CLRG-300	180	3x M16	30
CLRG-400	205	3x M16	30
CLRG-500	250	3x M24	36
CLRG-600	275	3x M24	36
CLRG-800	330	3x M24	36
CLRG-1000	375	3x M24	36

◀ For full features see previous page.

Cylinder Capacity (ton)	Stroke (mm)	Model Number	Maximum Cylinder Capacity (kN)		Cylinder Effective Area (cm <sup>2</sup> )		Oil Capacity (cm <sup>3</sup> )	
			Push	Pull	Push	Pull	Push	Pull
50	50	CLRG-502	539	269	77,0	38,5	385	192
	100	CLRG-504	539	269	77,0	38,5	770	385
	150	CLRG-506	539	269	77,0	38,5	1155	577
	200	CLRG-508	539	269	77,0	38,5	1540	770
	250	CLRG-5010	539	269	77,0	38,5	1924	962
	300	CLRG-5012	539	269	77,0	38,5	2309	1155
100	50	CLRG-1002	929	433	132,7	61,9	664	309
	100	CLRG-1004	929	433	132,7	61,9	1327	619
	150	CLRG-1006	929	433	132,7	61,9	1991	928
	200	CLRG-1008	929	433	132,7	61,9	2655	1237
	250	CLRG-10010	929	433	132,7	61,9	3318	1546
	300	CLRG-10012	929	433	132,7	61,9	3982	1856
150	50	CLRG-1502	1390	675	198,6	96,5	993	482
	100	CLRG-1504	1390	675	198,6	96,5	1986	965
	150	CLRG-1506	1390	675	198,6	96,5	2978	1447
	200	CLRG-1508	1390	675	198,6	96,5	3971	1930
	250	CLRG-15010	1390	675	198,6	96,5	4964	2412
	300	CLRG-15012	1390	675	198,6	96,5	5957	2895
200	50	CLRG-2002	1861	889	265,9	127,0	1330	635
	150	CLRG-2006	1861	889	265,9	127,0	3989	1905
	300	CLRG-20012	1861	889	265,9	127,0	7977	3809
250	50	CLRG-2502	2565	1068	366,4	152,6	1832	763
	150	CLRG-2506	2565	1068	366,4	152,6	5497	2289
	300	CLRG-25012	2565	1068	366,4	152,6	10993	4578
300	50	CLRG-3002	3193	1060	456,2	151,4	2281	757
	150	CLRG-3006	3193	1060	456,2	151,4	6843	2270
	300	CLRG-30012	3193	1060	456,2	151,4	13685	4541
400	50	CLRG-4002	3919	1354	559,9	193,5	2800	967
	150	CLRG-4006	3919	1354	559,9	193,5	8399	2902
	300	CLRG-40012	3919	1354	559,9	193,5	16797	5804
500	50	CLRG-5002	5114	1733	730,6	247,6	3653	1238
	150	CLRG-5006	5114	1733	730,6	247,6	10959	3713
	300	CLRG-50012	5114	1733	730,6	247,6	21918	7427
600	50	CLRG-6002	5987	2068	855,3	295,4	4276	1477
	150	CLRG-6006	5987	2068	855,3	295,4	12829	4431
800	50	CLRG-8002	8234	2709	1176,3	387,0	5881	1935
	150	CLRG-8006	8234	2709	1176,3	387,0	17644	5806
1000	50	CLRG-10002	10260	3792	1465,7	541,7	7329	2709
	150	CLRG-10006	10260	3792	1465,7	541,7	21986	8126
	300	CLRG-100012	10260	3792	1465,7	541,7	43972	16252

<sup>1)</sup> Base mounting holes are random positioned in regard to coupler position.

# Double-Acting, High Tonnage Cylinders

## \* Optional Tilt Saddle

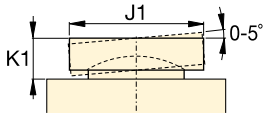

Capacity:

**50 - 1000 ton**

Stroke:

**50 - 300 mm**

Maximum Operating Pressure:

**700 bar**

## CLRG Series



Collaps. Height	Extend. Height	Outside Dia.	Cyl. Bore Dia. E (mm)	Plunger Dia. F (mm)	Base to Advance Port H (mm)	Top to Retract Port I (mm)	Standard Saddle Dia. J (mm)	Saddle Protr. from Plgr. K (mm)	Depth of Plunger Hole L (mm)	Weight (kg)	Model Number	Optional Tilt Saddle *		
												Saddle Dia. J1 (mm)	Saddle Height K1 (mm)	Saddle Model Number
162	212	130	99	70	52	33	50	1	19	17	CLRG-502	50	24	CATG-50
212	312	130	99	70	52	33	50	1	19	20	CLRG-504	50	24	CATG-50
262	412	130	99	70	52	33	50	1	19	23	CLRG-506	50	24	CATG-50
312	512	130	99	70	52	33	50	1	19	27	CLRG-508	50	24	CATG-50
362	612	130	99	70	52	33	50	1	19	31	CLRG-5010	50	24	CATG-50
412	712	130	99	70	52	33	50	1	19	34	CLRG-5012	50	24	CATG-50
179	229	165	130	95	54	48	75	1	19	29	CLRG-1002	73	29	CATG-100
229	329	165	130	95	54	48	75	1	19	34	CLRG-1004	73	29	CATG-100
279	429	165	130	95	54	48	75	1	19	40	CLRG-1006	73	29	CATG-100
329	529	165	130	95	54	48	75	1	19	46	CLRG-1008	73	29	CATG-100
379	629	165	130	95	54	48	75	1	19	52	CLRG-10010	73	29	CATG-100
429	729	165	130	95	54	48	75	1	19	58	CLRG-10012	73	29	CATG-100
196	246	205	159	114	61	56	94	1	19	39	CLRG-1502	91	31	CATG-150
246	346	205	159	114	61	56	94	1	19	52	CLRG-1504	91	31	CATG-150
296	446	205	159	114	61	56	94	1	19	65	CLRG-1506	91	31	CATG-150
346	546	205	159	114	61	56	94	1	19	78	CLRG-1508	91	31	CATG-150
396	646	205	159	114	61	56	94	1	19	92	CLRG-15010	91	31	CATG-150
446	746	205	159	114	61	56	94	1	19	105	CLRG-15012	91	31	CATG-150
212	262	235	184	133	67	66	113	1	24	55	CLRG-2002	118	35	CATG-200
312	462	235	184	133	67	66	113	1	24	91	CLRG-2006	118	35	CATG-200
462	762	235	184	133	67	66	113	1	24	146	CLRG-20012	118	35	CATG-200
235	285	275	216	165	73	78	145	1	24	89	CLRG-2502	144	46	CATG-250
335	485	275	216	165	73	78	145	1	24	136	CLRG-2506	144	46	CATG-250
485	785	275	216	165	73	78	145	1	24	207	CLRG-25012	144	46	CATG-250
322	372	310	241	197	101	75	177	1	19	184	CLRG-3002	160	62	CATG-300
422	572	310	241	197	101	75	177	1	19	232	CLRG-3006	160	62	CATG-300
572	872	310	241	197	101	75	177	1	19	303	CLRG-30012	160	62	CATG-300
374	424	350	267	216	114	105	196	3	27	270	CLRG-4002	193	51	CATG-400
474	624	350	267	216	114	105	196	3	27	330	CLRG-4006	193	51	CATG-400
624	924	350	267	216	114	105	196	3	27	421	CLRG-40012	193	51	CATG-400
419	469	400	305	248	114	135	228	3	27	401	CLRG-5002	228	63	CATG-500
519	669	400	305	248	114	135	228	3	27	480	CLRG-5006	228	63	CATG-500
669	969	400	305	248	114	135	228	3	27	599	CLRG-50012	228	63	CATG-500
429	479	430	330	267	114	135	247	3	27	474	CLRG-6002	241	76	CATG-600
529	679	430	330	267	114	135	247	3	27	565	CLRG-6006	241	76	CATG-600
679	979	430	330	267	114	135	247	3	27	701	CLRG-60012	241	76	CATG-600
484	534	505	387	317	149	135	297	3	27	741	CLRG-8002	287	75	CATG-800
584	734	505	387	317	149	135	297	3	27	868	CLRG-8006	287	75	CATG-800
734	1034	505	387	317	149	135	297	3	27	1058	CLRG-80012	287	75	CATG-800
564	614	560	432	343	174	170	323	3	27	1062	CLRG-10002	311	93	CATG-1000
664	814	560	432	343	174	170	323	3	27	1213	CLRG-10006	311	93	CATG-1000
814	1114	560	432	343	174	170	323	3	27	1439	CLRG-100012	311	93	CATG-1000

# CLL-Series, Lock Nut Cylinders

▼ Shown from left to right: CLL-5010, CLL-502, CLL-1006



- **Single-acting, load return**
- **Safety Lock Nut for mechanical load holding**
- **Special synthetic coating for improved corrosion resistance and lower friction for smoother operation**
- **Overflow port functions as a stroke limiter**
- **Interchangeable, hardened grooved saddles are standard**
- **CR-400 coupler and dust cap included on all models.**

▼ For this curved bridge, CLL-cylinders were used to support the concrete beams, to level the pierhead and to place 4000 ton slide bearings between pier and pierhead.



## To Secure Loads Mechanically



### Saddles

All CLL cylinders are equipped with bolt-on removable grooved saddles. For information on optional

tilt saddles, see selection chart at next page.

Page: 51



### Gauges

Minimize the risk of overloading and ensure long, dependable service from your equipment. Refer to the

System Components Section for a full range of gauges.

Page: 118



### Low Height - High Tonnage

When low height with high force is required, Pancake Cylinders with lock nut offer the solution to lift the first few centimetres.

Page: 20

▼ CLL cylinder, mechanically locked, after positioning the curved bridge.



# Single-Acting, Lock Nut Cylinders

## ▼ QUICK SELECTION CHART

For complete technical information see next page.

Cylinder Capacity	Stroke	Model Number	Cylinder Effective Area	Oil Capacity	Collapsed Height	
ton (kN)	(mm)		(cm <sup>2</sup> )	(cm <sup>3</sup> )	(mm)	(kg)
<b>50</b> (496)	50	<b>CLL-502</b>	70,9	355	164	15
	100	<b>CLL-504</b>	70,9	709	214	20
	150	<b>CLL-506</b>	70,9	1064	264	25
	200	<b>CLL-508</b>	70,9	1418	314	30
	250	<b>CLL-5010</b>	70,9	1773	364	35
	300	<b>CLL-5012</b>	70,9	2127	414	40
<b>100</b> (929)	50	<b>CLL-1002</b>	132,7	664	187	30
	100	<b>CLL-1004</b>	132,7	1327	237	39
	150	<b>CLL-1006</b>	132,7	1991	287	48
	200	<b>CLL-1008</b>	132,7	2654	337	56
	250	<b>CLL-10010</b>	132,7	3318	387	64
	300	<b>CLL-10012</b>	132,7	3981	437	73
<b>150</b> (1390)	50	<b>CLL-1502</b>	198,6	993	209	53
	100	<b>CLL-1504</b>	198,6	1986	259	66
	150	<b>CLL-1506</b>	198,6	2979	309	78
	200	<b>CLL-1508</b>	198,6	3972	359	92
	250	<b>CLL-15010</b>	198,6	4965	409	104
	300	<b>CLL-15012</b>	198,6	5958	459	117
<b>200</b> (1859)	50	<b>CLL-2002</b>	265,6	1330	243	83
	150	<b>CLL-2006</b>	265,6	3989	343	117
	300	<b>CLL-20012</b>	265,6	7995	493	170
<b>250</b> (2562)	50	<b>CLL-2502</b>	366,1	1832	249	116
	150	<b>CLL-2506</b>	366,1	5496	349	162
	300	<b>CLL-25012</b>	366,1	10995	499	234
<b>300</b> (3193)	50	<b>CLL-3002</b>	456,2	2281	295	173
	150	<b>CLL-3006</b>	456,2	6843	395	233
	300	<b>CLL-30012</b>	456,2	13740	545	323
<b>400</b> (3919)	50	<b>CLL-4002</b>	559,9	2800	335	250
	150	<b>CLL-4006</b>	559,9	8399	435	327
	300	<b>CLL-40012</b>	559,9	16800	585	441
<b>500</b> (5118)	50	<b>CLL-5002</b>	731,1	3653	375	367
	150	<b>CLL-5006</b>	731,1	10959	475	466
	300	<b>CLL-50012</b>	731,1	21930	625	617
<b>600</b> (5983)	50	<b>CLL-6002</b>	854,8	4277	395	446
	150	<b>CLL-6006</b>	854,8	12830	495	562
	300	<b>CLL-60012</b>	854,8	25650	645	737
<b>800</b> (8238)	50	<b>CLL-8002</b>	1176,9	5882	455	709
	150	<b>CLL-8006</b>	1176,9	17645	555	870
	300	<b>CLL-80012</b>	1176,9	35370	705	1110
<b>1000</b> (10260)	50	<b>CLL-10002</b>	1466,4	7329	495	949
	150	<b>CLL-10006</b>	1466,4	21986	595	1141
	300	<b>CLL-100012</b>	1466,4	43980	745	1430

## CLL Series



Capacity:

**50 - 1000 ton**

Stroke:

**50 - 300 mm**

Maximum Operating Pressure:

**700 bar**



### Higher Capacities

1500 and 2000 ton models are available on request.

### Additional Stroke Lengths

Models above 150 ton are also available with standard stroke lengths of 100, 200 and 250 mm. Please contact Enerpac for ordering information.



### Lifting an Unbalanced Load?

See our 'Yellow Pages' for multi-cylinder set-ups.

Page: **245**



### Speed Chart

See the Cylinder Speed Chart in our 'Yellow Pages' section to determine the approximate cylinder speed.

Page: **249**



### Optional features

To add an optional feature to your cylinders, add the following suffix to the end of the model number.

Spring return

**E001**

Example:

- For CLL-5006 cylinder with spring return, order: **CLL-5006E001**

Technical specifications for these features are available from Enerpac.



# CLL-Series, Lock Nut Cylinders

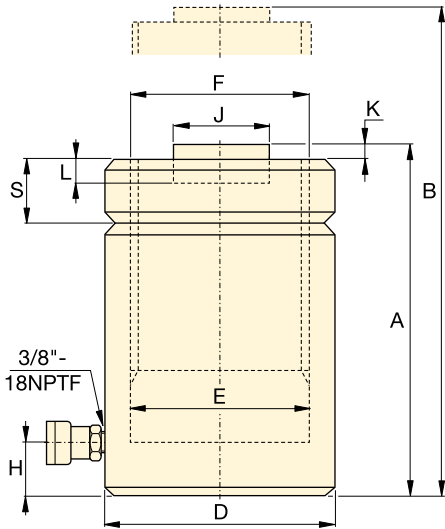
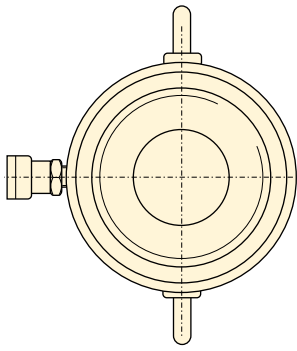

CLL-502 - CLL-25012

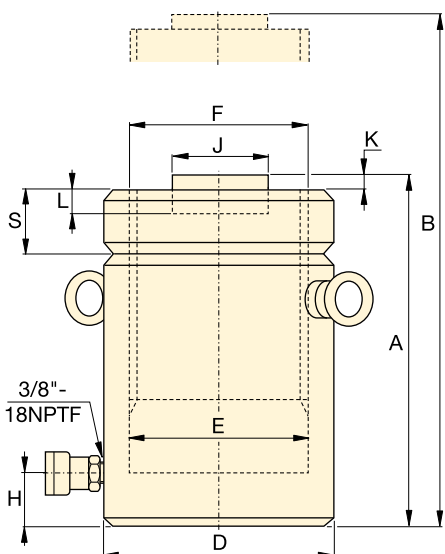
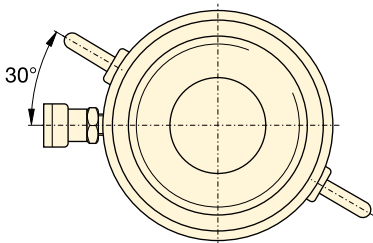

CLL-3002 - CLL-100012

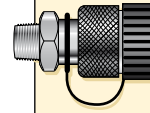

### Couplers Included!

CR-400 couplers included on all models. Fit all HC-Series hoses.

◀ For full features see previous page.

Cylinder Capacity ton (kN)	Stroke (mm)	Model Number	Cylinder Effective Area (cm <sup>2</sup> )	Oil Capacity (cm <sup>3</sup> )
50 (496)	50	CLL-502	70,9	355
	100	CLL-504	70,9	709
	150	CLL-506	70,9	1064
	200	CLL-508	70,9	1418
	250	CLL-5010	70,9	1773
	300	CLL-5012	70,9	2127
100 (929)	50	CLL-1002	132,7	664
	100	CLL-1004	132,7	1327
	150	CLL-1006	132,7	1991
	200	CLL-1008	132,7	2654
	250	CLL-10010	132,7	3318
	300	CLL-10012	132,7	3981
150 (1390)	50	CLL-1502	198,6	993
	100	CLL-1504	198,6	1986
	150	CLL-1506	198,6	2979
	200	CLL-1508	198,6	3972
	250	CLL-15010	198,6	4965
	300	CLL-15012	198,6	5958
200 (1859)	50	CLL-2002	265,6	1330
	150	CLL-2006	265,6	3989
	300	CLL-20012	265,6	7995
250 (2562)	50	CLL-2502	366,1	1832
	150	CLL-2506	366,1	5496
	300	CLL-25012	366,1	10995
300 (3193)	50	CLL-3002	456,2	2281
	150	CLL-3006	456,2	6843
	300	CLL-30012	456,2	13740
400 (3919)	50	CLL-4002	559,9	2800
	150	CLL-4006	559,9	8399
	300	CLL-40012	559,9	16800
500 (5118)	50	CLL-5002	731,1	3653
	150	CLL-5006	731,1	10959
	300	CLL-50012	731,1	21930
600 (5983)	50	CLL-6002	854,8	4277
	150	CLL-6006	854,8	12830
	300	CLL-60012	854,8	25650
800 (8238)	50	CLL-8002	1176,9	5882
	150	CLL-8006	1176,9	17645
	300	CLL-80012	1176,9	35370
1000 (10260)	50	CLL-10002	1466,4	7329
	150	CLL-10006	1466,4	21986
	300	CLL-100012	1466,4	43980

# Single-Acting, Lock Nut Cylinders

## Optional Tilt Saddle \*

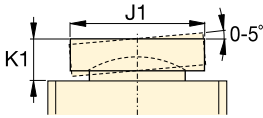

Capacity:

**50 - 1000 ton**

Stroke:

**50 - 300 mm**

Maximum Operating Pressure:

**700 bar**

## CLL Series



Coll. Height A (mm)	Ext. Height B (mm)	Outs. Dia. D (mm)	Cyl. Bore Dia. E (mm)	Plunger Dia. (threaded) F (mm)	Base to Adv. Port H (mm)	Standard Saddle Dia. J (mm)	Saddle Protr. from Plgr. K (mm)	Depth of Plunger Hole L (mm)	Lock-nut Height S (mm)	🏋️ (kg)	Model Number	* Optional Tilt Saddle		
												Saddle Dia. J1 (mm)	Saddle Height K1 (mm)	Saddle Model Number
164	214	125	95,0	Tr 95 x 4	30	71	2	13	36	15	CLL-502	71	24	CAT-100
214	314	125	95,0	Tr 95 x 4	30	71	2	13	36	20	CLL-504	71	24	CAT-100
264	414	125	95,0	Tr 95 x 4	30	71	2	13	36	25	CLL-506	71	24	CAT-100
314	514	125	95,0	Tr 95 x 4	30	71	2	13	36	30	CLL-508	71	24	CAT-100
364	614	125	95,0	Tr 95 x 4	30	71	2	13	36	35	CLL-5010	71	24	CAT-100
414	714	125	95,0	Tr 95 x 4	30	71	2	13	36	40	CLL-5012	71	24	CAT-100
187	237	165	130,0	Tr 130 x 6	30	71	2	13	44	30	CLL-1002	71	24	CAT-100
237	337	165	130,0	Tr 130 x 6	30	71	2	13	44	39	CLL-1004	71	24	CAT-100
287	437	165	130,0	Tr 130 x 6	30	71	2	13	44	48	CLL-1006	71	24	CAT-100
337	537	165	130,0	Tr 130 x 6	30	71	2	13	44	56	CLL-1008	71	24	CAT-100
387	637	165	130,0	Tr 130 x 6	30	71	2	13	44	64	CLL-10010	71	24	CAT-100
437	737	165	130,0	Tr 130 x 6	30	71	2	13	44	73	CLL-10012	71	24	CAT-100
209	259	205	159,0	Tr 159 x 6	39	130	2	25	44	53	CLL-1502	130	20	CAT-200
259	359	205	159,0	Tr 159 x 6	39	130	2	25	44	66	CLL-1504	130	20	CAT-200
309	459	205	159,0	Tr 159 x 6	39	130	2	25	44	78	CLL-1506	130	20	CAT-200
359	559	205	159,0	Tr 159 x 6	39	130	2	25	44	92	CLL-1508	130	20	CAT-200
409	659	205	159,0	Tr 159 x 6	39	130	2	25	44	104	CLL-15010	130	20	CAT-200
459	759	205	159,0	Tr 159 x 6	39	130	2	25	44	117	CLL-15012	130	20	CAT-200
243	293	235	184,0	Tr 184 x 6	50	130	2	25	50	83	CLL-2002	130	20	CAT-200
343	493	235	184,0	Tr 184 x 6	50	130	2	25	50	117	CLL-2006	130	20	CAT-200
493	793	235	184,0	Tr 184 x 6	50	130	2	25	50	170	CLL-20012	130	20	CAT-200
249	299	275	216,0	Tr 216 x 6	50	150	2	25	56	116	CLL-2502	150	21	CAT-250
349	499	275	216,0	Tr 216 x 6	50	150	2	25	56	162	CLL-2506	150	21	CAT-250
499	799	275	216,0	Tr 216 x 6	50	150	2	25	56	234	CLL-25012	150	21	CAT-250
295	345	310	241,0	Tr 241 x 6	59	139	5	25	60	173	CLL-3002	195	75	CAT-300
395	545	310	241,0	Tr 241 x 6	59	139	5	25	60	233	CLL-3006	195	75	CAT-300
545	845	310	241,0	Tr 241 x 6	59	139	5	25	60	323	CLL-30012	195	75	CAT-300
335	385	350	267,0	Tr 266 x 6	70	159	5	25	70	250	CLL-4002	225	85	CAT-400
435	585	350	267,0	Tr 266 x 6	70	159	5	25	70	327	CLL-4006	225	85	CAT-400
585	885	350	267,0	Tr 266 x 6	70	159	5	25	70	441	CLL-40012	225	85	CAT-400
375	425	400	305,0	Tr 305 x 6	80	179	5	25	80	367	CLL-5002	250	91	CAT-500
475	625	400	305,0	Tr 305 x 6	80	179	5	25	80	466	CLL-5006	250	91	CAT-500
625	925	400	305,0	Tr 305 x 6	80	179	5	25	80	617	CLL-50012	250	91	CAT-500
395	445	430	330,0	Tr 330 x 6	85	194	5	25	85	446	CLL-6002	275	96	CAT-600
495	645	430	330,0	Tr 330 x 6	85	194	5	25	85	562	CLL-6006	275	96	CAT-600
645	945	430	330,0	Tr 330 x 6	85	194	5	25	85	737	CLL-60012	275	96	CAT-600
455	505	505	387,0	Tr 387 x 6	100	224	5	25	100	709	CLL-8002	320	123	CAT-800
555	705	505	387,0	Tr 387 x 6	100	224	5	25	100	870	CLL-8006	320	123	CAT-800
705	1005	505	387,0	Tr 387 x 6	100	224	5	25	100	1110	CLL-80012	320	123	CAT-800
495	545	560	432,0	Tr 432 x 6	110	249	5	25	110	949	CLL-10002	360	136	CAT-1000
595	745	560	432,0	Tr 432 x 6	110	249	5	25	110	1141	CLL-10006	360	136	CAT-1000
745	1045	560	432,0	Tr 432 x 6	110	249	5	25	110	1430	CLL-100012	360	136	CAT-1000

▼ LB-28



- Nine sizes with lifting capacities from 3,1 to 67,2 ton Kevlar® reinforced and “center target” marked to assure safety in use
- Aggressive high-friction surface to prevent bags from slipping
- Non-conducting rubber, resists oil and most chemicals; operating temperature range is 0 °C to 90 °C
- 25 ton and larger sizes provided with Nylon® straps and heavy-duty reinforced lugs
- Industrial interchange air supply to deadman controller; safety coupler inflation hoses protect against accidental disconnections
- Inflatable using shop air or water.



◀ Handle close clearance loads with the thinnest profile possible.

## Low clearance lifting using compressed air or water

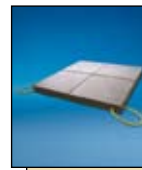

### Lifting Bag Base

Use a 610 x 610 mm lifting bag base under lifting bag to provide a flat surface and protect the lifting bag from debris damage. Order model number **LPC2421**.



### Cribbing Blocks

Safely support lifted loads using Enerpac Resin Cribbing. Available in three sizes and as wedges to help stabilize stacks.

Page: 54



### Low Clearance Loads

Lift up to 16 tons with minimal clearance gap of only 10 mm with **LW-16** Lifting Wedge.

Page: 172

# Lifting Bags

## LB Series



Lifting Bag Capacity:  
**3,1 - 67,2 ton**

Collapsed Height:  
**28-31 mm**

Maximum Extended Height:  
**157-541 mm**

Maximum Operating Air Pressure:  
**8 bar**

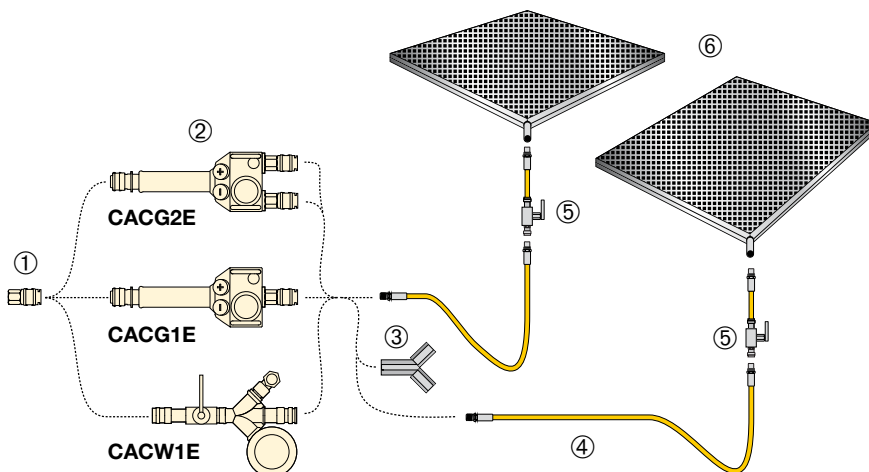

### ▼ SELECTION CHART

Item Nr.	Model Number usage with air	Model Number usage with water	Description
①	CACA1	-	Construction Compressor Adaptor
②	CACG1E	-	Single Deadman Controller
	CACG2E	-	Double Deadman Controller
③	-	CACW1E	Single Ball Valve Controller
	CAYC	CAYC	"Y" Connector for Twin application
④	AY0805	-	Yellow inflation Hose 5 meters
	AY0810	-	Yellow inflation Hose 10 meters
	-	AB0805	Blue inflation Hose 5 meters
	-	AB0810	Blue inflation Hose 10 meters
⑤	A0801	-	Yellow hose 0,5 meter with Pressure Relief Valve and Ball Valve
⑥	LB-3.....LB-74	LB-3.....LB-74	Lifting Bags (see below)

### LIFTING HEIGHT vs. LOAD CHART

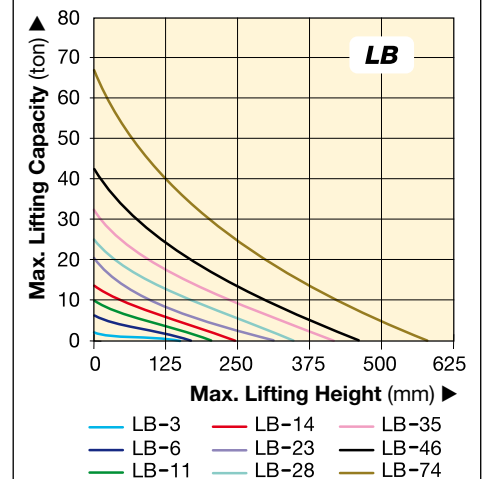

### ▼ SELECTION CHART

*Lifting Bag Capacity	Collapsed Height	Maximum Lifting Height	Maximum Extended Height	Model Number	*Capacity @ 50% Extended Height	Length x Width	Nylon Straps & Lugs Included	
ton (kN)	(mm)	(mm)	(mm)		ton (kN)	(mm)		(kg)
3,1 (27)	28	130	157	LB-3	0,7 (6,8)	229 x 229	-	1,3
5,8 (57)	28	150	178	LB-6	1,7 (16,6)	305 x 305	-	2,4
9,8 (96)	28	180	208	LB-11	3,6 (35,3)	381 x 381	-	4,0
12,9 (126)	28	220	249	LB-14	4,0 (39,2)	457 x 457	-	5,3
20,6 (202)	28	270	297	LB-23	6,4 (62,7)	559 x 559	-	8,1
25,1 (246)	31	300	330	LB-28	7,7 (75,5)	610 x 610	•	11,2
32,0 (314)	31	360	391	LB-35	9,0 (88,2)	686 x 686	•	13,3
42,1 (413)	31	420	449	LB-46	11,7 (114,7)	762 x 762	•	18,4
67,2 (656)	31	510	541	LB-74	19,1 (187,2)	914 x 914	•	25,3

\* Lifting capacity reduces as lifting bag height increases: see diagram.



▼ Shown: LPC6701-B, LPC4401-Y, LPC2401-B, LPC3W-B



## Durable Crib Blocks Safely Support and Stabilize Lifted Loads



### Lifting Bags

Safely lift loads using Enerpac Lifting Bags. Inflatable using compressed air or water.

Page: 52



### Properties

Enerpac resin cribbing blocks can be nailed, screwed or sawn like wood. Piloted ignition is similar to wood.



### Crib Block Capacity

Crib stack may compress up to 50 mm at 21°C with no cracked blocks. Ratings are based on a full press load in which the load is evenly distributed across the crib stack using a 25 mm steel plate to spread the load. Do not load any localized area of a crib or cribbing block at more than 1100 N/cm<sup>2</sup> (1600 psi)

- Multiple sizes, shapes fit most applications
- Interlocking or aggressive non-slip surface
- \*\*Non-conducting plastic resists oil and most chemicals
- Does not splinter, like wood
- Operating temperature range is -40 °C to +80 °C
- Carrying lanyards provided on all 6" x 7" and on yellow 4" x 4" cribbing blocks
- Made from 100% recycled plastics
- Durable crib blocks safely support and stabilize lifted loads.

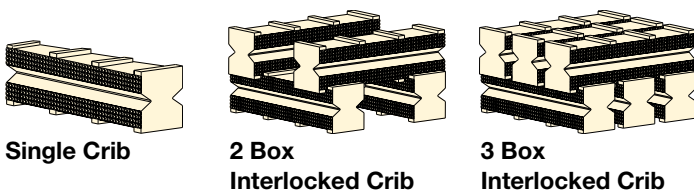

### Application examples:

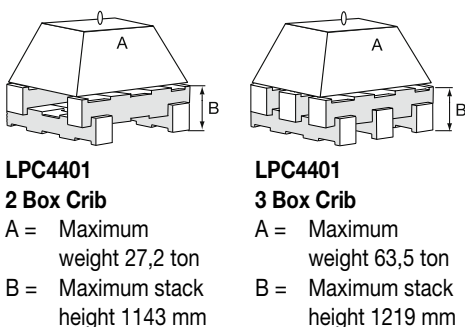

**LPC4401  
2 Box Crib**  
A = Maximum weight 27,2 ton  
B = Maximum stack height 1143 mm

**LPC4401  
3 Box Crib**  
A = Maximum weight 63,5 ton  
B = Maximum stack height 1219 mm

Cribbing Block Description	Nominal Cribbing Block Dimensions	*Single Crib Block Capacity	2 Box Crib		3 Box Crib	
			Maximum Stack Height B	Maximum Capacity A	Maximum Stack Height B	Maximum Capacity A
(inch-size)	(mm)	ton (kN)	(mm)	(ton)	(mm)	(ton)
2" x 4"	51x102x457	36,3 (355)	914	27,2	1016	63,5
4" x 4"	102x102x457	36,3 (355)	1143	27,2	1219	63,5
6" x 7"	152x178x610	54,4 (533)	1448	54,4	1625	90,7

\*\* Reference a plastic compatibility source for HDPE/PP chemical resistance.

# Resin Cribbing Blocks



## Enerpac Cribbing Blocks – for Superior Crib Stability

Enerpac resin cribbing blocks are designed to provide superior crib stability compared to standard hardwood and softwood products. Enerpac resin cribbing blocks won't fail catastrophically like wooden cribbing; instead of snapping or cracking and collapsing, it gradually deforms providing a visual warning of overload.

In addition, unlike wood products, Enerpac resin cribbing blocks do not splinter or absorb most fluids. Convenient sizes help to quickly and safely build stable cribs to support loads. Enerpac cribbing blocks have two distinct surfaces: interlocking and pyramid. The interlocking surface ensures block alignment at a 90° angle; the pyramid surface can be utilized to build crib stacks at odd angles, less than 90°.

## LPC Series



Minimum Clearance:

**53,5 mm**

Maximum Crib Height:

**1625 mm**

\*\*Maximum Capacity:

**27,2 - 90,7 ton**



### Think Safety!

Do not mix different materials in crib stacks.

Stable crib stacks require

blocks with similar friction, compression and deflection rates. Use wedges to stabilize crib stacks when necessary.

Wedges should be similar width as crib block. Distribute load over largest possible crib stack surface area.

Loads must be evenly spread over the cribbing block cribs, and pointloading must be avoided.

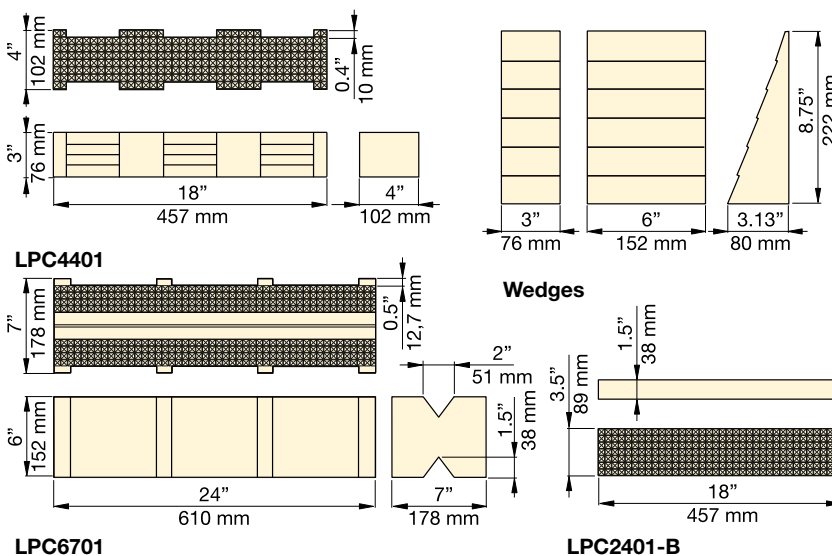

Description	Model Number	Kit piece count						Volume (m <sup>3</sup> )	Weight (kg)
		* 2" x 4" Block	* 4" x 4" Block	* 6" x 7" Block	3" Wedge	6" Wedge	Nylon Carrying Tote		
Single Blocks	LPC2401-B	1	-	-	-	-	-	2,3	1,4
	LPC4401-B	-	1	-	-	-	-	4,8	2,4
	LPC4401-Y	-	1	-	-	-	-	4,8	2,4
	LPC6701-B	-	-	1	-	-	-	15,9	11,3
	LPC6701-Y	-	-	1	-	-	-	15,9	11,3
Wedges	LPC3W-B	-	-	-	1	-	-	0,6	0,7
	LPC6W-B	-	-	-	-	1	-	2,6	1,1
2" x 4" Kits	LPC2418	18	-	-	3	-	1	46,1	28,4
	LPC2436	36	-	-	6	-	2	90,1	52,6
	LPC2472	72	-	-	9	-	4	180,7	105,9
4" x 4" Kits	LPC4409	-	5 + 4	-	2	-	1	44,7	22,6
	LPC4418	-	10 + 8	-	3	-	2	90,3	45,8
	LPC4436	-	20 + 16	-	8	-	4	182,1	92,9
	LPC4472	-	40 + 32	-	9	-	8	359,6	181,2
6" x 7" Kits	LPC6704	-	-	2 + 2	-	1	-	66,3	46,5
	LPC6708	-	-	4 + 4	-	3	-	135,1	94,1
	LPC6720	-	-	11 + 9	-	7	-	336,1	234,7
	LPC6750	-	-	28 + 22	-	8	-	833,9	1264,4

\* Distribute load over largest possible crib stack surface area. Do not load any localized area of a crib or cribbing block at more than 1100N/cm<sup>2</sup>.

▼ Shown from left to right: **JHA-356, JHA-156**



- All-directional operation on 7, 15 and 35 ton JHA-series
- Internal relief valve to prevent overloading
- Machined flat front and bottom surfaces permit flush alignment in tight corners
- Chrome plated plungers
- Pumping handle included
- Automatic by-pass port to prevent over-extension (JH-series).

## JH, JHA Series

Capacity:  
**7 - 150 ton**

Stroke:  
**76 - 155 mm**

Maximum Operating Pressure:  
**700 bar**



### Lifting Wedge and Machine Lifts

Ideal to lift the load the first few centimeters. The **LW-16** Lifting Wedge requires a very small access gap of only 10 mm.

Page: **172**



### Load Skates

For moving heavy loads easily and safely.

Page: **174**



### Cribbing Blocks

Safely support lifted loads using Enerpac Resin Cribbing. Available in three sizes and as wedges to help stabilize stacks.

Page: **54**

Style	Jack Capacity ton (kN)	Stroke (mm)	Model Number	Jack Effective Area (cm <sup>2</sup> )	Collapsed Height (mm)	Extended Height (mm)	Bottom Plate Dimensions (W x L) (mm)	Plunger Diameter (mm)	Pump Speed	 (kg)
Conventional Jacks	7 (62)	76	<b>JHA-73</b>	9,6	133	209	73 x 158	30,2	Single	5,0
	15 (133)	153	<b>JHA-156</b>	20,3	247	401	92 x 238	41,4	Single	13,2
	35 (311)	155	<b>JHA-356</b>	45,6	257	412	117 x 254	54,1	Single	18,1
	75 (667)	153	<b>JHA-756</b>	102,6	285	439	174 x 325	114,3	Single	42,6
	150 (1335)	155	<b>JHA-1506</b>	197,9	327	482	241 x 407	158,8	2-Speed	95,3
Steel Jacks	30 (267)	155	<b>JH-306</b>	38,3	254	409	95 x 242	69,9	Single	26,8
	50 (445)	154	<b>JH-506</b>	62,1	260	414	127 x 258	88,9	2-Speed	40,8
	100 (890)	153	<b>JH-1006</b>	133,1	287	440	181 x 328	130,1	2-Speed	74,4

# Steel Bottle Jacks

▼ Shown from left to right: EBJ-4GC, EBJ-50GC, EBJL-15GC, EBJ-12GC



## EBJ Series



Capacity:  
**1,4 - 90,7 ton**

Stroke:  
**77 - 508 mm**

Maximum Operating Pressure:  
**700 bar**



### Screw Feature

Heat treated, adjustable extension screw with cleated saddle on selected EBJ models helps adjusting and prevents slipping.

- Low handle effort reduces operator fatigue
- Fully serviceable
- Cast pump linkage and beam
- Pumping handle included on all models
- Safety relief valve to prevent overload
- Automatic bypass port to prevent over-extension
- Wiper seal for extended life
- Chrome plating on pump and ram plungers.

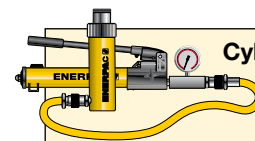

### Cylinder-Pump Sets

As an alternative to bottle jacks where the operator is required to stand remote from the jacking point, see our range of cylinder-pump sets.

Page: 62

Jack Capacity ton (kN)	Stroke (mm)	Model Number	Additional Screw Extension (mm)	Collapsed Height (mm)	Extended Height (mm)	Bottom Plate Dimensions W x L (mm)	Plunger diameter (mm)	Pump Speed	 (kg)
1,4 (13)	457	EBJL-15GC	-	552	1009	92 x 127	22,3	Single speed	5,8
1,8 (18)	95	EBJ-2GC	70	175	340	96 x 102	22,1	Single speed	3,0
2,7 (27)	508	EBJL-3GC	-	668	1176	108 x 140	28,4	Single speed	10,0
3,6 (36)	120	EBJ-4GC	70	195	385	105 x 112	28,2	Single speed	4,2
5,4 (53)	130	EBJ-6GC	80	210	420	114 x 120	34,0	Single speed	5,5
7,3 (71)	140	EBJ-8GC	80	220	440	119 x 125	38,1	Single speed	6,2
10,9 (107)	155	EBJ-12GC*	80	240	475	130 x 135	43,2	Single speed	8,0
10,9 (107)	77	EBJS-12GC	43	155	275	130 x 135	43,2	Single speed	6,6
13,6 (133)	150	EBJ-15GC	80	240	470	138 x 145	48,0	Single speed	9,4
18,1 (178)	155	EBJ-20GC*	80	250	485	145 x 155	53,0	Single speed	11,4
18,1 (178)	79	EBJS-20GC	41	165	285	145 x 155	53,0	Single speed	9,0
27,2 (267)	175	EBJ-30GC	-	285	460	150 x 190	71,1	Single speed	25,8
45,4 (445)	105	EBJ-50GC	-	240	345	190 x 255	85,1	Two speed	42,0
90,7 (890)	150	EBJ-100GC	-	310	460	240 x 300	124,2	Two speed	90,2

All EBJ-Series Jacks meet or exceed: ANSI, PALD, CE, prEN 1494: 1994 standards.

\* Short bottle jack.



▼ Shown: PRASA10027L and accessory Locking U-Rings



## Safe, Efficient, Mobile Load Lifting

- 54, 90, 136 and 181 ton capacities with pneumatic or electric pumps for the toughest jobs
- 102 mm ground clearance for transport over rail and rough terrain
- Double-acting cylinder
- Three position handle provides easy tilt back and transport
- Complies with ASME/ANSI B30.1/CE specifications
- Easy to change external filter minimizes down time
- Rugged, fully enclosed 610 mm wide frame with no exposed fittings or hoses
- SUP-R-STACK™ Extension System allows lifting at all heights without blocking.



### Pendant cord

Standard 3,6 m pendant cord for air driven units with pneumatic valves and 6,1 m pendant cord for electric driven units keeps operator away from the load.



◀ Enerpac Pow'r-Riser® used in mining operations to lift heavy equipment.

Capacity	Stroke	Model Number with Electric Pump	
ton (kN)	(mm)	(230V - 1 ph - 50Hz)	(kg)
54 (533)	356	PREME06014L	177
	686	PREME06027L	272
90 (889)	406	PREME10016L	231
	686	PREME10027L	272
	406	-	-
	686	-	-
136 (1333)	394	-	-
	673	-	-
	394	PREME15016L	258
	673	PREME15027L	321
181 (1778)	394	-	-
	673	-	-

# POW'R-RISER® Lifting Jack



## SUP-R-STACK™ Extensions

Increase useful height from 127 to 457 mm.

Model No.	Size (mm)	Model No.	Size (mm)
PRE5	127	PRE11	279
PRE7	178	PRE14	356
PRE9	229	PRE18	457
PRES6024	Extension set includes PRE5, PRE7, PRE11 and PRE18.		



## Spacers

Fine tune your extension stack height.

Model No.	Size (mm)	Model No.	Size (mm)
PRS1	25	PRS3	76
PRS2	51	-	-
PRS4	Set includes (2x) PRS1, (1x) PRS2 and (1x) PRS3.		

## PR Series



Rated Lifting Capacity:

**54 - 181 ton**

Stroke:

**356 - 686 mm**

Maximum Operating Pressure:

**700 bar**

Cap. (kN)	Swivel Load Saddle	Locking U-Rings					Set Model Number	Locking U-Ring Sets Include:								
		25 mm	76 mm	114 mm	140 mm	254 mm		Quantity & model numbers								
							2x	1x	2x	1x						
533	PRTS60	PRU11	PRU13	PRU14	-	PRU110	<sup>1)</sup> PRUS126	PRU11	PRU13	PRU14	-	<sup>2)</sup> PRUS137	PRU11	PRU13	PRU14	PRU110
889	PRTS60	PRU11	PRU13	PRU14	-	PRU110	<sup>1)</sup> PRUS126	PRU11	PRU13	PRU14	-	<sup>2)</sup> PRUS137	PRU11	PRU13	PRU14	PRU110
1333	PRTS150	PRU151	PRU153	-	PRU155	PRU1510	<sup>3)</sup> PRUS1526	PRU151	PRU153	PRU155	-	<sup>2)</sup> PRUS1537	PRU151	PRU1510	PRU155	-
1778	PRTS200	PRU201	PRU203	-	PRU205	PRU2010	<sup>3)</sup> PRUS2026	PRU201	PRU203	PRU205	-	<sup>2)</sup> PRUS2037	PRU201	PRU2010	PRU205	-

<sup>1)</sup> For 356 mm and 406 mm stroke models

<sup>2)</sup> For 686 mm stroke models

<sup>3)</sup> For 394 mm stroke models.

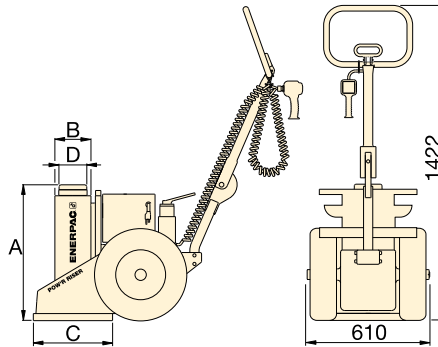

### WARNING!

**Extensions:** Any two extensions may be stacked for loads up to 54 ton. For loads over 54 ton or strokes over 356 mm only one extension and one spacer can be used.

**Spacers:** Never exceed 76 mm in total spacer height.

Model Number with Air Pump	(kg)	A (mm)	B (mm)	C (mm)	D (mm)	Max. Additional Stack Height Using Optional Extension (mm)	Valve Type
PRAMA06014L	177	610	162	356	102	813*	Manual
PRAMA06027L	272	940	162	356	102	279	
PRAMA10016L	231	660	178	457	102	533**	
PRAMA10027L	272	940	178	457	102	279	
PRASA10016L	231	660	178	457	102	533**	Pneumatic
PRASA10027L	272	940	178	457	102	279	
PRASA15016L	258	660	203	457	127	533**	Pneumatic
PRASA15027L	321	940	203	457	127	279	
-	-	660	203	457	127	533**	Manual
-	-	940	203	457	127	279	
PRASA20016L	290	660	241	457	152	533**	Pneumatic
PRASA20027L	374	940	241	457	152	279	

\* Based on one 457 mm and one 279 mm extension and one 76 mm spacer.

\*\* Based on one 457 mm extension and one 76 mm spacer.

For power source, the following characters should be inserted in the 5th space of the model number.

### Ordering Example:

**Model No. PREME06014L** is a 356 mm stroke, 54 ton model, with a manual valve and a 230 VAC, 1-ph., 50 Hz electric motor.

- A Air Pump, 1416 l/min air consumption at 5,5 bar
- B 115 VAC, 1-ph., 50-60 Hz, 20 A
- E 208-240 VAC, 1-ph., 50-60 Hz, Euro Plug, 10 A
- I 208-240 VAC, 1-ph., 50-60 Hz, USA Plug, 10 A
- G <sup>1)</sup> 208-240 VAC, 3-ph., 50-60 Hz
- W <sup>1)</sup> 380-415 VAC, 3-ph., 50-60 Hz
- J <sup>1)</sup> 440-480 VAC, 3-ph., 50-60 Hz
- R <sup>1)</sup> 575 VAC, 3-ph., 50-60 Hz.

<sup>1)</sup> Not available for 54 ton capacity.

▼ From left to right: P-142ALSS, P-392ALSS, V-152NV, V-66NV, RC-256NV, RC-106NV, RC-53NV



## Maximum Corrosion Resistance



### Applications

For use in wet environments such as food processing, pulp and paper, mining, construction and applications in high temperature or in welding areas.

- Corrosion resistant, nickel-plated valves and cylinders
- Stainless steel pump inserts will not corrode
- Viton® Seals provide heat and chemical resistance
- Anodized aluminum pump reservoirs and plastic encapsulated pump bodies resist wet environments
- Two-speed operation reduces pump handle strokes 78% compared to single-speed pumps
- Pump handles lock for easy carrying.



### Hoses

Enerpac offers a complete line of high quality hydraulic hoses. To ensure the integrity of your system, specify only Enerpac hydraulic hoses.

Page: **120**

CYLINDER CHART		Cylinder Capacity	Stroke	Model Number	Oil Capacity	Pressure Rating	Collapsed Height	Extended Height	Outside Diameter
		ton (kN)	(mm)		(cm <sup>3</sup> )	(bar)	A (mm)	B (mm)	D (mm)
		5 (45)	76	RC-53NV	50	700	165	241	38
		10 (101)	51	RC-102NV	78	700	121	175	57
		10 (101)	156	RC-106NV	225	700	247	403	57
		25 (232)	156	RC-256NV	528	700	273	431	85

  

HAND PUMP CHART		Pump Type	Oil Capacity	Model Number	Pressure Rating	Oil Displacement per Stroke	Port Dimension	Piston Stroke
			(cm <sup>3</sup> )		(bar)	(mm <sup>3</sup> )		(mm)
		Two Speed	327	P-142ALSS	14 / 700	3,62 / 0,90	1/4"-18NPTF	12,7
			901	P-392ALSS	14 / 700	11,26 / 2,47	3/8"-18NPTF	25,4

VALVE CHART*		Valve Type	Model Number	Pressure Function	Pressure Rating (bar)
		Manual Check Valve	V-66NV *	Load holding with cylinders	700
		Pressure Relief Valve	V-152NV *	Limits system pressure, ± 3% repeatability	55 -700

\* See page 134 for valve function information of standard model products.

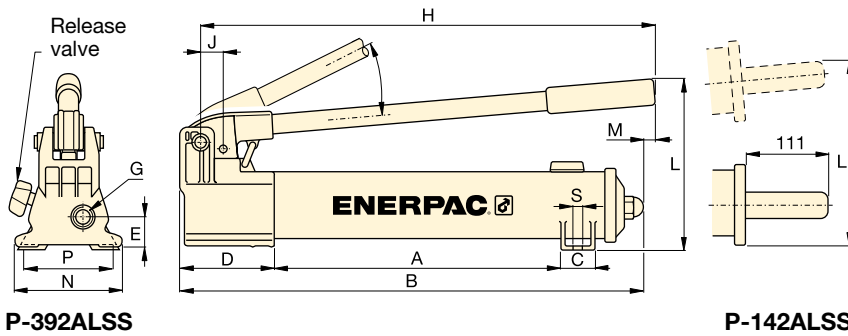

**P-392ALSS**

**P-142ALSS**

## RC P V Series



Cylinder Capacity:  
**5 - 25 ton**

Stroke:  
**54 - 158 mm**

Maximum Operating Pressure:  
**700 bar**

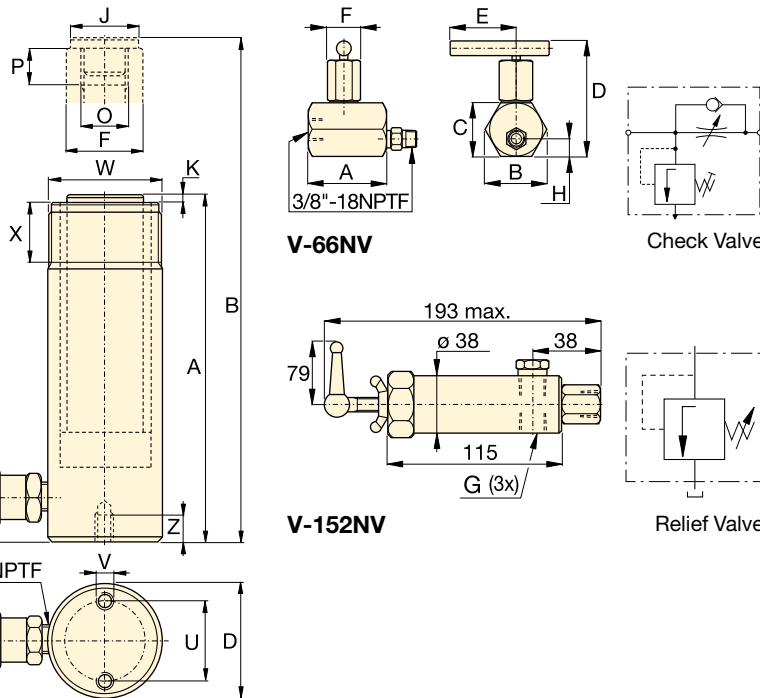

**V-66NV**

Check Valve

**V-152NV**

Relief Valve

**RC-102NV, RC-106NV, RC-256NV**



**Multifluid Hand Pumps**  
MP-Series corrosion resistant hand pumps for low pressure filling and high pressure testing applications, suitable for a wide range of fluids.

Page: **72**

Plunger Diam.	Base to Advance Port	Saddle Diam.	Saddle Protrusion from Plngr.	Plunger Internal Thread	Plunger Thread Length	Base Mounting Holes			Collar Thread	Collar Thread Length	Weight (kg)	Model Number
						Bolt Circle U (mm)	Thread V	Thrd. Depth Z (mm)				
25,4	19	25	6	¾"-16	14	25	¼"-20UN	14	1½"-16	28	1,5	RC-53NV
38,1	19	35	6	1"-8	19	39	5/16"-18UN	12	2¼"-14	28	2,3	RC-102NV
38,1	19	35	6	1"-8	19	39	5/16"-18UN	12	2¼"-14	28	4,4	RC-106NV
57,2	25	50	10	1½"-16	25	58	½"-13UN	19	35/16"-12	49	10,0	RC-256NV

Pump Dimensions (mm)													Weight (kg)	Model Number
A	B	C	D	E	G	H	J	L	M	N	P	S		
185	336	28	85	28	¼"-18 NPTF	319	19	143	-	95	80	7	2,0	P-142ALSS
344	533	36	99	33	⅜"-18 NPTF	522	30	177	16	120	-	-	4,1	P-392ALSS

Valve Dimensions (mm)									Weight (kg)	Model Number
A	B	C	D	E	F	G	H			
88,9	57,1	50,8	101,6	50,8	20,8	⅜"-18 NPTF	25,4	1,8	V-66NV	
115,1	-	38,1	-	79,2	193,5	⅜"-18 NPTF	38,9	1,6	V-152NV	



▼ Shown cylinder-pump set: SCR-1010H



## The Quickest and Easiest Way to Start Working Right Away





- Optimum match of individual components
- All sets are ready-for-use
- Sets include 1,8 m safety hose and gauge with gauge adaptor
- All hand pumps are two-speed.



### Speed Chart

See the Enerpac Cylinder Speed Chart in our 'Yellow Pages' section.

Page: **249**

1 Cylinder Selection (See Cylinder Section of this catalog for full product descriptions)		Set Capacity ton (kN)	Cylinder Model Number	Stroke (mm)	Collapsed Height (mm)
 <p><b>Single-Acting, General Purpose Cylinders:</b> For maximum versatility. <b>RC-Series</b></p>	<p>Page: <b>6</b></p>	5 (45)	RC-55	127	215
		10 (101)	RC-102	54	121
			RC-106	156	247
			RC-1010	257	349
		15 (142)	RC-154	101	200
			RC-156	152	271
		25 (232)	RC-252	50	165
			RC-254	102	215
			RC-256	158	273
			RC-2514	362	476
50 (498)	RC-506	159	282		
 <p><b>Single-Acting, Low Height Cylinders:</b> Ideal where space is restricted. <b>RCS-Series</b></p>	<p>Page: <b>22</b></p>	10 (101)	RCS-101	38	88
		20 (201)	RCS-201	45	98
		30 (295)	RCS-302	62	117
		45 (435)	RCS-502	60	122
		90 (887)	RCS-1002	57	141
 <p><b>Single-Acting, Hollow Cylinders:</b> For pushing and pulling applications. <b>RCH-Series</b></p>	<p>Page: <b>26</b></p>	13 (125)	RCH-121	42	120
		20 (215)	RCH-202	49	162
		30 (326)	RCH-302	64	178
		60 (576)	RCH-603	76	247
		95 (933)	RCH-1003	76	254
 <p><b>Pull Cylinders:</b> The ultimate in pulling power. <b>BRP-Series</b></p>	<p>Page: <b>24</b></p>	10 (105)	BRP-106C	151	587
			BRP-106L	151	541
		30 (326)	-	-	-
			BRP-306	155	1085
50 (505)	BRP-606	152	719		

# Single-Acting Cylinder-Pump Sets

## SELECTION EXAMPLE

### Selected cylinder:

- RC-106, Single-Acting cylinder with 156 mm stroke

### Selected pump:

- P-392, Lightweight hand pump

### Set model number:

- SCR-106H

### Included:

- HC-7206 hose
- GF-10B gauge
- GA-2 adaptor

## SET SELECTION:

- 1 Select the cylinder
- 2 Select the pump
- 3 Find the set model number in the blue matrix

## SC Series



Capacity:

**5 - 95 ton**

Stroke:

**38 - 362 mm**

Maximum Operating Pressure:

**700 bar**

## 2 Pump selection (See the Pump Section in this catalog for full product descriptions.)

## Accessories included

Hand Pump P-142	Hand Pump P-392	Hand Pump P-80	Foot Pump P-392FP	XA-Series Air Pump XA-11	Hose Model Number	Gauge Model Number	Gauge Adaptor Model Nr.
<b>SCR-55H</b>	-	-	-	-	HC-7206	GP-10S	GA-4
-	<b>SCR-102H</b>	-	<b>SCR-102FP</b>	<b>SCR-102XA</b>	HC-7206	GF-10B	GA-2
-	<b>SCR-106H</b>	-	<b>SCR-106FP</b>	<b>SCR-106XA</b>	HC-7206	GF-10B	GA-2
-	<b>SCR-1010H</b>	-	<b>SCR-1010FP</b>	<b>SCR-1010XA</b>	HC-7206	GF-10B	GA-2
-	<b>SCR-154H</b>	-	<b>SCR-154FP</b>	<b>SCR-154XA</b>	HC-7206	GP-10S	GA-2
-	<b>SCR-156H</b>	-	<b>SCR-156FP</b>	<b>SCR-156XA</b>	HC-7206	GP-10S	GA-2
-	<b>SCR-252H</b>	-	<b>SCR-252FP</b>	<b>SCR-252XA</b>	HC-7206	GF-20B	GA-2
-	<b>SCR-254H</b>	-	<b>SCR-254FP</b>	<b>SCR-254XA</b>	HC-7206	GF-20B	GA-2
-	<b>SCR-256H</b>	-	<b>SCR-256FP</b>	<b>SCR-256XA</b>	HC-7206	GF-20B	GA-2
-	-	<b>SCR-2514H</b>	-	<b>SCR-2514XA<sup>1)</sup></b>	HC-7206	GF-20B	GA-2
-	-	<b>SCR-506H</b>	-	<b>SCR-506XA<sup>1)</sup></b>	HC-7206	GF-50B	GA-2
-	<b>SCL-101H</b>	-	<b>SCL-101FP</b>	<b>SCL-101XA</b>	HC-7206	GF-10B	GA-2
-	<b>SCL-201H</b>	-	<b>SCL-201FP</b>	<b>SCL-201XA</b>	HC-7206	GF-230B	GA-2
-	<b>SCL-302H</b>	-	<b>SCL-302FP</b>	<b>SCL-302XA</b>	HC-7206	GF-230B	GA-2
-	<b>SCL-502H</b>	-	<b>SCL-502FP</b>	<b>SCL-502XA</b>	HC-7206	GF-510B	GA-2
-	-	<b>SCL-1002H</b>	-	-	HC-7206	GF-510B	GA-2
<b>SCH-121H</b>	-	-	-	-	HB-7206	GF-120B	GA-4
-	<b>SCH-202H</b>	-	<b>SCH-202FP</b>	<b>SCH-202XA</b>	HC-7206	GF-813B	GA-3
-	<b>SCH-302H</b>	-	<b>SCH-302FP</b>	<b>SCH-302XA</b>	HC-7206	GF-813B	GA-3
-	-	<b>SCH-603H</b>	-	<b>SCH-603XA<sup>1)</sup></b>	HC-7206	GF-813B	GA-3
-	-	<b>SCH-1003H</b>	-	-	HC-7206	GP-10S	GA-2
-	<b>SCP-106CH</b>	-	<b>SCP-106CFP</b>	-	HC-7206	GP-10S	GA-2
-	<b>SCP-106LH</b>	-	<b>SCP-106LFP</b>	-	HC-7206	GP-10S	GA-2
-	-	-	-	-	-	-	-
-	-	<b>SCP-306H</b>	-	-	HC-7206	GP-10S	GA-2
-	-	<b>SCP-606H</b>	-	-	HC-7206	GP-10S	GA-2

<sup>1)</sup> With XA-12 air pump.

ENERPAC hydraulic pumps are available in over 1000 different configurations. Whatever your high-pressure pump needs are... speed, control, intermittent or heavy duty cycle you will find an Enerpac pump suited to the application.

Featuring Hand, Battery, Electric, Air and Gasoline powered models, with multiple reservoir and valve configurations, Enerpac offers the most comprehensive pump line available.



### Pump Selection

For help in selecting the correct pump for your application, please review our 'Yellow Pages'.

If you require further assistance, contact the Enerpac office located near you.

Page: 242

























### Torque Wrench Pumps

System matched air and electric pumps provide control to operate Enerpac Torque Wrenches.

Page: 202



# Pumps and Directional Control Valves Section Overview

Power Source	Pump Types	Maximum Reservoir Capacity (litres)	Max. Flow at Rated Pressure (l/min)	Max. Power Consumption	Series	Image	Page
<b>Manual</b>	<b>Lightweight Hand Pumps</b> Exclusively from Enerpac	<b>2,5</b>	<b>2,50</b> (cm <sup>3</sup> /stroke)	–	<b>P</b>		<b>66</b> ▶
	<b>Steel Hand Pumps</b>	<b>7,4</b>	<b>4,75</b>	–	<b>P</b>		<b>68</b> ▶
	<b>Low Pressure Hand Pumps</b>	<b>3,3</b>	<b>9,50</b>	–	<b>P</b>		<b>70</b> ▶
	<b>Multifluid Hand Pumps</b> Pumping Fluids up to 1000 bar	–	<b>21,8</b> (cm <sup>3</sup> /stroke)	–	<b>MP</b>		<b>72</b> ▶
	<b>Foot Pump</b> For Hands Free Operation	<b>0,5</b>	<b>2,47</b> (cm <sup>3</sup> /stroke)	–	<b>P</b>		<b>73</b> ▶
	<b>Ultra-High Pressure Hand Pumps</b> Pressure up to 2800 bar	<b>1,0</b>	<b>2,49</b> (cm <sup>3</sup> /stroke)	–	<b>P 11</b>		<b>74</b> ▶
<b>Electric</b>	<b>Battery Powered Hydraulic Pumps</b> Cordless Hydraulic Power	<b>3,8</b>	<b>0,25</b>	<b>0,37</b> (kW)	<b>BP</b>		<b>76</b> ▶
	<b>Economy Series</b> Compact and Portable	<b>3,8</b>	<b>0,32</b>	<b>0,37</b> (kW)	<b>PU</b>		<b>78</b> ▶
	<b>Submerged Series</b> Powerful and Low-Noise	<b>5,5</b>	<b>0,27</b>	<b>0,37</b> (kW)	<b>PE</b>		<b>80</b> ▶
	<b>Z-Class Pumps, Portable ZU-Series</b>	<b>40</b>	<b>1,0</b>	<b>1,25</b> (kW)	<b>ZU</b>		<b>86</b> ▶
	<b>Z-Class Pumps, Heavy-Duty ZE-Series</b>	<b>40</b>	<b>2,73</b>	<b>5,60</b> (kW)	<b>ZE</b>		<b>92</b>
	<b>8000 and 9000-Series</b> High Flow and Split Flow Pumps	<b>80</b>	<b>8,0</b>	<b>9,50</b> (kW)	<b>PP</b>		<b>98</b> ▶
<b>Air</b>	<b>XA-Series Pumps, with XVARI® Technology</b> For Productivity and Ergonomics	<b>2,0</b>	<b>0,25</b>	<b>991</b> (l/min)	<b>XA</b>		<b>100</b> ▶
	<b>Turbo II Air Hydraulic Pumps</b> Compact Air Over Hydraulic	<b>5,0</b>	<b>0,16</b>	<b>340</b> (l/min)	<b>PAT</b>		<b>102</b> ▶
	<b>Air Hydraulic Pumps</b> Single and Twin-Air Motor	<b>1,3</b>	<b>0,13</b>	<b>255</b> (l/min)	<b>PA</b>		<b>104</b> ▶
		<b>8,0</b>	<b>0,15</b>	<b>510</b> (l/min)	<b>PAM</b>		<b>105</b>
	<b>Z-Class Air Hydraulic Pumps</b> Modular Air Pumps	<b>40,0</b>	<b>1,31</b>	<b>2840</b> (l/min)	<b>ZA</b>		<b>106</b> ▶
	<b>ATP-Series Air Pump</b> High Pressure Air Pump up to 1500 bar	<b>3,8</b>	<b>0,07</b>	<b>590</b> (l/min)	<b>ATP</b>		<b>108</b> ▶
<b>Gasoline</b>	<b>Atlas PGM-Series</b> Small and Lightweight	<b>8,0</b>	<b>0,66</b>	<b>2,2</b> (kW)	<b>PGM</b>		<b>109</b> ▶
	<b>Z-Class Gasoline Hydraulic Pumps</b> Gas Powered High Flow Pumps	<b>40,0</b>	<b>1,64</b>	<b>4,8</b> (kW)	<b>ZG5</b>		<b>110</b> ▶
		<b>40,0</b>	<b>3,30</b>	<b>9,7</b> (kW)	<b>ZG6</b>		<b>112</b> ▶
<b>Directional Control Valves</b>					<b>VM, VC VE</b>		<b>113</b> ▶



# P-Series, Lightweight Hand Pumps

▼ Shown from top to bottom: P-802, P-842, P-202, P-142



- Lightweight and compact design
- Durable glass-filled nylon reservoir and nylon encapsulated aluminium pump base for maximum corrosion resistance
- Two-speed operation reduces handle strokes by as much as 78% over single speed pumps
- Lower handle effort to minimize operator fatigue
- Integral 4-way valve on P-842 for operation of double-acting cylinders
- Handle lock and lightweight construction for easy carrying
- Large oil capacities to power a wide range of cylinders or tools
- Non-conductive fiberglass handle for operator safety
- Internal pressure relief valve for overload protection.

▼ Cylinder-pump set SCR-254H used to support the construction while monitoring pressure and load with the gauge.



## Exclusively from Enerpac



### Cylinder Matching Chart

For help in selecting the correct hand pump for your application, please refer to the Cylinder Matching Chart located in the 'Yellow Pages'.

Page: 242



### Speed Chart

To determine how a specific pump will operate your cylinder, see the Pump-Cylinder Speed Chart in the 'Yellow Pages'.

Page: 249



### Tank Kits:

When a return-to-tank port is required, the Tank Kits provide a 7/16" -20 UN port at the rear of the reservoir.

PC-20	Fits P-141, P-142
PC-25	Fits P-202, P-391, P-392



### High Temperature and Corrosion Resistant Hand Pumps

The P-142 and P-392 hand pumps are available with Viton® seals, stainless steel pistons and anodized aluminium reservoir for use in extreme environments.

Page: 60

Pump Type	Usable Oil Capacity (cm <sup>3</sup> )	Model Number	Pressure Rating** (bar)		Oil Displacement per Stroke (cm <sup>3</sup> )		Max. Handle Effort (kg)
			1 <sup>st</sup> stage	2 <sup>nd</sup> stage	1 <sup>st</sup> stage	2 <sup>nd</sup> stage	
			Single-Speed	327	P-141	-	
	901	P-391	-	700	-	2,47	38,6
Two-Speed	327	P-142*	13	700	3,62	0,90	35,4
	901	P-202	13	700	3,62	0,90	28,6
	901	P-392*	13	700	11,26	2,47	42,2
	2540	P-802	27	700	39,33	2,47	43,1
	2540	P-842	27	700	39,33	2,47	43,1

\* Available as set, see note on next page.

\*\* Contact Enerpac for applications where operating pressure is less than 10% of pressure rating.

# Lightweight Hand Pumps

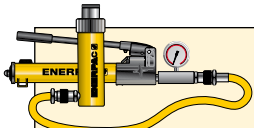

## Pump-Cylinder Sets

All pumps marked with an \* are available as **sets** (pump, cylinder, gauge, couplers and hose) for your ordering convenience.

Page: **62**

## P Series



Reservoir Capacity:

**327 - 2540 cm<sup>3</sup>**

Flow at Rated Pressure:

**0,90 - 2,47 cm<sup>3</sup>/stroke**

Operating Pressure:

**700 bar**

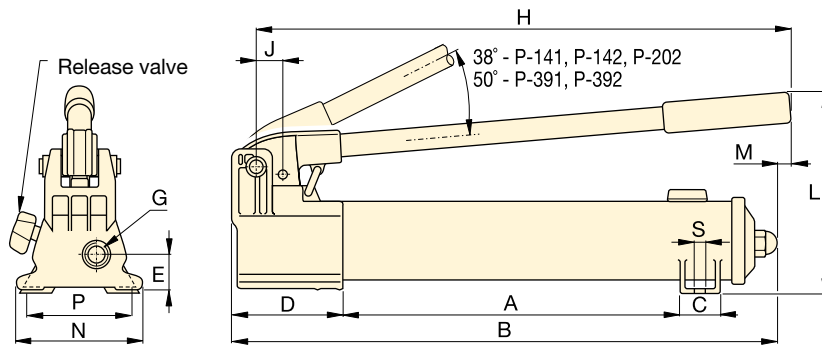

**P-141, P-142, P-202, P-391, P-392**

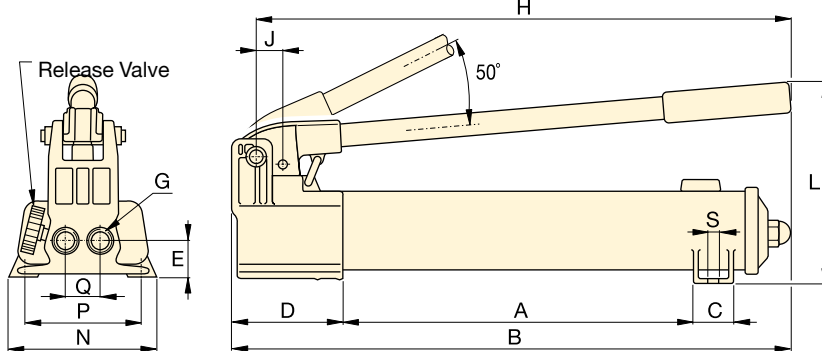

**P-802**

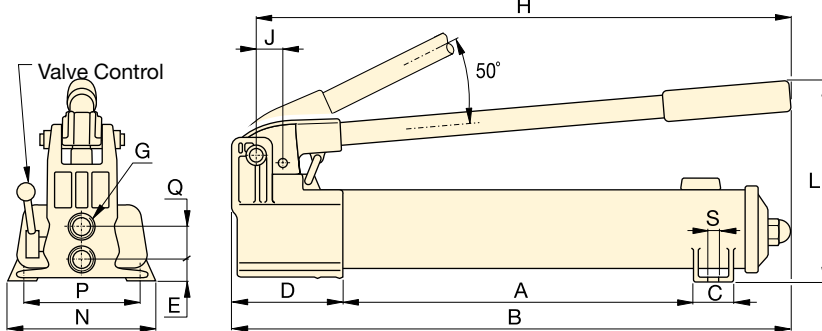

**P-842**



## Hoses

Enerpac offers a complete line of high quality hydraulic hoses. To ensure the integrity of your system, specify only genuine Enerpac hydraulic hoses.

Page: **120**



## Gauges

Minimize the risk of overloading and ensure long, dependable service from your equipment. Refer to the

System Components section for a full range of gauges.

Page: **128**



## Foot Pump P-392FP

For handsfree operation the lightweight and robust **P-392FP** Foot Pump is the perfect choice.

Page: **73**

Piston Stroke	Dimensions (mm)															Model Number
	(mm)	A	B	C	D	E	G	H	J	L	M	N	P	Q	S	
12,7	185	336	28	85	28	1/4"-18 NPTF	319	19	143	-	95	80	-	7	2,4	<b>P-141</b>
25,4	344	533	36	99	33	3/8"-18 NPTF	522	30	177	16	120	-	-	-	4,1	<b>P-391</b>
12,7	185	336	28	85	28	1/4"-18 NPTF	319	19	143	-	95	80	-	7	2,4	<b>P-142*</b>
12,7	344	509	36	85	28	1/4"-18 NPTF	400	19	144	16	95	-	-	-	3,4	<b>P-202</b>
25,4	344	533	36	99	33	3/8"-18 NPTF	522	30	177	16	120	-	-	-	4,1	<b>P-392*</b>
25,4	337	552	45	133	35	3/8"-18 NPTF	527	30	228	-	181	120	35	10	8,2	<b>P-802</b>
25,4	337	552	45	133	20	3/8"-18 NPTF	527	30	228	-	181	120	36	10	10,0	<b>P-842</b>

# P-Series, Steel Hand Pumps

▼ Shown from top to bottom: P-462, P-84, P-801, P-77, P-80, P-39



- Two-speed operation for reduced operator fatigue (except P-39)
- 4-way valving on the P-84 and P-464 for operation of double-acting cylinders
- External load release valve on remaining models for single-acting cylinder operation
- Internal pressure relief valve for overload protection
- Large oil capacity to power a wide range of cylinders or tools.

▼ In the absence of a power supply, the P-80 Hand Pump offers a powerful solution.



## The Solution for Tough Jobs



### Two Speed Pumps

Recommended for applications where cylinder plunger must advance rapidly to load contact, and applications where greater oil capacities are required, such as multiple cylinder hook-ups.



### Foot Pump Conversion Kits

Convert your P-39 to foot power with the **PC-10** Kit. Includes instructions for easy conversion.



### Gauges

Minimize the risk of overloading and ensure long, dependable service from your equipment. Refer to the System Components section for a full range of gauges.

Page: 128



### 4-Way Control Valve

P-84 and P-464 feature a manual 4-way control valve, designed for use with one double-acting or two single-acting cylinders. For system set-up information:

Page: 244

Pump Type	Usable Oil Capacity (cm <sup>3</sup> )	Model Number	Pressure Rating** (bar)		Oil Displacement per Stroke (cm <sup>3</sup> )		Max. Handle Effort (kg)
			1 <sup>st</sup> stage	2 <sup>nd</sup> stage	1 <sup>st</sup> stage	2 <sup>nd</sup> stage	
<b>Single</b>	655	<b>P-39</b>	-	700	-	2,62	50
<b>Two-Speed</b>	770	<b>P-77</b>	14	700	16,00	2,41	43
	2200	<b>P-80*</b>	25	700	16,22	2,46	47
	4080	<b>P-801</b>	25	700	16,22	2,46	47
	2200	<b>P-84</b>	25	700	16,22	2,46	47
	7423	<b>P-462</b>	14	700	126,20	4,75	49
	7423	<b>P-464</b>	14	700	126,20	4,75	49

\* Available as a set, see note on next page.

\*\* Contact Enerpac for applications where operating pressure is less than 10% of pressure rating.

# Steel Hand Pumps

## P Series



Reservoir Capacity:  
**655 - 7423 cm<sup>3</sup>**

Flow at Rated Pressure:  
**2,46 - 4,75 cm<sup>3</sup>/stroke**

Maximum Operating Pressure:  
**700 bar**

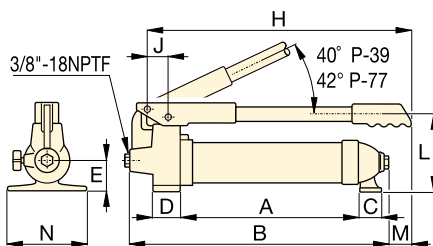

**P-39, P-77**

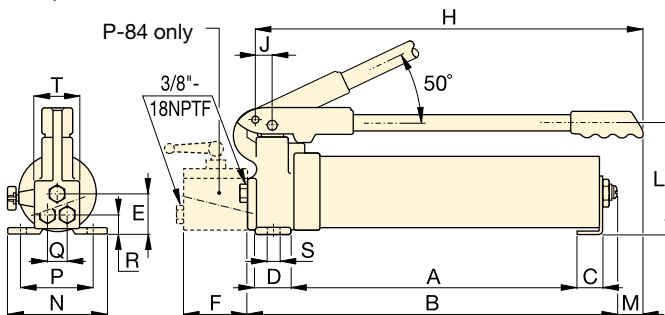

**P-80, P-801, P-84**

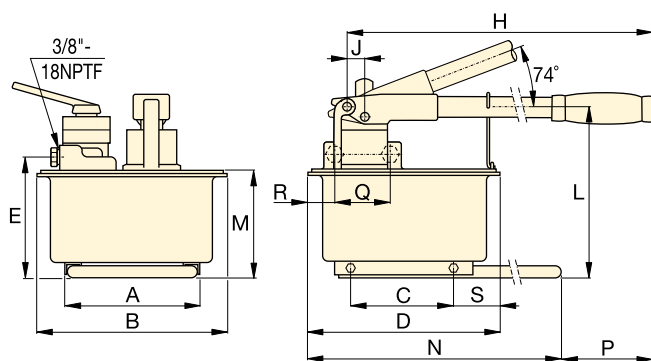

**P-462, P-464**

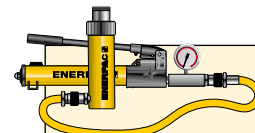

### Pump-Cylinder Sets

The P-80 is also available as set (pump, cylinder, gauge, couplers and hose) for your ordering convenience.

Page: **62**



### Speed Chart

To determine how a specific pump will operate your cylinder, see the Pump-Cylinder Speed Chart in the 'Yellow Pages'.

Page: **249**



### Cylinder Matching Chart

For help in selecting the correct hand pump for your application, please refer to the Cylinder Matching Chart located in the 'Yellow Pages'.

Page: **242**

Piston Stroke (mm)	Dimensions (mm)																Model Number	
	A	B	C	D	E	F	H	J	L	M	N	P	Q	R	S	T		
20,6	393	520	33	38	32	-	464	30	119	65	133	-	-	-	-	-	5,9	<b>P-39</b>
25,4	418	525	33	40	52	-	560	34	115	50	120	-	-	-	-	-	6,8	<b>P-77</b>
25,4	425	539	25	44	54	-	527	29	174	19	146	121	-	21	8	67	10,9	<b>P-80*</b>
25,4	659	782	25	44	54	-	772	29	174	-	146	121	-	21	8	67	14,1	<b>P-801</b>
25,4	425	539	25	44	-	64	527	29	174	19	146	121	38	43	8	67	13,2	<b>P-84</b>
38,1	210	308	163	320	195	-	671	25	270	175	650	92	-	-	80	-	27,7	<b>P-462</b>
38,1	210	308	163	320	195	-	671	25	270	175	650	92	89	68	80	-	27,7	<b>P-464</b>



# P-Series, Low Pressure Hand Pumps

▼ Shown from left to right: P-25, P-51, P-18



- P-25 and P-50 pump oil in both forward and reverse handle movement improving overall efficiency, ideal when mounting space is restricted
- External load-release valve
- Internal pressure-relief valve for overload protection
- P-51 can be operated in horizontal and vertical position with pump head and oil outlet facing downwards.

## When Less Than 700 Bar is All You Need



### Gauges

Minimize the risk of overloading and ensure long, dependable service from your equipment. Refer to the System Components section for a full range of gauges.

Page: 128



### Hoses

Enerpac offers a complete line of high quality hydraulic hoses. To ensure the integrity of your system, specify only genuine Enerpac hydraulic hoses.

Page: 120

▼ P-18 hand pump used for locking the rotating table for marble polishing.



Pump Type	Usable Oil Capacity (cm <sup>3</sup> )	Model Number	Pressure Rating (bar)	Oil Displacement per Stroke (cm <sup>3</sup> )	Max. Handle Effort (kg)
Single-Speed	295	P-18	200	2,62	26
	3277	P-25	175	9,50	27
	3277	P-50	350	4,75	27
	819	P-51	200	4,10	27

# Low Pressure Hand Pumps

## P Series



Reservoir Capacity:  
**295 - 3277 cm<sup>3</sup>**

Flow at Rated Pressure:  
**2,62 - 9,50 cm<sup>3</sup>/stroke**

Maximum Operating Pressure:  
**175 - 350 bar**

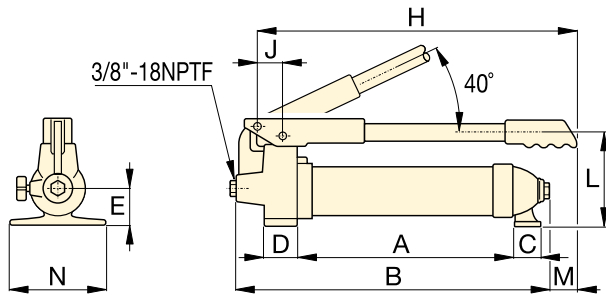

**P-18**

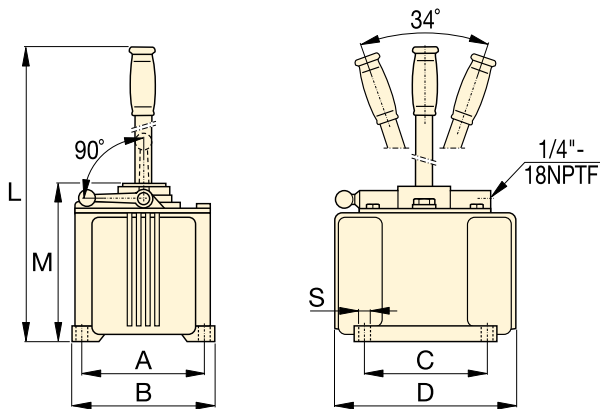

**P-25, P-50**

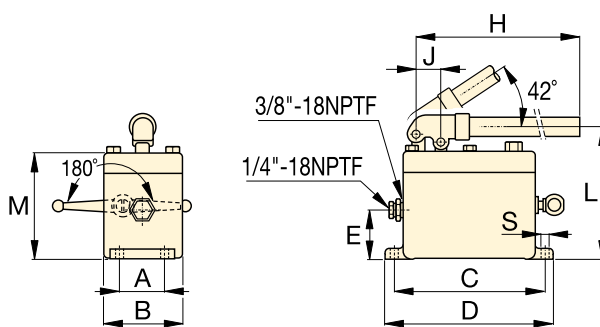

**P-51**



### MP-Series Multifluid Hand Pumps

Corrosion resistant hand pumps for low pressure filling and high pressure testing applications, suitable for a wide range of fluids.

Page: **72**

▼ P-51 hand pumps used with RC-series cylinders to keep wooden layers under pressure during lamination of plates.



Piston Stroke	Dimensions (mm)												Model Number
	(mm)	A	B	C	D	E	H	J	L	M	N	S	
20,6	210	327	33	38	48	216	30	111	13	133	-	5,0	<b>P-18</b>
38,1	152	173	152	240	-	-	-	684	200	-	10	16,3	<b>P-25</b>
38,1	152	173	152	240	-	-	-	684	200	-	10	16,8	<b>P-50</b>
25,4	52	92	181	200	57	610	29	160	129	-	9	5,4	<b>P-51</b>

# MP-Series, Multifluid Hand Pumps

▼ Shown: **MP-110**



- Unbeatable corrosion resistance
- Standard supplied with Nitrile seals – can be used for a wide range of fluids such as demineralised water, oil/water emulsions, waterglycols, mineral oils
- Two speed pumps up to 1000 bar pressure
- Buna Nitrile seals can be exchanged with optional EPDM seal for use with Skydrol or brake fluids
- Impregnated aluminium anodized pump housing with stainless steel internal pumping components
- Externally adjustable pressure relief valve
- 1/4" NPTF gauge port.

▼ MP-Series pumps are ideal for testing and filling applications.



## MP Series

Flow at Rated Pressure:

**2,2 - 21,8 cm<sup>3</sup>/stroke**

Maximum Operating Pressure:

**110 - 1000 bar**



### Multifluid Pump Applications

- Filling and testing of aircraft systems as shock absorbers
- Testing of aircraft systems using Skydrol fluid
- Testing of pressure vessels
- Operation of single-acting hydraulic tools and cylinders.



### Optional Reservoir Kit

Includes 10 litres tank with skid frame, top plate with reservoir seal, suction pipe and mounting bolts. Useable oil capacity is 7,4 litres. For use for mineral oil applications only.  
Order model number: **MP-10T**.

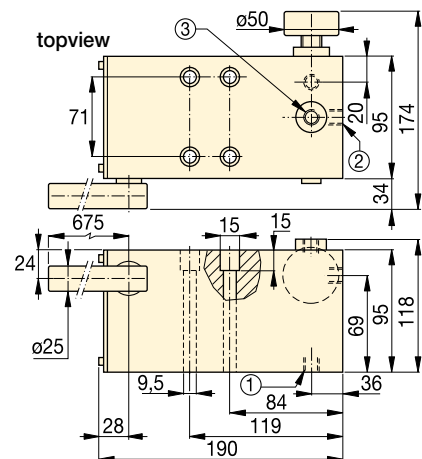

**MP-110, 350, 700, 1000**

- ① Suction / Tank return port 3/8"-18 NPTF
- ② Pressure port 3/8"-18 NPTF
- ③ Gauge port 1/4"-18 NPTF

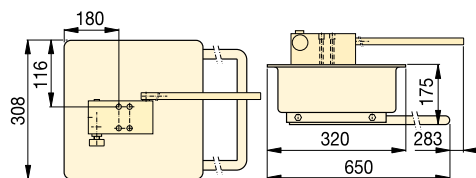

**MP-10T**

Pump Type	Usable Oil Capacity <sup>1)</sup> (cm <sup>3</sup> )	Model Number	Pressure Rating (bar)		Oil Displacement per Stroke (cm <sup>3</sup> )		Max. Handle Effort (kg)	Piston Stroke (mm)	Piston Weight (kg)
			1st stage	2nd stage	1st stage	2nd stage			
Two Speed	*	<b>MP-110</b>	35	110	52,6	21,8	45	26,5	6,6
	*	<b>MP-350</b>	35	350	52,6	7,8	45	26,5	6,6
	*	<b>MP-700</b>	35	700	52,6	3,1	45	26,5	6,6
	*	<b>MP-1000</b>	35	1000	52,6	2,2	45	26,5	6,6

Note: MP-Pump includes 1,5 mm thick gasket for reservoir mounting.

<sup>1)</sup> MP-Series pumps requires the use of an external reservoir.

# Lightweight Hydraulic Foot Pump

▼ Shown: P-392FP



- Robust, durable and compact
  - Steel frame for maximum stability
  - Steel pumping handle
  - Aluminium reservoir
- Foot pedal lock and lightweight construction for easy carrying
- Two-speed operation reduces foot pedal strokes
- Large foot-pad release valve for controlling load descent
- Internal pressure relief valve for overload protection.

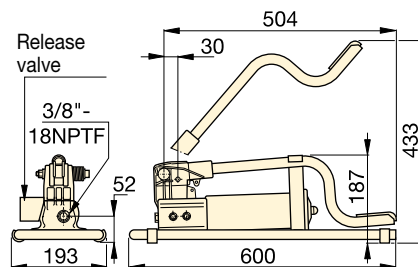

Usable Oil Capacity (cm <sup>3</sup> )	Model Number	Pressure Rating (bar)		Oil Displacement per Stroke (cm <sup>3</sup> )		Max. Handle Effort (kg)	Piston Stroke (mm)	Piston Weight (kg)
		1st stage	2nd stage	1st stage	2nd stage			
492	P-392FP *	15	700	11,26	2,47	42	25,4	7,0

\* Available as set, see note on this page.

## P Series



Reservoir Capacity:

**492 cm<sup>3</sup>**

Flow at Rated Pressure:

**2,47 cm<sup>3</sup>/stroke**

Maximum Operating Pressure:

**700 bar**

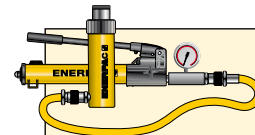

### Pump-Cylinder Sets

The P-392FP is available as **set** (pump, cylinder, gauge, couplers and hose) for your ordering convenience.

Page: 62



### Hoses

Enerpac offers a complete line of high quality hydraulic hoses. To ensure the integrity of your system, specify only genuine Enerpac hydraulic hoses.

Page: 120

▼ P-392FP offers the advantage of hands free operation to handle and control the tool or cylinder.





# P, 11-Series, Ultra-High Pressure Hand Pumps

▼ Shown from left to right: 11-100, P-2282



## Ultra-High Pressure up to 2800 bar



### 2-Way Shut-Off Valve Model Nr. 72-750

For 2800 bar applications requiring a shut-off valve or gauge snubber.

Made of 318 Stainless Steel and utilizing .38 inch cone fittings, it is the perfect selection for use with your ultra-high pressure hand pump.



### Test System Gauges

Ideal for monitoring pressure in your hydraulic circuit.

Test System Gauges, such as the T6010L, are available with cone threads or NPTF threads and a variety of pressure ranges.

Page: 130

- Two-speed operation on the P-2282 allows for faster fill operation, reducing cycle times for many testing applications
- 303 Stainless steel construction on the 11-100 and 11-400 models enable use with many different fluids, such as distilled water, diesters, silicones, soluble oils and petroleum
- Large release knob for improved control of pressure release
- Outlet ports are 3/4"-16 cone for 2800 bar rating
- Ultra-high pressure fittings feature all stainless steel construction except adaptor 41-366 which features nickel plated carbon steel construction.

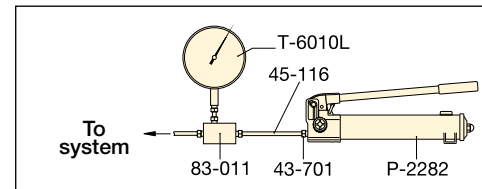

▲ Typical Test System

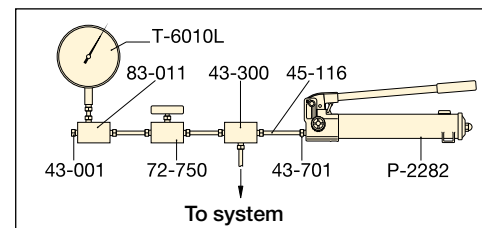

▲ Test System with Gauge and Snubber

### Cone Seal

Stainless Steel High Pressure fittings seal on a 'cone' surface and do not require pipe sealer. The Gland Nut holds the sleeve and tubing tight against the cone surface to provide a 2800 bar seal.

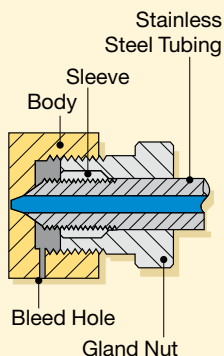









Pump Type	Usable Oil Capacity (cm <sup>3</sup> )	Model Number	Pressure Rating* (bar)		Oil Displacement per Stroke (cm <sup>3</sup> )		Max. Handle Effort (kg)
			1 <sup>st</sup> stage	2 <sup>nd</sup> stage	1 <sup>st</sup> stage	2 <sup>nd</sup> stage	
Two-Speed	983	P-2282	13	2800	16,22	0,61	48,1
Single-Speed	737	11-100	-	700	-	2,49	54,4
	737	11-400	-	2800	-	0,62	54,4

\* Contact Enerpac for applications where operating pressure is less than 10% of pressure rating.

# Ultra-High Pressure Hand Pumps

## ▼ Optional Ultra-High Pressure Fittings and Tubings

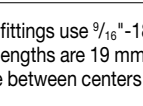
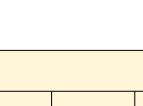
Description	Connection	Model Nr.
<b>2800 bar</b>		
<b>Gland Nut Plug</b>	 .38" cone	<b>43-001</b>
<b>Elbow</b>	 .38" cone	<b>43-200</b>
<b>Tee</b>	 .38" cone	<b>43-300</b>
<b>Gauge Tee</b>	 .38" cone side/ .25" cone gauge port	<b>43-301</b>
<b>Gauge Adaptor</b>	 .38" cone side/ .25" cone gauge port	<b>83-011</b>
<b>Coupling</b>	 .38" cone	<b>43-400</b>
<b>Cross</b>	 .38" cone	<b>43-600</b>
<b>Gland Nut with Sleeve</b>	 .38" cone	<b>43-701</b>
<b>Tubing</b>	 100 mm tube, O.D. .38" * 200 mm tube, O.D. .38" * 300 mm tube, O.D. .38" *	<b>45-116</b> <b>45-126</b> <b>45-136</b>
<b>700 bar only</b>		
<b>Adaptor</b>	 .38" F cone to 1/4" M NPTF	<b>41-146</b>
	 .38" F cone to 3/8" M NPTF	<b>41-166</b>
<b>Adaptor</b>	 .38" F cone to 1/4" F NPTF	<b>41-246</b>
	 .38" F cone to 3/8" F NPTF	<b>41-266</b>
<b>Adaptor</b>	 .38" M cone to 3/8" F NPTF	<b>41-366</b>

Note: .25" cone fittings use 9/16"-18 threads, 3/8" cone fittings use 3/4"-16 threads.  
\* Actual tubing lengths are 19 mm less than nominal size shown. These dimensions make distance between centers of valves and fittings multiples of 100 mm spaces.

## P 11 Series



Reservoir Capacity:  
**737 - 983 cm<sup>3</sup>**

Flow at Rated Pressure:  
**0,61 - 2,49 cm<sup>3</sup>/stroke**

Maximum Operating Pressure:  
**700 - 2800 bar**

Optional T-Series gauge and fitting

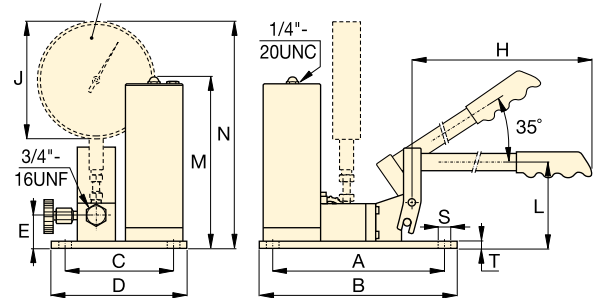

11-100, 11-400

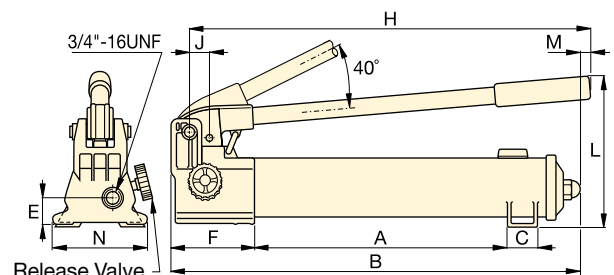

P-2282

Piston Stroke (mm)	Dimensions (mm)														Model Number
	A	B	C	D	E	F	H	J	L	M	N	S	T		
25,4	344	558	35	-	31	133	527	29	228	7	120	-	-	6,4	<b>P-2282</b>
19,8	240	266	151	177	45	-	635	162	114	237	314	7	9	10,0	<b>11-100</b>
19,8	240	266	151	177	45	-	635	162	114	237	314	7	9	10,0	<b>11-400</b>

▼ Shown: BP-122E



- Lightweight, compact design with integrated handle for maximum portability
- Dual power selection and variable speed for preferred flow and precise control
- With manual 3/2 valve (advance/retract) for use with single-acting cylinders and tools
- Heavy-duty 28 volt Lithium-Ion battery pack delivers constant fade-free power
- Immediate charging after use — a quick one hour charge
- Pump model includes two 3,0 Ampères-hour battery packs and quick charger.

▼ Take the battery pump anywhere without any power cords or air hoses.



## Portable Cordless Power Anywhere



### 28-Volt Lithium-Ion Battery

Heavy-duty construction with easy to operate latches. Fuel gauge LEDs show remaining charge.

Number of illuminated LEDs	Charge Remaining
4 ■■■■	100%-78%
3 ■■■	77%-56%
2 ■■	55%-34%
1 ■	33%-10%
Flashing	less than 10%



### G2535L Gauge

Minimize the risk of overloading and ensure long dependable service from your cordless pump.

Page: **128**



### Hoses

To ensure the integrity of your system, specify only genuine Enerpac hydraulic hoses.

Page: **120**



### Help Keep Our Environment Clean

Battery packs contain no cadmium. Enerpac encourages recycling.

# Battery Powered Hydraulic Pumps



## Battery Powered Pump

The BP-series cordless pump is best suited for small to medium size cylinders or hydraulic tools, or wherever portable cordless hydraulic power is needed.

Powerful for everyday use, its lightweight and ergonomic design are ideal for both, remote job sites or wherever a cord gets in the way.

The Lithium-Ion battery operates at peak performance under extreme conditions to get more work completed. The battery pack provides the power to run the cordless pump at maximum pressure for over six minutes.

Numerous applications are easily and safely performed using the cordless pump powered by the Lithium-Ion battery pack.\*

- 130 cuts of 9,5 mm (3/8 inch) reinforcing bar using the WHC-750 cutter
- 75 lifts with a WR-5 spreader
- Safely remove thirty M24 nuts using the NC-3241 nut splitter
- Lift loads multiple times using 5 to 100 ton jacks.

\* Actual number of cycles will depend on condition of tool, battery, and ambient conditions.



## BP Series



Reservoir Capacity:  
**1,9 - 3,8 litres**

Flow at Rated Pressure:  
**0,25 l/min**

Maximum Operating Pressure:  
**700 bar**

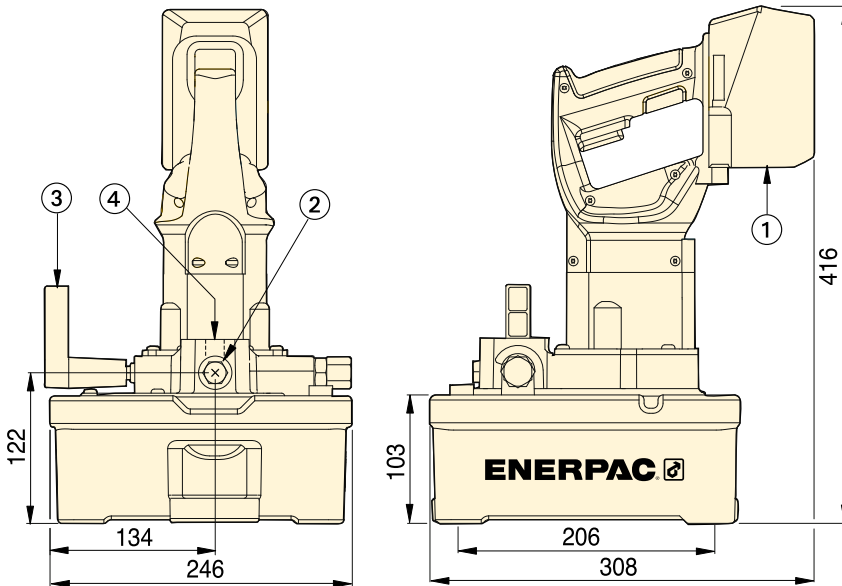

- ① 28-Volt Lithium-Ion battery
- ② 3/8"-18 NPTF oil outlet
- ③ 3-way, 2-position valve
- ④ 1/4"-18 NPTF gauge port

### SELECTION CHART

Pump Type (used with cylinder or tool)	Usable Oil Capacity (litres)	Model Number	Output Flow Rate (l/min)		Valve Type	Charger Voltage (VAC)	Weight (kg)
			14 bar	700 bar			
Single-Acting	1,9	BP-122E	1,9	0,25	3/2	230	9,6
	3,8	BP-124E	1,9	0,25	3/2	230	10,9
	1,9	BP-122	1,9	0,25	3/2	115	9,6
	3,8	BP-124	1,9	0,25	3/2	115	10,9

Sound level: 95 dBA at 3000 RPM.

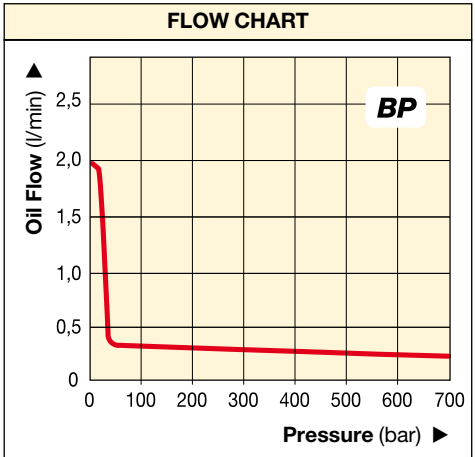

▼ Cordless power and simplicity for the toughest jobs: BP-122E battery pump used to operate an RCS-1002 low height cylinder. After lifting the load is mechanically supported by LPC-Series Cribbing Blocks.





# PU-Series, Economy Electric Pumps

▼ Shown: PUJ-1200E



- Lightweight and compact design: 11,8 to 18,6 kg
- Large easy-carry handle for maximum portability
- Two-speed operation reduces cycle times for improved productivity
- 230 VAC 50/60-cycle universal motor will operate under poor voltage supply
- 24 VAC remote motor control, 3 m length for operator safety
- Starts under full load
- High strength molded shroud, with integral handle, protects motor from contamination and damage.

▼ An Economy pump PUJ-1200E is used with an RC-2514 to reposition a stamping die to simplify maintenance.



## Heavy on Performance, Light on Weight



### Gauges

Minimize the risk of overloading and ensure long, dependable service from your equipment. For use with the Economy pump the **G-2535L** gauge and **GA-3** gauge adaptor are suggested.

For a full range of gauges, please refer to the System Components section.

Page: 128



### Hoses

Enerpac offers a complete line of high quality hydraulic hoses. To ensure the integrity of your system, specify only genuine Enerpac hydraulic hoses.

Page: 120



### Speed Chart

To determine how a specific pump will operate your cylinder, see the Pump-Cylinder Speed Chart in the 'Yellow Pages'.

Page: 249

Pump Type  (Used with cylinder)	Usable Oil Capacity  (litres)	Model Number*	Pressure Rating  (bar)	
			1 <sup>st</sup> stage	2 <sup>nd</sup> stage
Single-Acting	1,9	PUD-1100E	13	700
	3,8	PUD-1101E	13	700
	1,9	PUJ-1200E	13	700
	3,8	PUJ-1201E	13	700
	1,9	PUD-1300E	13	700
	3,8	PUD-1301E	13	700
Double-Acting	1,9	PUJ-1400E	13	700
	3,8	PUJ-1401E	13	700

\* For 115 volt applications replace 'E' suffix with 'B'.

\*\* Electric dump valve for auto-retract of cylinders.

# Economy Electric Pumps



## About the Economy Pump

The Economy pump is best suited to power small to medium size cylinders or hydraulic tools. Its lightweight and compact design make it ideal for applications which require easy transport of the pump. The universal motor works well on long extension cords or generator-driven electrical power supplies.

For further application assistance refer to the 'Yellow Pages'.

### PUD-1100 Series

- Provides advance-retract of single-acting cylinders
- Ideal for punching applications
- For applications not requiring load holding
- 3 m pendant controls motor and valve operation.

### PUD-1300 Series

- Provides advance-hold-retract of single-acting cylinders
- Ideal for applications requiring load-holding
- For applications requiring remote valve operations
- 3 m pendant controls motor and valve operation.

### PUJ Series

- Manual valves provide advance-hold-retract tool operation
- Available with 3- and 4-way valves for single or double-acting cylinders
- 3 m pendant controls the motor operation.



Page: 239

## PU Series



Reservoir Capacity:

**1,9 - 3,8 litres**

Flow at Rated Pressure:

**0,32 l/min**

Motor Size:

**0,37 kW**

Maximum Operating Pressure:

**700 bar**

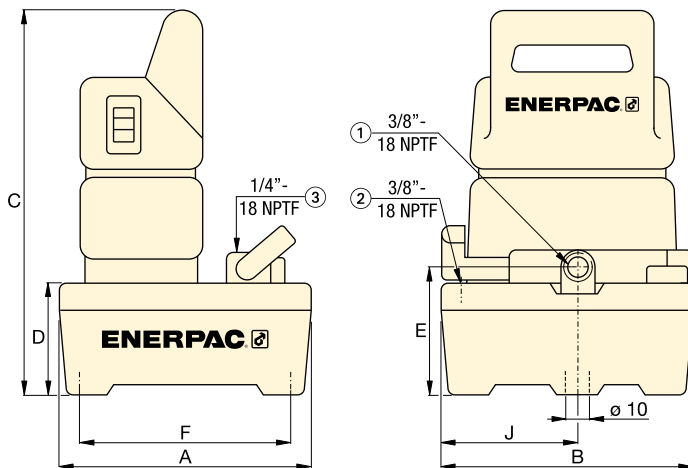

- ① Oil Outlet Port
- ② Tank Port
- ③ Gauge Port (PUJ-1200 and PUJ-1201 only)

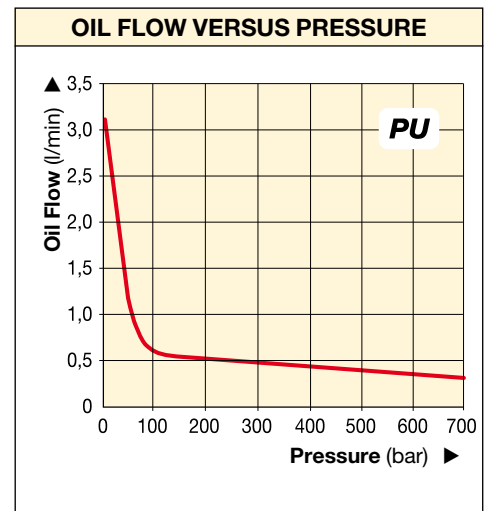

Output Flow Rate (l/min)		Valve Type	Valve Function	Current Draw (Amps)	Motor Voltage (VAC)	Sound Level (dBA)	Dimensions (mm)						Weight (kg)	Model Number *	
1st stage	2nd stage						A	B	C	D	E	F			J
3,31	0,32	Dump**	Advance/Retract	3,2	230	85	244	244	362	101	119	203	133	11,8	PUD-1100E
3,31	0,32			3,2	230	85	368	309	373	105	130	323	142	17,2	PUD-1101E
3,31	0,32	3/2 manual	Advance/ Hold/Retract	3,2	230	85	244	244	362	101	119	203	133	10,0	PUJ-1200E
3,31	0,32			3,2	230	85	368	309	373	105	130	323	142	15,4	PUJ-1201E
3,31	0,32	3/2 solenoid	Advance/ Hold/Retract	3,2	230	85	244	244	362	101	119	203	133	12,0	PUD-1300E
3,31	0,32			3,2	230	85	368	309	373	105	130	323	142	17,5	PUD-1301E
3,31	0,32	4/3 manual	Advance/ Hold/Retract	3,2	230	85	244	244	362	101	119	203	133	13,2	PUJ-1400E
3,31	0,32			3,2	230	85	368	309	373	105	130	323	142	18,6	PUJ-1401E

▼ Shown: PEJ-1401E



- Two-speed operation reduces cycle times for improved productivity
- Powerful 0,37 kW induction motor is submerged in the oil reservoir to run cooler, protect the motor, simplify the pump interface, save space and reduce noise
- Large 5,5 litres reservoir allows operation of a wide range of cylinders
- 24 VDC remote pendant control on certain models for safer operation
- Externally adjustable relief valve allows control of operating pressure without opening the pump
- 40-micron internal return line filter keeps oil clean, promoting longer pump life
- Full length side tube for easy monitoring of oil level.



◀ *The Remote Jog Model of the Submerged Pump simplifies repair on this construction crane.*

## Best Performance for Mid-Range Cylinders and Tools

### ▼ SELECTION CHART

For more technical information see next page.

#### 5 BASIC PUMP TYPES

Select the model that suits your application. For special requirements see **page 83** or contact your Enerpac office.

#### **PED Series: with Dump Valve**

- Ideal for punching, crimping and cutting
- For use when load holding is not required
- Control pendant with 3 m cord controls valve and motor

#### **PEM Series: with Manual Valve**

- Ideal choice for most applications
- Manual valve control, for both single-acting and double-acting applications
- Manual motor control

#### **PER Series: with Solenoid Valve**

- Ideal for production and lifting
- All valves are 3 position for Advance-Hold-Retract
- Control pendant with 3 m cord for remote valve operation

#### **PEJ Series: with Remote Jog**

- For light production and lifting applications
- Manual valve control for single-acting or double-acting cylinders
- Control pendant with 3 m cord for remote motor operation

#### **PES Series: with Pressure Switch**

- Designed for continuous pressure applications, such as clamping, workholding and testing
- All versions include manual valves for directional control

\* See the Valve Section in this catalog for technical information on valve types.

# Submerged Electric Pumps



## PE-Series Submerged Pump Application

The Submerged pump is best suited to power small to medium size cylinders or hydraulic tools, or whenever quiet, intermittent duty cycle is needed.

With its low sound level and the addition of the optional oil cooler, the Submerged pump is suited to light production work as well.

Its lightweight and compact design also make it ideal for applications which require some transport of the pump.

For further application assistance see the 'Yellow Pages' or contact your local Enerpac office.

Page: 239

## PE Series



Reservoir Capacity:

**5,5 litres**

Flow at Rated Pressure:



**0,27 l/min**

Motor Size:

**0,37 kW**

Maximum Operating Pressure:

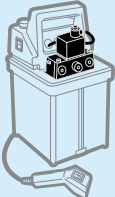
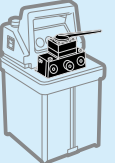
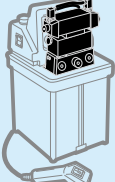
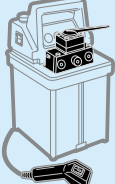
**700 bar**

Pump Type	Used with Cylinder	Valve Function	Valve Type*	Usable Oil Capacity (litres)	Model Number	 (kg)
	Single-Acting	Advance/Retract	Dump	5,5	<b>PED-1001E</b>	24,9
	Single-Acting	Advance/Retract	Manual, 3-way, 2-position	5,5	<b>PEM-1201E</b>	24,0
	Single-Acting	Advance/Hold/Retract	Manual, 3-way, 3-position	5,5	<b>PEM-1301E</b>	24,0
	Double-Acting	Advance/Hold/Retract	Manual, 4-way, 3-position	5,5	<b>PEM-1401E</b>	24,0
	Single-Acting	Advance/Hold/Retract	Solenoid, 3-way, 3-position	5,5	<b>PER-1301E</b>	29,5
	Double-Acting	Advance/Hold/Retract	Solenoid, 4-way, 3-position	5,5	<b>PER-1401E</b>	29,5
	Single-Acting	Advance/Retract	Manual, 3-way, 2-position	5,5	<b>PEJ-1201E</b>	24,9
	Single-Acting	Advance/Hold/Retract	Manual, 3-way, 3-position	5,5	<b>PEJ-1301E</b>	24,9
	Double-Acting	Advance/Hold/Retract	Manual, 4-way, 3-position	5,5	<b>PEJ-1401E</b>	24,9
	Single-Acting	Advance/Retract	Manual, 3-way, 2-position	5,5	<b>PES-1201E</b>	28,1
	Double-Acting	Advance/Hold/Retract	Manual, 4-way, 3-position	5,5	<b>PES-1401E</b>	28,1



# PE-Series, Submerged Electric Pumps

◀ For full features see previous page.

SUBMERGED PUMP PERFORMANCE							
Motor Size (kW)	Pressure Rating (bar)		Output Flow Rate at 50 Hz (l/min)		Motor Electrical Specifications * (Amps @ Volts-Ph-Hz)	Sound Level (dBA)	Relief Valve Adjustment Range (bar)
	1 <sup>st</sup> stage	2 <sup>nd</sup> stage	1 <sup>st</sup> stage	2 <sup>nd</sup> stage			
0,37	70	700	2,0	0,27	13 @ 115-1-50/60 6,75 @ 230-1-50/60	62-70	70-700

\* At full load. See ordering matrix footnote for frequency notations.

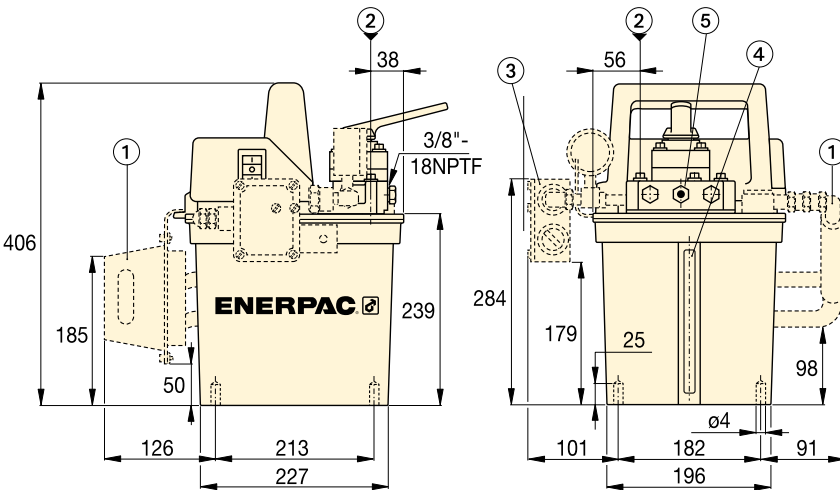

- ① Heat Exchanger (optional for all models)
- ② Fill Port
- ③ Pressure Switch (PES-series, optional for other models)
- ④ Oil Level Indicator
- ⑤ Adjustable relief valve

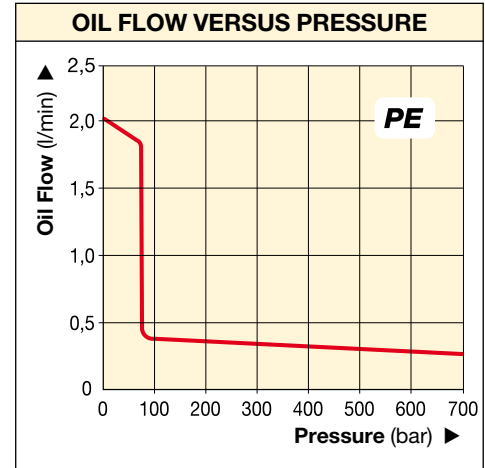

### Speed Chart

To determine how a specific pump will operate your cylinder, see the Pump-Cylinder Speed Chart in the 'Yellow Pages'.

Page: **249**



◀ This PED-1001E Submerged pump quickly and quietly powers a hydraulic nut cutter in this bucket maintenance application.

# Submerged Electric Pumps

## CUSTOM BUILD YOUR SUBMERGED PUMP

If the Submerged Pump that would best fit your application cannot be found in the chart on page 81, here you can easily build your custom submerged pump.

▼ This is how a Submerged Pump Model Number is built up:

<b>P</b>	<b>E</b>	<b>M</b>	<b>-</b>	<b>1</b>	<b>3</b>	<b>01</b>	<b>E</b>
1	2	3		4	5	6	7
Product Type	Motor Type	Pump Type		Pump Series	Valve Type	Reservoir Size	Motor Voltage

### 1 Product Type

**P** = Pump

### 2 Motor Type

**E** = Electric Motor

### 3 Pump Type

**D** = Dump

**J** = Jog

**M** = Manual

**R** = Remote (Solenoid) <sup>1)2)</sup>

**S** = Pressure Switch

### 4 Pump Series

**1** = 0,37 kW, 700 bar

### 5 Valve Type

**0** = No valve (PER only)

**1** = Dump

**2** = 3-way, 2-position, normally open

**3** = 3-way, 3-position, tandem center

**4** = 4-way, 3-position, tandem center

**5** = Modular solenoid valve (PER only)

### 6 Reservoir Capacity

**01** = 5,5 litres

### 7 Motor Voltage and Heat Exchanger

**B** = 115 V, 1 Ph, 50/60 Hz <sup>1)</sup>

**D** = 115 V, 1 Ph, 50/60 Hz <sup>1)</sup>

with Heat Exchanger

**E** = 230 V, 1 Ph, 50/60 Hz <sup>2)</sup>

**F** = 230 V, 1 Ph, 50/60 Hz <sup>2)</sup>

with Heat Exchanger

**I** = 230 V, 1 Ph, 60 Hz

<sup>1)</sup> Solenoid valves operate only at 60 Hz. Can run on 50 Hz with manual valves.

<sup>2)</sup> Solenoid valves operate only at 50 Hz. Can run on 60 Hz with manual valves.

### Ordering Example

#### Model Number: PER-1301E

The PER-1301E is a 0,37 kW, 700 bar, submerged electric pump, with 5,5 litres usable oil capacity, a 3-way, 3-position, remote solenoid valve and a 230 V, 1 Phase, 50/60 Hz motor.

## PE Series



Reservoir Capacity:

**5,5 litres**

Flow at Rated Pressure:

**0,27 l/min**

Motor Size:

**0,37 kW**

Maximum Operating Pressure:

**700 bar**



### Hoses

Enerpac offers a complete line of high quality hydraulic hoses. To ensure the integrity of your system, specify only genuine Enerpac hydraulic hoses.

Page: 120



### Gauges

Minimize the risk of overloading and ensure long, dependable service from your equipment. Refer to the System Components section for a full range of gauges.

Page: 128

# Z-Class Enerpac Power Pumps

Introducing the *Z-Class* power pumps from Enerpac – pumps that run cooler, use less electricity and are easy to service.

Enerpac has used the latest metallurgical, bearing and seal technologies to produce a pump whose features and benefits far surpass the electric pumps that are available today. By reducing the number of moving parts, improving flow dynamics and decreasing friction, *Z-Class* pumps will stay on the job longer, require less energy to operate and when needed, have lower service costs.

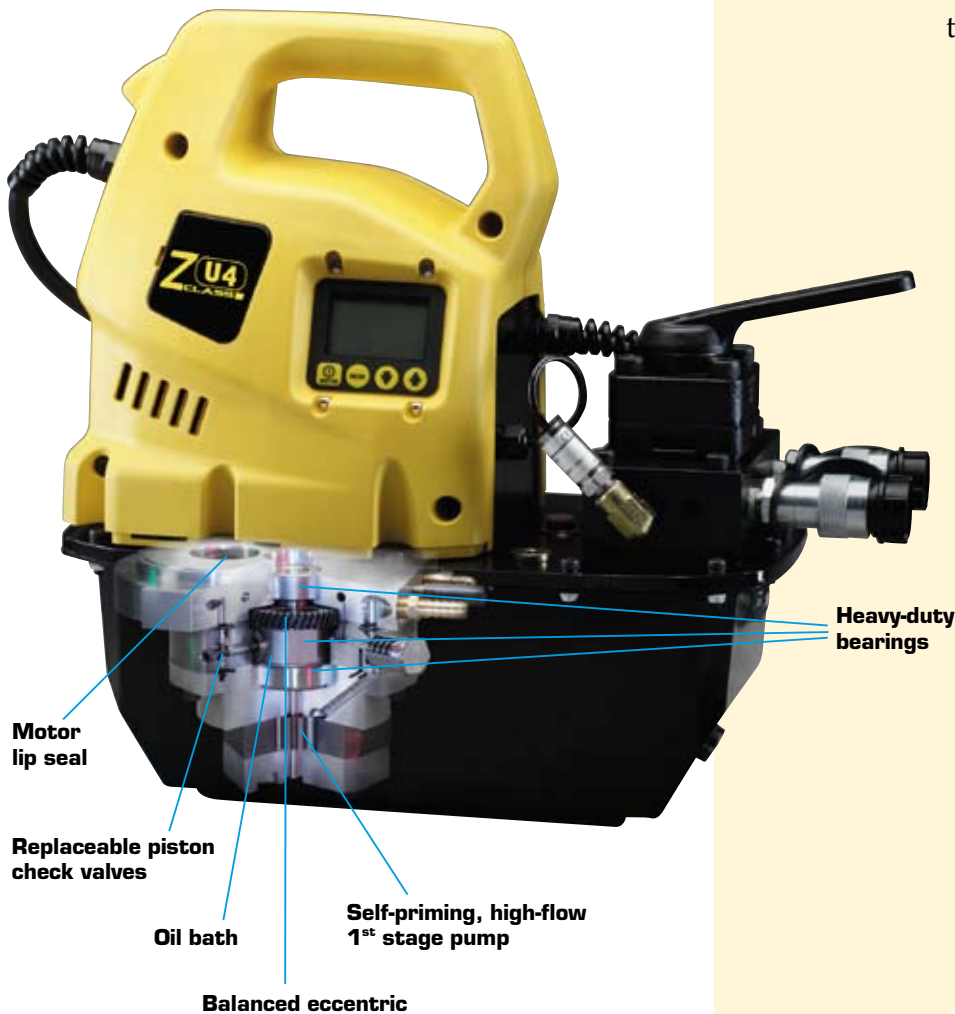

*Z-Class* power pumps from Enerpac – simply the best pump you will ever use.



**Z** Tough.  
Dependable.  
Innovative.  
**CLASS**

# Z-Class, An Innovation in Pump Design

## Z-Class Pumping Element – The Heart of Your Hydraulic System

**Highly efficient design** provides increased flow rates, reduced heat generation and a decrease in power consumption. This means improved tool speed and increased service life – which results in higher productivity and lower operating costs.

**Heavy-duty bearings** extend pump life by reducing friction, reducing surface-loading and lowering bearing stresses.

**Pump cavity oil bath** extends pump life by reducing heat, improving lubrication and reducing wear.

**Self-priming, high-flow 1st stage pump** increases pump performance by super-charging the 2nd stage piston pump – improving oil flow in both hot and cold weather operation.

**Balanced rotating components reduce vibration** creating a smoother running pump – reducing wear, friction and sound levels.

**Replaceable piston check-valves** increase service life of major pump components.

**Ergonomic low-voltage pendant** features sealed switches and operates at 15 V for improved operator safety.

### Z-Class factory options & accessories

Extensive list of accessories including heat exchanger, roll cage, skid bar, pressure transducer, return line filter and level and temperature switches, allow complete pump control over a wide range of industrial applications.

### Z-Class power pumps for your application

Available in one flow range for universal motor and eight flow ranges for induction motor. Choose from single or two-stage models to provide the optimum cylinder and tool performance for almost any industrial application.

### Back-lit LCD on select Z-Class pumps

- pump usage information, hour and cycle counts
- low-voltage warning and recording
- offers self-test and diagnostic capabilities
- information displayed in 6 languages
- pressure read-out (when used with the optional pressure transducer)
- adjustable trigger pressure setting (when used with the optional pressure transducer).



Back-lit LCD available on ZU and ZE-Series Electric Pumps. ▶



### ZU-Series Pump Applications

- **Mobile:** when frequent pump transport is required and/or on remote locations
- **Universal motor:** 1-phase, runs well under poor voltage supply, using generator power supply or using long extension cord
- **Duty-cycle:** for intermittent applications
- **Cylinders and tools:** for medium to large size single and double-acting applications and high speed
- **Pump speed:** two stage pump unit.



### ZE-Series Pump Applications

- **Stationary:** when pump remains in one location
- **Induction motor:** 1 and 3-phase for high cycle usage
- **Duty-cycle:** for heavy-duty, extended cycle application
- **Cylinders and tools:** for medium to large size single and double-acting applications and high speed
- **Pump speed:** single or two stage pump unit.

Oil Flow Rate at 700 bar (l/min)	Z-Class Pump Series *	Electric Motor Power (kW)	Air Motor-Consumption (l/min air)	Gasoline Engine Power (kW)	Page:
0,55	ZE3	0,75	–	–	92
0,82	ZE4(T)	1,12	–	–	92, 208
1,00	ZU4(T)	1,25	–	–	86, 204
1,30	ZA4(T)	–	2840	–	106, 212
1,60	ZG5	–	–	4,8	110
1,64	ZE5(T)	2,24	–	–	92, 208
2,73	ZE6	5,60	–	–	92
3,30	ZG6	–	–	9,7	112

\* ZA4T, ZU4T, ZE4T and ZE5T-Series are Torque Wrench Pumps.



# ZU4-Series, Portable Electric Pumps

▼ Shown from left to right: ZU4304ME, ZU4420SE-H, ZU4304PE-K



**Z** Tough.  
Dependable.  
Innovative.  
**CLASS**

 **ZU4-Series Features and Options**  
For special requirements see factory installed features and options.

Page: **88**

- High-efficiency two-speed pump design – higher oil flow and bypass pressure
- Powerful 1,25 kW universal electric motor provides high power-to-weight ratio and excellent low-voltage operating characteristics
- High-strength, moulded composite shroud protects motor and electronics, while providing an ergonomic, non-conductive handle for easy transport.

**Pro-Series models only**

- \* Back-lit LCD readout provides pressure display and a number of diagnostics and readout capabilities never offered on a portable pump before
  - pump usage information, hour and cycle counts
  - self-test, diagnostic and read-out capabilities
  - pressure readout and auto-mode pressure settings.



◀ *Designed to be tough, the ZU4-Series with steel reservoirs will take the abuse of today's construction sites. The ZU4908JE is the ideal pump for post tensioning applications. For post tensioning tools see page 182.*

▼ **COMMON PUMP MODELS**

For technical information and other options see next page.

<b>BASIC PUMP TYPES</b>	
Select the model that suits your application. For special requirements contact your Enerpac office.	
<b>Manual Valve</b>	
<ul style="list-style-type: none"> <li>• Ideal choice for most applications.</li> <li>• Manual valve control, for single-acting or double-acting applications.</li> <li>• Motor control on shroud.</li> </ul>	
<b>Manual Valve with Pendant *</b>	
<ul style="list-style-type: none"> <li>• For light production and lifting applications.</li> <li>• Manual valve for single- or double-acting cylinders.</li> <li>• Manual valve with power seat (VM43LPS), ideal for post-tensioning applications.</li> </ul>	
<b>Dump Valve *</b>	
<ul style="list-style-type: none"> <li>• Ideal for punching, crimping and cutting.</li> <li>• For use when load-holding is not required.</li> </ul>	
<b>Solenoid Valve *</b>	
<ul style="list-style-type: none"> <li>• Ideal for lifting applications and where remote control is required.</li> <li>• Motor runs continuously on pumps with VE33 and VE43 valves. With VE32 valve, motor only runs during the advance function, while holding and retracting, the motor is off.</li> </ul>	

\* Low-voltage control pendant with 3m. cord controls valve and motor.

# ZU4-Series, Electric Pumps



## Z-Class – A Pump For Every Application

Patented Z-Class pump technology provides high by-pass pressures for increased productivity – important in applications using long hose runs and high pressure-drop circuits, like heavy lifting or certain double-acting tools.

Enerpac ZU4 Hydraulic Pumps are built to power small to large-sized cylinders or hydraulic tools, or wherever high-speed, intermittent duty, remote hydraulic power is needed.

### Classic Electric Pump

- The Classic has traditional electro-mechanical components (transformers, relays and switches) in place of solid-state electronics.

The Classic delivers durable, safe and efficient hydraulic power for demanding markets like construction, post-tensioning and foundation repair.

### Standard Electric Pump

- For applications that do not require digital display features of the Premium Pump. Available in all manual or jog versions.

### Pro Electric Pump

- Digital (LCD) display features a built-in hour meter and shows self-diagnostic, cycle-count and low voltage warning information.

Pressure can also be displayed when the pump is equipped with an optional pressure transducer.



## ZU4 Series



Reservoir Capacity:

**4 - 40 litres**

Flow at Rated Pressure:

**1,0 l/min**

Motor Size:

**1,25 kW**

Maximum Operating Pressure:

**700 bar**

Pump Type	Used with Cylinder		Valve Function			Valve Type <sup>1)</sup>	Pump Control	Useable Oil Capacity (litres)	Model Number 230 V - 1 phase - 50 Hz <sup>2)</sup>			Pro Electric Weight <sup>3)</sup> (kg)
									Classic Electric	Standard (STD) Electric	Pro Electric (incl. LCD)	
	●		●		●	VM32	Manual	4	ZU4204RE	ZU4204ME	ZU4204LE	27
	●		●		●	VM32	Manual	8	ZU4208RE	ZU4208ME	ZU4208LE	32
	●		●	●	●	VM33	Manual	8	ZU4308RE	ZU4308ME	ZU4308LE	32
	●		●	●	●	VM33	Manual	20	ZU4320RE	ZU4320ME	ZU4320LE	50
		●	●	●	●	VM43	Manual	8	ZU4408RE	ZU4408ME	ZU4408LE	32
		●	●	●	●	VM43	Manual	20	ZU4420RE	ZU4420ME	ZU4420LE	50
	●		●		●	VM32	Remote (Man.)	4	ZU4204PE	ZU4204JE	ZU4204KE	27
	●		●		●	VM32	Remote (Man.)	8	ZU4208PE	ZU4208JE	ZU4208KE	32
	●		●		●	VM32	Remote (Man.)	20	ZU4220PE	ZU4220JE	ZU4220KE	50
	●		●	●	●	VM33	Remote (Man.)	8	ZU4308PE	ZU4308JE	ZU4308KE	32
		●	●	●	●	VM43	Remote (Man.)	8	ZU4408PE	ZU4408JE	ZU4408KE	32
		●	●	●	●	VM43	Remote (Man.)	20	ZU4420PE	ZU4420JE	ZU4420KE	50
	●		●		●	VE32D	Remote	4	N/A	N/A	ZU4104DE	29
	●		●		●	VE32D	Remote	8	N/A	N/A	ZU4108DE	33
	●		●		●	VE32D	Remote	20	N/A	N/A	ZU4120DE	51
						-	-	-	-	-	-	-
						-	-	-	-	-	-	-
						-	-	-	-	-	-	-
	●		●		●	VE32	Remote	4	N/A	N/A	ZU4204SE	29
	●		●		●	VE32	Remote	8	N/A	N/A	ZU4208SE	33
	●		●	●	●	VE33	Remote	8	N/A	N/A	ZU4308SE	39
		●	●	●	●	VE43	Remote	8	N/A	N/A	ZU4408SE	39
		●	●	●	●	VE43	Remote	20	N/A	N/A	ZU4420SE	56
						-	-	-	-	-	-	-
						-	-	-	-	-	-	-
						-	-	-	-	-	-	-

<sup>1)</sup> See valves section for technical information on valve types. <sup>2)</sup> See custom order matrix on page 91 for other voltage options.

<sup>3)</sup> Subtract 1,4 kg for Standard (STD) Electric models.



## Pressure Transducer \*

- More durable than analog gauges (against mechanical and hydraulic shock)
- More accurate than analog gauges (0,5% full scale of pump)
- Calibration can be fine tuned for certification
- “Set pressure” feature turns off motor at user defined pressure (or shifts valve to neutral on models with VE33/VE43 valves)
- Display pressure in bar, psi or MPa.

\* Requires LCD Electric

Accessory Kit Model Number	Adjustable Pressure Range (bar)	Switch-point repeatability	Dead-band (bar)
ZPT-U4 *	3,5 - 700	± 0,5%	3,5

\* Add suffix **T** for factory installation.

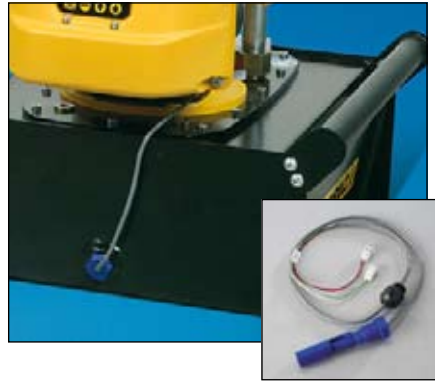

## Level/Temperature Switch

- Ensures feedback on pump oil level and temperature
- Drop-in design allows for easy installation to pump reservoir
- Plugs directly into pump electrical enclosure
- Built-in thermal sensing shuts off pump when unsafe operating temperature is reached
- Oil level switch shuts down pump before oil reaches an unsafe operating level.

Model Number	Operating Temperature (°C)	Maximum Pressure (bar)	 (kg)
ZLS-U5 *	5-110	10	0,1

\* Add suffix **L** for factory installation.



## Hoses

Enerpac offers a complete line of high-quality hydraulic hoses. To ensure the integrity of your system, specify only Enerpac hydraulic hoses.

Page: 120



## Gauges

Minimize the risk of overloading and ensure long, dependable service from your equipment. Refer to the System Components section for a full range of gauges.

Page: 128



## Foot Switch

- Hands-free remote control on solenoid dump and 3-position valves
- With 3 metres cord.

Accessory Kit No.	Can be used on ZU4-Series Pumps with
ZCF-2 *	Solenoid VE-Series valves

\* Add suffix **U** for factory installation.



## Roll Cage

- Protects pump
- Provides greater pump stability.

Accessory Kit Number	Fits on reservoir
ZRC-04 *	4 and 8 litres <sup>1)</sup>
ZRC-04H *	4 and 8 litres <sup>2)</sup>
ZRB-10 *	10 litres
ZRB-20 *	20 litres
ZRB-40 *	40 litres

\* Add suffix **R** for factory installation.

<sup>1)</sup> Without heat exchanger

<sup>2)</sup> With heat exchanger



## Skid Bar

- Provides easy two-hand lift
- Provides greater pump stability on soft or uneven surfaces.

Accessory Kit Modelnr.	Fits on reservoir	 (kg)
SBZ-4 *	4 and 8 l without heat exchanger	2,2
SBZ-4L *	4 and 8 l with heat exchanger	3,2

\* Add suffix **K** for factory installation.



# ZU4-Series, Options & Accessories



## ZU4-Series Options

Accessory Kits can be installed by the customer.

See chart below for all possible options on ZU4-Series pumps:

- Classic Electric,
  - Standard (STD) Electric (no LCD)
  - Pro Electric (with LCD).
- Refer to page 91 for ordering matrix.

ZU4-Series Options	Factory Installed			Accessory Kits		
	Classic Electric	Standard Electric	Pro Electric	Classic Electric	Standard Electric	Pro Electric
Return Line Filter	F	F	F	ZPF	ZPF	ZPF
Skid Bar <sup>1)</sup>	K	K	K	SBZ	SBZ	SBZ
Roll Cage	R	R	R	ZRC	ZRC	ZRC
Heat Exchanger	H	H	H	ZHE	ZHE	ZHE
1000 bar Pressure Gauge	G	G	G	G	G	G
Pressure Transducer	-	-	T	-	-	ZPT-U4
Level/Temperature Switch	-	-	L	-	-	ZLS-U5
Foot Switch	-	-	U	-	-	ZCF-2

<sup>1)</sup> Skid Bar not in combination with Roll Cage.

## ZU4 Series



Reservoir Capacity:

**4 - 40 litres**

Flow at Rated Pressure:

**1,0 l/min**

Motor Size:

**1,25 kW**

Maximum Operating Pressure:

**700 bar**



### 25 Micron Return Line Filter

- Removes contaminants from return oil flow
- By-pass valve prevents damage if filter is dirty
- With maintenance indicator.

Accessory Kit Modelnr.	Maximum Pressure (bar)	Maximum Oil Flow (l/min)	By-pass Setting (bar)
ZPF *	13,8	45,4	1,7

\* Add suffix **F** for factory installation.



### Heat Exchanger

- Removes heat from by-pass oil to provide cooler operation
- Stabilizes oil viscosity, increasing oil life and reduces wear of pump and other hydraulic components.

Accessory Kit Nr.	Can be used on	(kg)
ZHE-U115 *	115 V pumps	4,1
ZHE-U230 *	230 V pumps	4,1

\* Add suffix **H** for factory installation.



### Heat Exchanger

Can be factory installed on ZU4-Series Classic, Standard Electric and Pro Electric models.

- Extends system life.
- Stabilizes oil temperature at a maximum of 54 °C at 21 °C ambient temperature.

Do not exceed maximum oil flow and pressure ratings. Heat exchanger is not suitable for water-glycol or high water based fluids.

Thermal Transfer *		Maximum pressure	Maximum oil flow	Voltage
Btu/h	kJoule	(bar)	(l/min)	(VDC)
900	950	20,7	26,5	12

\* At 1,9 l/min at 21 °C ambient temperature.



# ZU4, Specifications and Dimensions

ZU4-SERIES PERFORMANCE									
Motor Size (kW)	Output Flow Rate at 50 Hz (l/min)				Motor Electrical Specifications (volts-ph-Hz)	Sound Level (dBA)	Relief Valve Adjustment Range (bar)		
	7 bar	50 bar	350 bar	700 bar					
1,25	11,5	8,8	1,2	1,0	115-1-50/60 230-1-50/60	85-90	140-700		

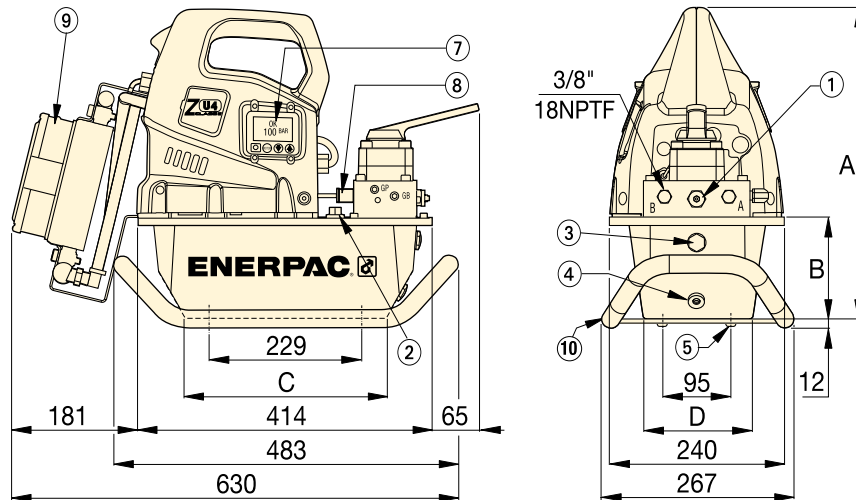
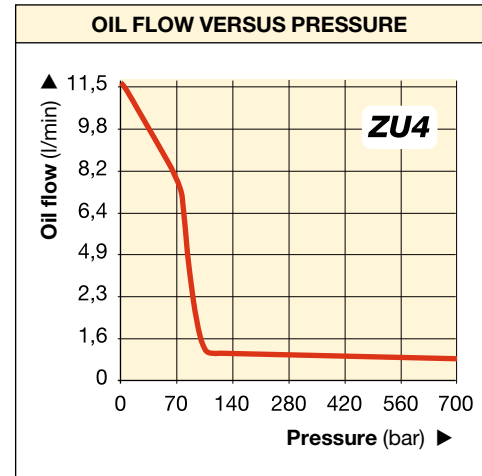

ZU4-Series with 4 and 8 litres reservoirs

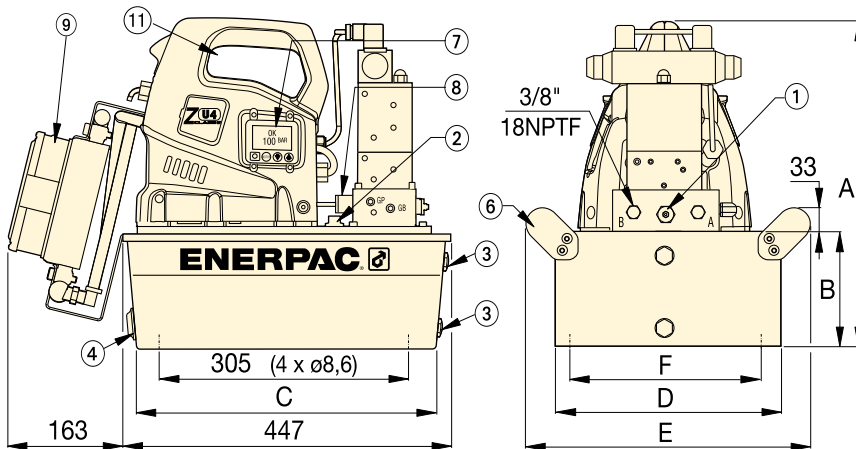

ZU4-Series with 10, 20 and 40 litres reservoirs  
(left view shown without side handle)

3/8"-18 NPTF Advance and Retract Ports

- ① User adjustable relief valve
- ② Oil fill port SAE #10 7/8"-14 UNF-2B
- ③ Oil level sight gauge
- ④ Oil drain 1/2" NPTF
- ⑤ M8, 12 mm deep
- ⑥ Handles on all 10, 20 and 40 litres reservoirs.

Options (see chart on page 89):

- ⑦ Back-lit LCD Electric
- ⑧ Pressure transducer
- ⑨ Heat Exchanger
- ⑩ Skid Bar  
Fits 4 and 8 litres reservoirs
- ⑪ Handle guard installed on all 10, 20 and 40 litres reservoirs
- ⑫ Reservoir handles (not shown) included on all 10, 20 and 40 litres reservoirs.



◀ Portable power pump with increased output flow and extended brush life increase productivity for post-tensioning applications.

Pump Dimensions (mm)						
Usable Reservoir Capacity (liter)	A	B	C	D	E	F
4	424	142	279	152	-	-
8	424	142	279	206	-	-
10	439	157	413	305	384	279
20	465	180	413	422	500	396
40	551	269	399	503	576	480

# ZU4-Series, Pump Ordering Matrix

## CUSTOM BUILD YOUR ZU4-SERIES PUMP

If the ZU4-Series pump that would best fit your application cannot be found in the chart on page 86, you can easily build your custom ZU4-Series pump here.

▼ This is how a ZU4-Series pump model number is built up:

<b>Z</b>	<b>U</b>	<b>4</b>	<b>1</b>	<b>04</b>	<b>D</b>	<b>E</b>	<b>-</b>	<b>H</b>	<b>K</b>	<b>T</b>
1	2	3	4	5	6	7	8			
Product Type	Motor Type	Flow Group	Valve Type	Reservoir Size	Valve Operation	Voltage	Options and Accessories			

### 1 Product Type

**Z** = Pump Series

### 2 Motor Type

**U** = Universal electric motor

### 3 Flow Group

**4** = 1,0 l/min @ 700 bar

### 4 Valve Type (see page 114-115 for more details)

- 1 Dump (VE32D)
- 2 3 way/2 position manual or electric (VM32 or VE32)
- 3 3 way/3 position manual or electric (VM33 or VE33)
- 4 4 way/3 position manual or electric (VM43 or VE43)
- 6 3 way/3 position locking manual w/po check (VM33-L)
- 7 3 way/2 position manual or electric (VM22)
- 8 4 way/3 position locking manual w/po check (VM43-L)
- 9 4 way/3 position manual w/power seating (VM43-LPS)

### 5 Reservoir Size (useable capacity)

- 04** = 4 litres
- 08** = 8 litres
- 10** = 10 litres <sup>1)</sup>
- 20** = 20 litres <sup>1)</sup>
- 40** = 40 litres <sup>1)</sup>

<sup>1)</sup> reservoir includes side handles.

### 6 Valve Operation

- D** = Dump (solenoid valve w/pendant and LCD Electric)
- J** = Jog (manual valve w/pendant and Standard Electric (i.e. w/o LCD)
- K** = Jog (manual valve w/pendant and LCD Electric)
- L** = Manual valve w/LCD Electric (w/o pendant)
- P** = Manual valve w/pendant and classic electric (i.e. w/o LCD)
- R** = Manual valve w/Classic electric (i.e. w/o LCD) [w/o pendant]
- M** = Manual valve w/Standard Electric (i.e. w/o LCD) [w/o pendant]
- S** = Solenoid valve w/pendant and LCD Electric

### 7 Voltage

- B** = 115V, 1 ph, 50/60Hz
- E** = 208-240V, 1 ph, 50/60 Hz (w/European plug and CE EMC compliant)
- I** = 208-240V, 1 ph, 50/60 Hz (w/NEMA 6-15 plug)

### 8 Options and Accessories (see page 89 for possibilities)

- F** = Filter
- G** = 0-1000 pressure bar (63,5 mm)<sup>1)</sup>
- H** = Heat exchanger
- K** = Skid Bar (4 and 8 litres reservoirs only)
- L** = Level/temperature switch <sup>2)</sup><sup>3)</sup>
- N** = No reservoir handles (includes lifting eyes)
- R** = Roll Cage
- T** = Pressure transducer <sup>2)</sup>
- U** = Foot switch

- <sup>1)</sup> Pressure gauge not available on pump models with pressure transducer
- <sup>2)</sup> These options require Pro Electric
- <sup>3)</sup> Not available on 4 and 8 litres reservoirs

## ZU4 Series



Reservoir Capacity:

**4 - 40 litres**

Flow at Rated Pressure:

**1,0 l/min**

Motor Size:

**1,25 kW**

Maximum Operating Pressure:

**700 bar**



### Speed Chart

To determine how a specific pump will operate your cylinder, see the Pump-Cylinder Speed Chart in the 'Yellow Pages'.

Page: **249**



### Ordering Example

**Model Number:**  
**ZU4408DE-HKT**

ZU4408DE-HKT is a Pro Electric model pump with LCD, 1,0 l/min oil flow at 700 bar, pump with a dump valve, an 8 liter reservoir, operates on 230V, heat exchanger, pressure transducer and skid bar.



### Torque Wrench Pumps and Hoses

Enerpac system matched air and electric torque wrench pumps provide control to operate hydraulic torque wrenches.

Page: **202**

# ZE-Series, Electric Pumps

▼ Shown from left to right: ZE3304ME-K, ZE4110DE-FHR



## Z CLASS

### The New Standard for Industrial Applications



#### Oil Level Glass

All ZE-Series pumps have an oil sight glass and steel reservoirs. Full sight oil level glass on 10, 20 and 40 litres reservoirs, oil level indicators on 4 and 8 litres reservoirs.

PUMP CONFIGURATIONS		Pump Type	Used with Tool or Cylinder		Valve Function <sup>1)</sup>			Valve <sup>1)</sup> Model Number	Useable Oil Capacity	
For options and other model numbers see ordering matrix or contact your Enerpac office. (For Z-Class pumps with air motor see ZA-series pumps on page 106).									(litres)	
<b>No Valve, without Electric Box <sup>2)</sup> or LCD</b> <ul style="list-style-type: none"> <li>For remote valves or pump mounting Enerpac VM-series valves</li> <li>For remote valve mounting order BSS1090 high pressure connecting plate.</li> </ul>								4		
								10		
								20		
								40		
MANUAL VALVE CONTROL	<b>With Manual Valve, without Electric Box or LCD</b> <ul style="list-style-type: none"> <li>Ideal choice for most application</li> <li>Manual valve control, for single and double-acting applications</li> <li>Manual motor control</li> <li>On/Off switch on 1-phase electric motor.</li> </ul>		●	-	●	-	●	VM32	4	
			●	-	●	●	●	VM33	8	
			●	-	●	●	●	VM33L	10	
			-	●	●	●	●	VM43	20	
			-	●	●	●	●	VM43L	40	
	MANUAL VALVE CONTROL	<b>With Manual Valve, with Electric Box and LCD</b> <ul style="list-style-type: none"> <li>For single-acting or double-acting applications</li> <li>On/off switch on 1-phase electric motor</li> <li>All options available.</li> </ul>		●	-	●	-	●	VM32	4
●				-	●	-	●	VM32	8	
●				-	●	●	●	VM33	10	
●				-	●	●	●	VM33L	10	
-				●	●	●	●	VM43	20	
-				●	●	●	●	VM43L	40	
REMOTE VALVE CONTROL	<b>With Solenoid Dump Valve, with Electric Box and LCD</b> <ul style="list-style-type: none"> <li>Ideal for punching, crimping and cutting</li> <li>For use when load holding is not required</li> <li>Push-button pendant <sup>3)</sup> controls valve and motor</li> <li>All options available.</li> </ul>		●	-	●	-	●	VE32D	4	
			●	-	●	-	●	VE32D	8	
			●	-	●	-	●	VE32D	10	
			●	-	●	-	●	VE32D	20	
			●	-	●	-	●	VE32D	40	
	REMOTE VALVE CONTROL	<b>With Solenoid 3-position Valve, with Electric Box and LCD</b> <ul style="list-style-type: none"> <li>Ideal for production and lifting applications</li> <li>3-position valves (advance/hold/retract)</li> <li>Push-button pendant <sup>3)</sup> controls valve and motor</li> <li>All options available.</li> </ul>		●	-	●	●	●	VE33	4
				●	-	●	●	●	VE33	8
				●	-	●	●	●	VE33	10
				-	●	●	●	●	VE43	10
				-	●	●	●	●	VE43	20
							40			

<sup>1)</sup> See Valve Section for hydraulic symbols and details.

<sup>2)</sup> For No Valve, with Electric Box, see ordering matrix on page 97.

<sup>3)</sup> Pendant includes 3 meters cord.

# ZE-Series, Electric Pumps

- High-efficiency pump design – higher oil flow and by-pass pressure
- High-strength, moulded electrical box protects electronics, power supplies and LCD readout and stands up to harsh industrial environments
- IP54 protection and isolation class
- Back-lit LCD provides self test, diagnostic and read-out capabilities never before offered on an industrial pump (included on pump with electric valves, optional on other models)
- Totally enclosed, fan-cooled industrial electric motors for extended life
- User adjustable relief valve built-in on manual and solenoid valves. Oil ports on valves are 3/8" NPTF
- Steel fan guard on all electric motors
- Full sight oil level glass
- 40 micron filter breather with splash guard
- Durable steel reservoirs.

## ZE Series







Reservoir Capacity:  
**4 - 40 litres**

Flow at Rated Pressure:  
**0,55 - 2,73 l/min**

Motor Size:  
**0,75 - 5,60 kW**

Maximum Operating Pressure:  
**700 bar**

ZE3-Series		ZE4-Series		ZE5-Series		ZE6-Series	
0,55 l/min at 700 bar Two-stage pump		0,82 l/min at 700 bar Two-stage pump		1,64 l/min at 700 bar Two-stage pump		2,73 l/min at 700 bar Two-stage pump	
Model Nr. <sup>4)</sup>	 (kg)	Model Nr. <sup>4)</sup>	 (kg)	Model Nr. <sup>4)</sup>	 (kg)	Model Nr. <sup>4)</sup>	 (kg)
400V / 3 phase		400V / 3 phase		400V / 3 phase		400V / 3 phase	
<b>ZE3004NW</b>	36	<b>ZE4004NW</b>	40	–	–	–	–
<b>ZE3010NW</b>	45	<b>ZE4010NW</b>	49	<b>ZE5010NW</b>	54	<b>ZE6010NW</b>	72
<b>ZE3020NW</b>	57	<b>ZE4020NW</b>	61	<b>ZE5020NW</b>	66	<b>ZE6020NW</b>	84
<b>ZE3040NW</b>	80	<b>ZE4040NW</b>	84	<b>ZE5040NW</b>	89	<b>ZE6040NW</b>	107
<b>ZE3204MW</b>	39	<b>ZE4204MW</b>	43	–	–	–	–
<b>ZE3308MW</b>	44	<b>ZE4308MW</b>	48	–	–	–	–
<b>ZE3610MW</b>	50	<b>ZE4610MW</b>	54	<b>ZE5610MW</b>	59	<b>ZE6610MW</b>	77
<b>ZE3420MW</b>	60	<b>ZE4420MW</b>	64	<b>ZE5420MW</b>	69	<b>ZE6420MW</b>	87
<b>ZE3840MW</b>	85	<b>ZE4840MW</b>	89	<b>ZE5840MW</b>	94	<b>ZE6840MW</b>	112
<b>ZE3204LW</b>	42	<b>ZE4204LW</b>	46	–	–	–	–
<b>ZE3208LW</b>	47	<b>ZE4208LW</b>	51	–	–	–	–
<b>ZE3310LW</b>	51	<b>ZE4310LW</b>	55	<b>ZE5310LW</b>	60	<b>ZE6310LW</b>	78
<b>ZE3610LW</b>	53	<b>ZE4610LW</b>	57	<b>ZE5610LW</b>	62	<b>ZE6610LW</b>	80
<b>ZE3420LW</b>	63	<b>ZE4420LW</b>	67	<b>ZE5420LW</b>	72	<b>ZE6420LW</b>	90
<b>ZE3840LW</b>	88	<b>ZE4840LW</b>	92	<b>ZE5840LW</b>	97	<b>ZE6840LW</b>	115
<b>ZE3104DW</b>	44	<b>ZE4104DW</b>	48	–	–	–	–
<b>ZE3108DW</b>	49	<b>ZE4108DW</b>	53	–	–	–	–
<b>ZE3110DW</b>	53	<b>ZE4110DW</b>	57	<b>ZE5110DW</b>	62	<b>ZE6110DW</b>	79
<b>ZE3120DW</b>	65	<b>ZE4120DW</b>	69	<b>ZE5120DW</b>	74	<b>ZE6120DW</b>	92
<b>ZE3140DW</b>	88	<b>ZE4140DW</b>	92	<b>ZE5140DW</b>	97	<b>ZE6140DW</b>	115
<b>ZE3304SW</b>	49	<b>ZE4304SW</b>	53	–	–	–	–
<b>ZE3308SW</b>	54	<b>ZE4308SW</b>	58	–	–	–	–
<b>ZE3310SW</b>	58	<b>ZE4310SW</b>	62	<b>ZE5310SW</b>	67	<b>ZE6310SW</b>	85
<b>ZE3410SW</b>	58	<b>ZE4410SW</b>	62	<b>ZE5410SW</b>	67	<b>ZE6410SW</b>	85
<b>ZE3420SW</b>	70	<b>ZE4420SW</b>	74	<b>ZE5420SW</b>	79	<b>ZE6420SW</b>	97
<b>ZE3440SW</b>	93	<b>ZE4440SW</b>	97	<b>ZE5440SW</b>	102	<b>ZE6440SW</b>	120

<sup>4)</sup> See custom ordering matrix on page 97 for other voltages.



### Adjustable Relief Valve

All VM and VE-Series have a user adjustable relief valve to allow the operator to easily set the optimum working pressure.



### Locking Valves

For applications requiring positive load holding, VM-Series valves (except VM32) are available with a pilot-operated check valve. This provides hydraulic locking of the load until the valve is shifted into the retract position. To order this feature on your ZE-series pump see the valve type in the order matrix.

Page: 97



### Single or Two-Stage

Choose single-stage pumps for applications that require constant flow regardless of pressure such as testing or clamping.

Two-stage pumps have an increased output flow at low pressure to allow fast movement towards the load, for reduced cycle times and increased productivity.





## Electric Box <sup>1)</sup>

- Back-lit LCD
- Pump usage information, hour and cycle counts
- Low-voltage warning and recording
- Self-test and diagnostic capabilities
- Pressure read-out <sup>2)</sup>
- Auto-mode pressure setting <sup>2)</sup>
- Information can be displayed in six languages <sup>3)</sup>

<sup>1)</sup> Included on pumps with solenoid valves. Can be factory installed on pumps with manual valve.

<sup>2)</sup> When used with optional pressure transducer.

<sup>3)</sup> English, French, German, Italian, Spanish and Portuguese.



## Level/Temperature Switch <sup>4)</sup>

- Shuts down pump before oil level reaches an unsafe level, avoiding damage due to cavitation
- Shuts down pump when unsafe oil temperature is reached
- Ideal if pump is used in remote area without visual access to oil level.

<sup>4)</sup> 24 V, requires Electric Box. Available for 10, 20 and 40 litres reservoirs.

Accessory Kit Modelnr.	Fixed Temperature Signal (°C)	Operating Temperature (°C)	Max. Pressure (bar)
ZLS-U4 *	80	5 - 110	10

\* Add suffix L for factory installation.



## Return Line Filter

- 25 micron nominal filter removes contaminants from return oil flow before allowing it back into tank
- Internal by-pass valve prevents damage if filter is dirty
- With maintenance indicator
- Replaceable filter element PF25.

Accessory Kit Modelnr.	Maximum Pressure (bar)	Maximum Oil Flow (l/min)	By-pass Setting (bar)
ZPF *	13,8	45,4	1,7

\* Add suffix F for factory installation.



## Roll Cage

- For easy portability and hoisting
- Protects pump and electric box
- Available for all reservoir sizes.



## Skid Bar

- Provides easy two-hand lift
- Provides greater pump stability on soft or uneven surfaces.



## Foot Switch <sup>5)</sup>

- Hands-free remote control on solenoid dump and 3-position valves
- With 3 meters cord.

<sup>5)</sup> 15 V, requires Electric Box.

Accessory Kit Nr.	Fits on reservoir	 (kg)
ZRC-04 *	4 and 8 litres <sup>5)</sup>	5,5
ZRC-04H *	4 and 8 litres <sup>6)</sup>	6,5
ZRB-10 *	10 litres	6,0
ZRB-20 *	20 litres	6,0
ZRB-40 *	40 litres	6,0

\* Add suffix R for factory installation.

<sup>5)</sup> For pump without heat exchanger

<sup>6)</sup> For pump with heat exchanger.

Accessory Kit Nr.	Fits on reservoir	 (kg)
SBZ-4 *	4 and 8 litres <sup>5)</sup>	2,2
SBZ-4L *	4 and 8 litres <sup>6)</sup>	3,2

\* Add suffix K for factory installation.

<sup>5)</sup> For pump without heat exchanger

<sup>6)</sup> For pump with heat exchanger.

Accessory Kit Nr.	Can be used on ZE-Series pumps with
ZCF-2 *	Solenoid VE-Series valves

\* Add suffix U for factory installation.

# ZE-Series, Options & Accessories



## Pressure Transducer <sup>1)</sup>

- Displays pressure on LCD in bar, MPa or psi
- More accurate than analog gauge
- Calibration can be fine-tuned for certification
- Easy-viewing variable rate display
- “Set pressure” feature turns off motor at user defined pressure <sup>2)</sup>.

<sup>1)</sup> 24 V, requires Electric Box.

<sup>2)</sup> Or shifts valve to neutral position on pump models with VE33 and VE43 solenoid valves.

Accessory Kit Modelnr.	Adjustable Pressure Range (bar)	Switch-point repeatability	Dead-band (bar)
ZPT-U4 *	3,5 - 700	± 0,5%	3,5

\* Add suffix **T** for factory installation.



## Pressure Switch <sup>3)</sup>

- Controls pump, monitors system
- Adjustable pressure 35-700 bar
- Includes glycerine filled 1000 bar pressure gauge G2536L
- Accuracy ± 1,5% of full scale.

<sup>3)</sup> 24 V, requires Electric Box. Not available in combination with pressure transducer.

Accessory Kit Modelnr.	Switch-point repeatability	Deadband (bar)	Oil Ports (NPTF)
ZPS-E3 *	± 2%	8 - 38	3/8"

\* Add suffix **P** for factory installation.



## Options

Accessory Kits can be installed by customer. See chart below for options on Standard Electric (without electric box) or LCD Electric (with electric box). Refer to page 97 for ordering matrix.

ZE-Series Options	Factory Installed		Accessory Kits	
	Std. Electr.	LCD Electr.	Std. Electr.	LCD Electr.
Return Line Filter	F	F	ZPF	ZPF
Skid Bar <sup>1)</sup>	K	K	SBZ	SBZ
Roll Cage	R	R	ZRB	ZRB
Single-stage	S	S	-	-
Heat Exchanger	-	H	-	ZHE
Pressure Gauge <sup>2)</sup>	G	G	-	-
Pressure Switch <sup>3)</sup>	-	P	-	ZPS-E3
Pressure Transducer <sup>4)</sup>	-	T	-	ZPT-U4
Level/Temp Switch <sup>5)</sup>	-	L	-	ZLS-U4
Foot Switch <sup>6)</sup>	-	U	-	ZCF-2

<sup>1)</sup> Available for 4 and 8 litres reservoirs.

<sup>2)</sup> Not available on pumps with pressure transducer.

<sup>3)</sup> Includes 1000 bar gauge. Only available on manual valves without locking feature.

<sup>4)</sup> Electric box can accept either pressure switch or pressure transducer, but not both.

<sup>5)</sup> Available for 10, 20 and 40 litres reservoirs.

<sup>6)</sup> For control of solenoid dump and 3-position valves.



## Pendants <sup>4)</sup>

- For pump types with valve operation “W” (No Valve, with Electric Box, without pendant).

<sup>4)</sup> When ordering Enerpac VE-Series solenoid valve the pendant must be ordered separately. Pendant connection to be plugged into electric box.

Pendant Model Nr.	To be used with solenoid valve:
ZCP-1	VE32D
ZCP-3	VE32, VE33, VE43



## Heat Exchanger <sup>5)</sup>

- Removes heat from by-pass oil to provide cooler operation
- Stabilizes oil viscosity, increasing oil life and reduces wear of pump and other hydraulic components.

Accessory Kit Nr.	Fits on reservoir	(kg)
ZHE-E04 *	4 and 8 litres	4,1
ZHE-E10 *	10, 20 and 40 litres	4,1

<sup>5)</sup> 24 VDC, requires electric box.

\* Add suffix **H** for factory installation.



## ZPT-U4 Pressure Transducer

More durable against mechanical and hydraulic shock than analog gauges.

- Digital pressure read-out provides accuracy of 0,5% of full scale.
- Easy-viewing variable rate display automatically varies increments between 3, 14, 35 and 145 bar as rate of pressure change increases.
- “Set pressure” feature turns off motor at user defined pressure (or shifts valve to neutral on VE33 and VE43 valves).



## ZHE-Series Heat Exchangers

Heat exchanger stabilizes oil temperature at 54 °C at 21 °C ambient temperature. Thermal transfer at 1,9 l/min and 21 °C ambient temperature: 900 Btu/hour [950 kJ].

Do not exceed max. oil flow of 26,5 l/min and max. pressure of 20,7 bar. Not suitable for water-glycol or high water based fluids.

# ZE-Series, Specifications & Dimensions

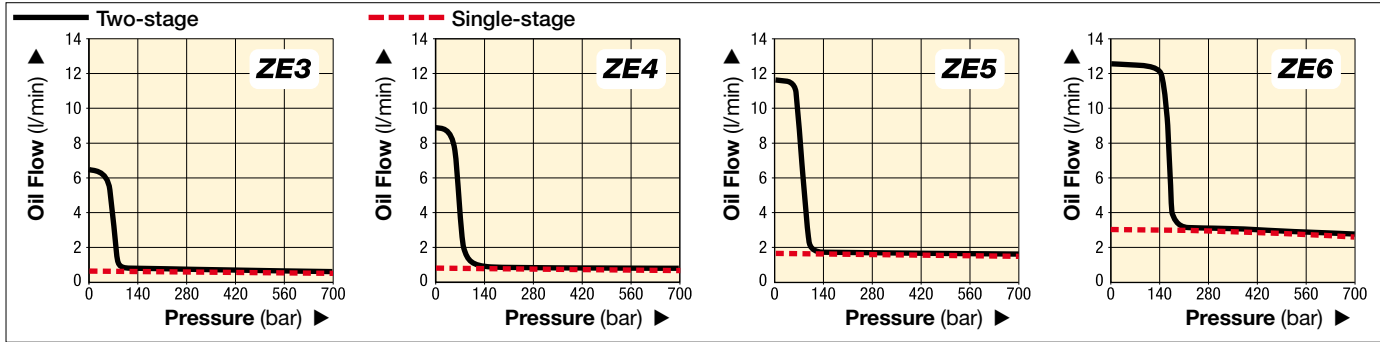

## ▼ ZE-SERIES PERFORMANCE CHART

Pump Series	Output Flow Rate at 50 Hz * (l/min)				Pump Unit	Available Reservoir Sizes (useable oil) (litres)	Motor Size (kW)	Relief Valve Adjustment Range (bar)	Sound Level (dBA)
	low pressure at 7 bar	low pressure at 50 bar	high pressure at 350 bar	high pressure at 700 bar					
ZE3	0,59	0,59	0,57	<b>0,55</b>	Single-stage	4-8-10-20-40	0,75	70-700	75
	6,15	5,26	0,57	<b>0,55</b>	Two-stage				
ZE4	0,87	0,87	0,84	<b>0,82</b>	Single-stage	4-8-10-20-40	1,12	70-700	75
	8,88	8,20	0,84	<b>0,82</b>	Two-stage				
ZE5	1,75	1,72	1,68	<b>1,64</b>	Single-stage	10-20-40	2,24	70-700	75
	11,61	11,27	1,68	<b>1,64</b>	Two-stage				
ZE6	3,00	2,94	2,86	<b>2,73</b>	Single-stage	10-20-40	5,60	70-700	80
	12,29	12,15	2,86	<b>2,73</b>	Two-stage				

\* Oil flow will be approximately 6/5 of these values at 60 Hz.



### Single or Two-Stage

Choose single-stage pumps for applications that require constant flow regardless of pressure such as testing or clamping. Two-stage pumps have an increased output flow at low pressure to allow fast movement towards the load, for reduced cycle times and increased productivity.

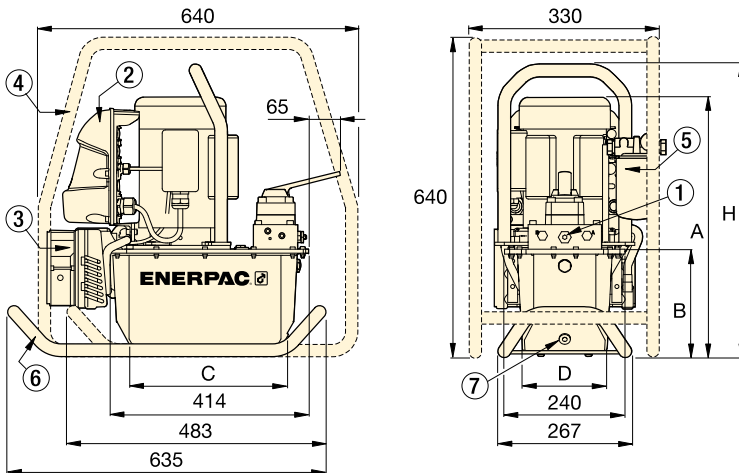

## ZE-Series Pumps with 4 - 8 litres reservoir

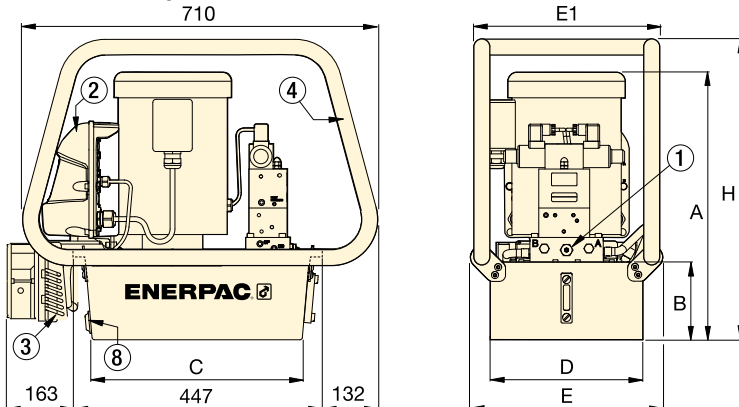

## ZE-Series Pumps with 10 - 20 - 40 litres reservoir

- ① User adjustable relief valve on all manual and solenoid valves.  
3/8" NPTF on A and B ports;  
1/4" NPTF on auxiliary ports.
- ② Electric Box
- ③ Heat Exchanger
- ④ Roll Cage
- ⑤ Return Line Filter
- ⑥ Skid Bar
- ⑦ Magnetic Oil Drain
- ⑧ Oil Drain / Oil Level/Temperature Switch

Reservoir Size (useable oil in litres)	ZE-Series Pump Dimensions (mm)						
	A	B	C	D	E	E1	H
4	446	302	279	152	-	-	512
8	446	302	279	205	-	-	512
10	533	380	419	305	384	340	600
20	558	380	419	422	501	490	625
40	648	380	399	505	576	572	715



# ZE-Series, Pump Ordering Matrix

▼ This is how ZE-Series pump model numbers are built up:

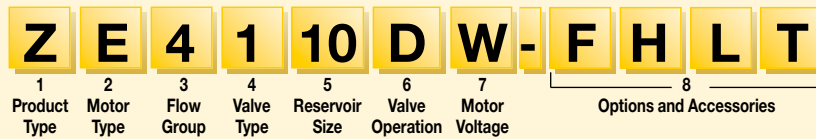

## 1 Product Type

**Z** = Pump Class

## 2 Prime Mover

**E** = Induction electric motor

## 3 Flow Group

- 3** = 0,55 l/min @ 700 bar (0,75 kW)
- 4** = 0,82 l/min @ 700 bar (1,12 kW)
- 5<sup>1)</sup>** = 1,64 l/min @ 700 bar (2,24 kW)
- 6<sup>1)</sup>** = 2,73 l/min @ 700 bar (5,60 kW)

## 4 Valve Type

- 0** = No valve, with cover plate
- 1** = 3/2 Dump valve **VE32D**
- 2** = 3/2 manual **VM32**
- 3** = 3/3 manual **VM33** or electric **VE33**
- 4** = 4/3 manual **VM43** or electric **VE43**
- 6** = 3/3 manual locking valve **VM33L** with pilot operated check.
- 8** = 4/3 manual locking valve **VM43L** with pilot operated check.

## 5 Reservoir Size, useable oil

- 04<sup>2)</sup>** = 4 litres
- 08<sup>2)</sup>** = 8 litres
- 10** = 10 litres
- 20** = 20 litres
- 40** = 40 litres

## 8 Options and Accessories

- F** = Return Line Filter
- G<sup>6)</sup>** = 1000 bar gauge
- H<sup>7)</sup>** = Heat exchanger
- K** = Skid Bar (only on 4-8 litres)
- L<sup>7)</sup>** = Oil Level/Temperature Switch <sup>8)</sup>
- N** = No reservoir handles (includes lifting eyes)
- P<sup>7)</sup>** = Pressure Switch (only available on manual valves without locking feature)
- R** = Roll Cage
- S** = Single-stage pump unit
- T<sup>7)</sup>** = Pressure transducer <sup>9)</sup>
- U<sup>7)</sup>** = Foot Switch

<sup>1)</sup> ZE5 and ZE6-Series only available with 3-phase electric motors.

<sup>2)</sup> 4 and 8 litres only available on ZE3 and ZE4-Series.

<sup>3)</sup> 1-phase motors only available on ZE3 and ZE4-Series

<sup>4)</sup> 208-240V, 1 ph with European plug EMC directive compliant.

<sup>5)</sup> Models with 3-ph motors without Electric Box shipped without cord, motor starter or overload protection.

<sup>6)</sup> Not available on pumps with pressure transducer (T).

<sup>7)</sup> Requires Electric Box.

<sup>8)</sup> Not available on 4 and 8 litres reservoir.

<sup>9)</sup> Provides digital pressure read-out on LCD-display of electric box.

<sup>10)</sup> When using solenoid valve on valve type "W" order optional pendant.

All Z-Class electric pumps comply with TÜV and CE requirements.



## ZE Series



Reservoir Capacity:

**4 - 40 litres**

Flow at Rated Pressure:

**0,55 - 2,73 l/min**

Motor Size:

**0,75 - 5,60 kW**

Maximum Operating Pressure:

**700 bar**



### How to Order Single-Stage Pumps

To specify a single-stage pump, place the letter "S" at the end of the model number. For example:

#### ZE4210ME-S

ZE4-Series pump, oil flow 0,82 l/min at 700 bar, VM32 manual valve, 10 litres reservoir, without electrical box, without pendant, 240 Volt 1-phase electric motor and single-stage pump unit.

#### ZE3120DW-S

ZE3-Series pump, oil flow 0,55 l/min at 700 bar, VE32D solenoid dump valve, 20 litres reservoir, with electrical box (LCD), without pendant, 400 Volt 3-phase electric motor and single-stage pump unit.



### Pendants

When ordering Enerpac VE-Series solenoid valve for use on "W" type valve operation (No Valve, with

Electric Box (LCD), without pendant) the pendant must be ordered separately. Pendant connection to be plugged into electric box.



▼ Shown: PPE-9483-4



## The Axial Piston Pump with four independant outlets

- Single-speed operation with two and four independent split-flow outlets
- Two-speed operation with high-flow outlet
- Oil delivery of each outlet remains equal regardless of pressure
- 60 litres usable oil capacity allows operation of a wide range of cylinders
- Powerful 4 and 9,5 kW motor, available in three voltage options.

▼ To lift a rigid construction, four double-acting RR-2006 cylinders are powered by a 4-split flow electric PPE-9483-4 pump.



### Hoses

Enerpac offers a complete line of high quality hydraulic hoses. To ensure the integrity of your system, specify only genuine Enerpac hydraulic hoses.

Page: 120



### Gauges

Minimize the risk of overloading and ensure long, dependable service from your equipment. Refer to the System Components section for a full range of gauges.

Page: 128



### Locking Valves

Pumps with VM33 or VM43 manual valves may be ordered with locking valves. This locking feature provides

a hydraulic lock for the cylinder using pilot-operated check valves. To order this option, just place an "L" suffix at the end of the model number. For more information, contact your local Enerpac office.

Page: 114

Pump Type	Motor Size (kW)	Usable Oil Capacity (litres)	Pump Series*	Pressure Rating (bar)		Output Flow Rate (l/min)	
				1st stage	2nd stage	1st stage	2nd stage
Two-speed	4,0	60	PPN-8000	190	700	14,5	1 x 4,2
	9,5	60	PPN-9000	300	700	14,5	1 x 8,0
Single-speed	9,5	60	PPN-9000-2	–	700	–	2 x 5,0
	9,5	60	PPN-9000-4	–	700	–	4 x 2,5

\* The "N" in the model number stands for No Valve. All pump models can be ordered with Manual or Solenoid Valves. See selection chart on next page.

# PP-8000 and 9000-Series, Electric Pumps

▼ This is how 8000 and 9000-Series Pump model numbers are built up:



### 1 Product Type

PP = Power Pump

### 2 Valve Control

N = No Valve  
M = Manual  
E = Solenoid (Electrical)

### 3 Pump Series

8 = 8000-Series, 4 kW  
9 = 9000-Series, 9,5 kW

### 4 Valve Type

0 = No Valve  
3 = 3-way, 3-position, manual valve (VM33) or solenoid valve (VE33)  
4 = 4-way, 3-position, manual (VM43) or solenoid valve (VE43)

### 5 Reservoir Capacity

8 = 80 litres (usable 60 ltr)

### 6 Motor Voltage\*

3 = 400 V, 3 ph, 50 Hz  
5 = 230 V, 3 ph, 50 Hz  
6 = 440 V, 3 ph, 50 Hz

\* In the selection chart below only 400V models (suffix 3) are shown. To order 230V or 440V models, change this suffix to 5 or 6.

### 7 Split-Flow Outlets

*9000-Series only*  
2 = 2 equal flow outlets of 5,0 l/min. at 700 bar  
4 = 4 equal flow outlets of 2,5 l/min. at 700 bar

## PP Series



Reservoir Capacity:

**80 litres**

Flow at Rated Pressure:

**4 x 2,5 to 8,0 l/min**

Motor Size:

**4,0 - 9,5 kW**

Maximum Operating Pressure:

**700 bar**



### Speed Chart

To determine how a specific pump will operate your cylinder, see the Pump-Cylinder Speed Chart in the 'Yellow Pages'.

Page: 249

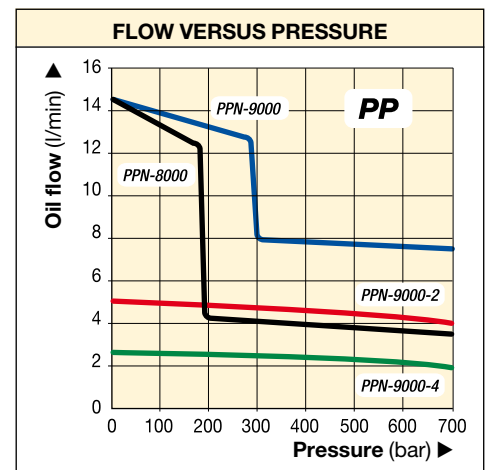
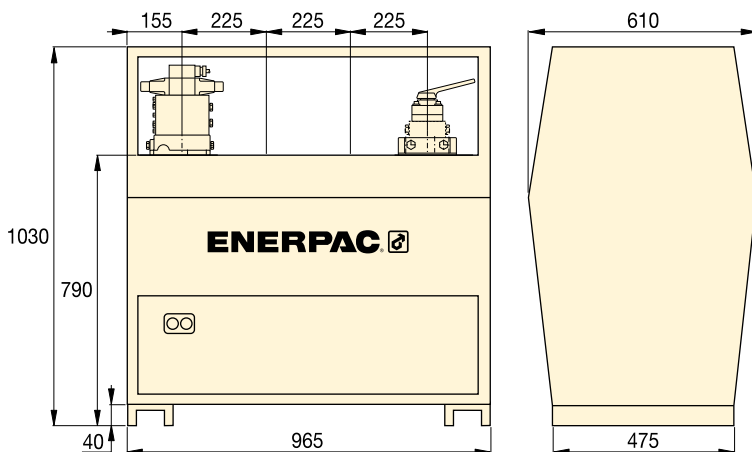

Used with Cylinder*	Valve Control	Valve Function			Valve Model Number	8000-Series High-flow outlet		9000-Series High-flow outlet		9000-Series 2 Split-flow outlets		9000-Series 4 Split-flow outlets	
		▲	■	▼		Model Number	(kg)	Model Number	(kg)	Model Number	(kg)	Model Number	(kg)
-	-	-	-	-	-	PPN-8083	274	PPN-9083	303	PPN-9083-2	304	PPN-9083-4	328
●	Manual	●	●	●	VM33	PPM-8383	275	PPM-9383	316	PPM-9383-2	319	PPM-9383-4	333
	● Manual	●	●	●	VM43	PPM-8483	275	PPM-9483	316	PPM-9483-2	319	PPM-9483-4	333
	● Solenoid	●	●	●	VE43	PPE-8483	286	PPE-9483	330	PPE-9483-2	340	PPE-9483-4	372

\* = Single-Acting = Double-Acting

▼ Shown: **XA11G**



- Ergonomic design for less operator fatigue
- Variable oil flow & fine metering for precise control
- Higher oil flow for increased productivity
- Closed hydraulic system prevents contamination and allows pump usage in any position
- Pedal lock function for retract position
- Ground screw for improved ATEX explosion safety
- External adjustable pressure setting valve.

▼ Easy operated by foot. No need to fully lift up foot – rest bodyweight on heel, resulting in a handsfree and stable working position.



## XVARI<sup>®</sup> TECHNOLOGY

### Productivity & Ergonomics



#### Optional Pressure Gauge

Integrated gauge with calibrated scale reading in bar, psi and MPa for actual pressure reading.



#### 4/3 Control Valve

For powering double-acting hydraulic cylinders and tools.



#### 2 Litres Reservoir

Double oil capacity for powering larger hydraulic cylinders and tools.



#### Pedal Safety Guard

Customer installed frame protects both pedals against accidental activation.

Model Number <sup>1)</sup>

**XPG1**



#### "Joy-stick" Lever Kit

Customer installed set of handles for manual operation of both pedals.

Model Number <sup>1)</sup>

**XLK1**



#### Swivel Connector

Customer installed swivel connector for optimal orientation of the hydraulic hose.

Model Number <sup>1)</sup>

**XSC1**

<sup>1)</sup> Accessories must be ordered separately.

# XVARI® Technology, Air Driven Hydraulic Foot Pumps



## XVARI® Technology Production Application

XA11 pump is used with a 13 tons hollow cylinder to compress and position diesel engine valve springs. The operator benefits from the fine metering capacities of the XVARI® Technology to apply the mandatory precise stroke and force.

[www.xvari.com](http://www.xvari.com)

## XA Series



Reservoir Capacity:  
**1,0 - 2,0 litres**

Flow at Rated Pressure:  
**0,25 l/min**

Air Consumption:  
**283 - 991 l/min**

Maximum Operating Pressure:  
**700 bar**

### ▼ XA-SERIES PERFORMANCE CHART

Maximum Pressure (bar)	Output Flow Rate (l/min)		Pump Series	Valve Function	Dynamic Air Pressure (bar)
	No load	Load			
700	2,0	0,25	<b>XA1</b>	Advance/Hold/Retract	2,1 - 8,6

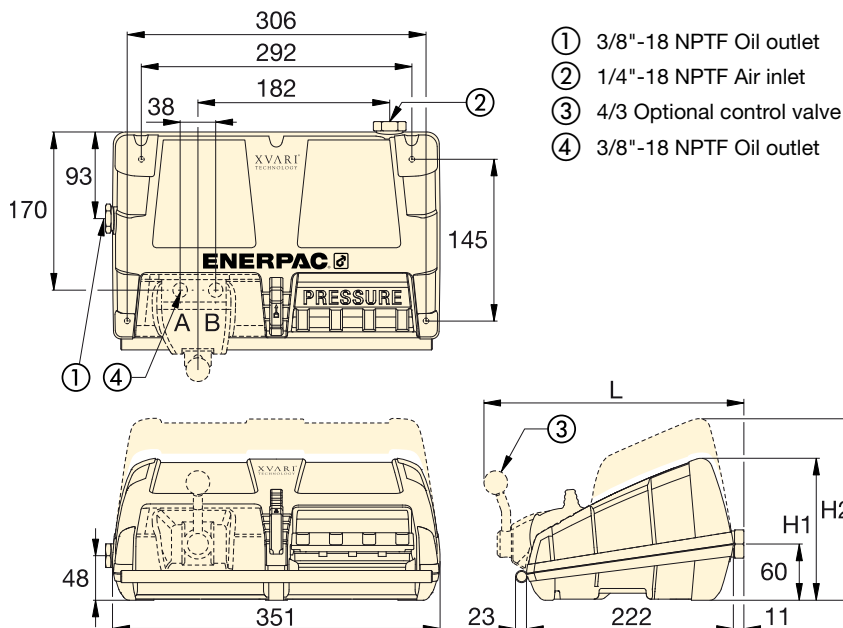

### OIL FLOW VERSUS PRESSURE

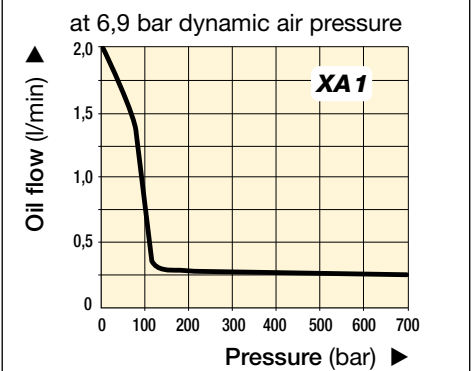

### Regulator-Filter-Lubricator

Recommended for use with all XA-Series Air pumps. Provides clean, lubricated air and allows for air pressure adjustment.

Model Number **RFL102**

### ▼ SELECTION CHART

For use with cylinder or tool	Usable Oil Capacity (litres)	Model Number <sup>1)</sup>	Pressure Gauge	3-way 3-pos. Valve	4-way 3-pos. Valve	Dimensions (mm)			 (kg)
						H1	H2	L	
Single-acting	1,0	<b>XA 11</b> <sup>2)</sup>	–	•	–	152	–	–	8,6
	2,0	<b>XA 12</b> <sup>2)</sup>	–	•	–	–	170	–	10,2
Single-acting	1,0	<b>XA 11G</b>	•	•	–	152	–	–	8,8
	2,0	<b>XA 12G</b>	•	•	–	–	170	–	10,4
Double-acting	1,0	<b>XA 11V</b>	–	–	•	152	–	279	10,1
	2,0	<b>XA 12V</b>	–	–	•	–	170	279	11,7
Double-acting	1,0	<b>XA 11VG</b>	•	–	•	152	–	279	10,3
	2,0	<b>XA 12VG</b>	•	–	•	–	170	279	11,9

<sup>1)</sup> High-Flow coupler CR-400 and accessories must be ordered separately.

<sup>2)</sup> Available as cylinder-pump set, see page 62.



# PA-Series, Turbo II Air Hydraulic Pumps

▼ Shown from top to bottom: PAMG-1402N, PARG-1102N, PATG-1102N, PATG-1105N



- External adjustable pressure relief valve (behind sight glass)
- Return-to-tank port for use in remote valve applications
- Internal pressure relief valve provides overload protection
- Quieter operation – reduced noise level to 76 dBA
- Operating air pressure: 2,8 - 8,8 bar, enables pump to start at extremely low pressure
- High efficiency cast aluminium air motor
- Reinforced heavy-duty lightweight reservoir for applications in tough environments
- Air pendant for remote control operation .

## Compact Air Over Hydraulic



### Regulator-Filter-Lubricator

Recommended for use with all Turbo air pumps. Provides clean, lubricated air and allows for air pressure

adjustment. Steel bowl guards are standard.

Model Number

**RFL102**



### Large Reservoir Models

The Turbo II Air Pump is also available with an enlarged reservoir: **PATG-1105N**, **PAMG-1405N** and **PARG-1105N**.



### Hoses

Enerpac offers a complete line of high quality hydraulic hoses. To ensure the integrity of your system, specify only genuine Enerpac hydraulic hoses.

Page: **120**

▼ Easily operated by hand or by foot.



Used with Cylinder	Usable Oil Capacity (cm <sup>3</sup> )	Model Number
Single-Acting	2081	<b>PATG-1102N</b>
	3770	<b>PATG-1105N</b>
Single-Acting	2081	<b>PARG-1102N</b>
	3770	<b>PARG-1105N</b>
Double-Acting	2081	<b>PAMG-1402N</b>
	3770	<b>PAMG-1405N</b>

# PA-Series, Turbo II Air Hydraulic Pumps



PATG-models use a foot or hand operated treadle to control air and valve functions.

PAMG-models use a treadle with a locking feature to control air, and a 4-way manual valve to control hydraulics.

PARG-models use air pendant for remote control.

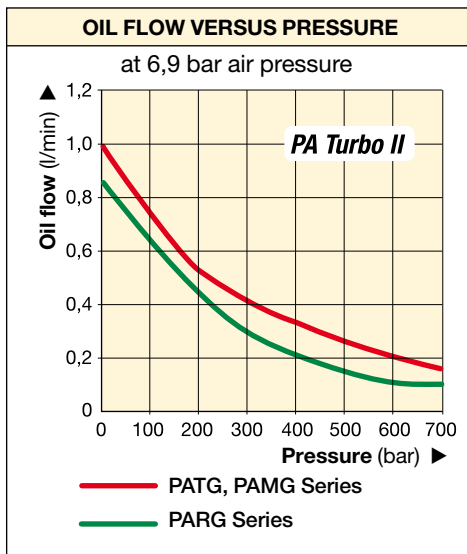

**PATG  
PAMG  
PARG  
Series**



Reservoir Capacity:  
**2,5 - 5,0 litres**

Flow at Rated Pressure:  
**0,08 - 0,16 l/min**

Air Consumption:  
**227 - 340 l/min**

Maximum Operating Pressure:  
**700 bar**

Maximum Pressure (bar)	Output Flow Rate (l/min)		Pump Series	Valve Function	Air Pressure Range (bar)	Air Consumption (l/min) at 5,2 bar air	Sound Level (dBA)
	No Load	No Load					
700	1,00	0,16	PATG	A / H / R *	2,8 - 8,8	340	76
700	0,76	0,08	PARG	A / H / R *	2,8 - 10,3	227	76
700	1,00	0,16	PAMG	A / H / R *	2,8 - 8,8	340	76

\* Valve function: Advance / Hold / Retract.



## Speed Chart

To determine how a specific pump will operate your cylinder, see the Pump-Cylinder Speed Chart in the 'Yellow Pages'.

Page: 249

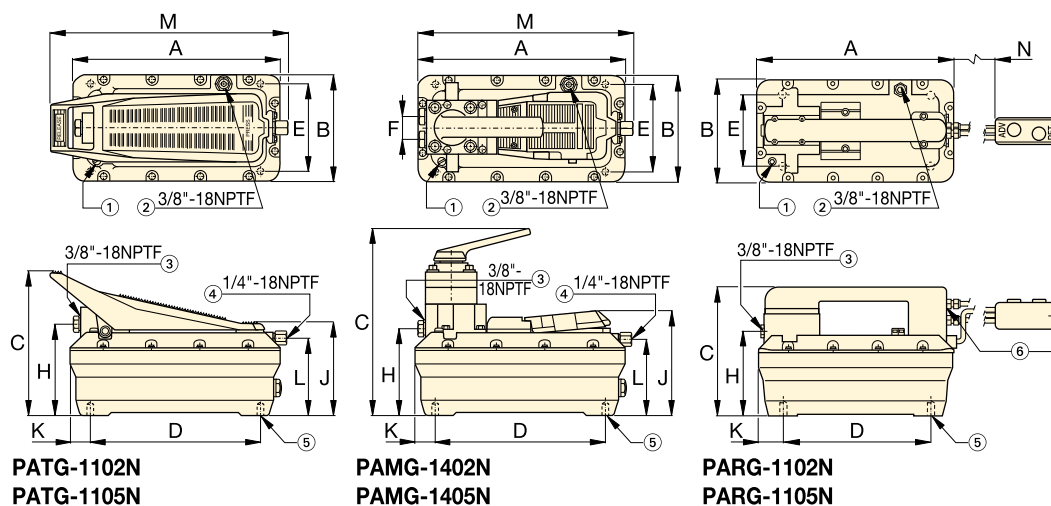

- ① Filtered 'Permanent' Tank Vent
- ② Return-to-Tank/Auxiliary Vent/Fill Tank Port
- ③ Hydraulic Output
- ④ Swivel Air Input with Filter
- ⑤ 4 Mounting Holes for #10 thread forming screw. Maximum depth into reservoir = 19 mm
- ⑥ Air Input with Filter on PARG models 1/4"-18NPTF

Valve Operation	Turbo II Dimensions (mm)													Model Number
	A	B	C	D	E	F	H	J	K	L	M	N	(kg)	
Treadle 3/3	313	165	211	230	102	-	129	146	42	113	347	-	8,2	PATG-1102N
	396	201	209	230	102	-	131	146	86	112	437	-	9,9	PATG-1105N
Air Pendant 3/3	313	165	200	230	102	-	129	-	42	-	-	4500	10,0	PARG-1102N
	396	201	209	230	102	-	131	-	86	-	-	4500	11,7	PARG-1105N
Manual 4/3	313	165	267	230	102	36	130	152	42	113	315	-	11,0	PAMG-1402N
	396	201	267	230	102	36	132	152	86	112	405	-	12,7	PAMG-1405N

# PA-Series, Air Hydraulic Foot Pumps

▼ Shown from top to bottom: PA-1150, PA-133



## PA Series

Reservoir Capacity:  
**0,6 - 1,3 litres**

Flow at Rated Pressure:  
**0,13 l/min**

Air Consumption:  
**255 l/min**

Maximum Operating Pressure:  
**700 bar**



### Reservoir Conversion Kit

Double the reservoir capacity of your existing PA-133 with this easy to install conversion kit.

Model Number

**PC-66**

- Rugged construction – built for long life and easy service
- Swivel coupling simplifies hydraulic connection and pump operation
- Three-position treadle provides cylinder advance, hold or retract operation
- Operates in all positions for increased versatility in use and mounting (except PA-1150)
- Base mounting slots provided on PA-133.

### OIL FLOW VERSUS PRESSURE

at 6,9 bar air pressure

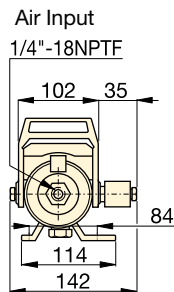
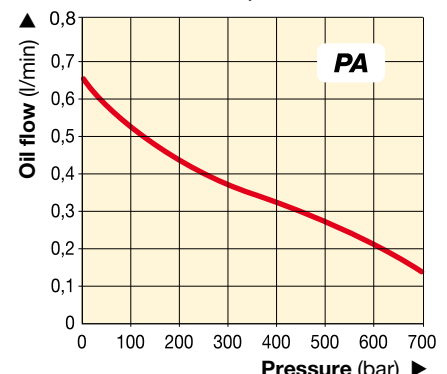

PA-133

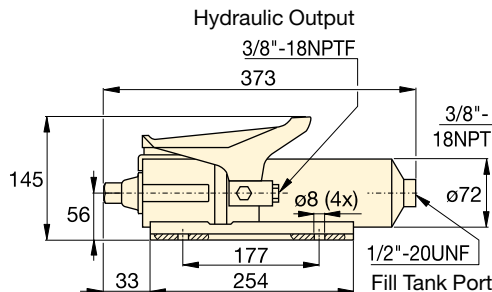

PA-1150

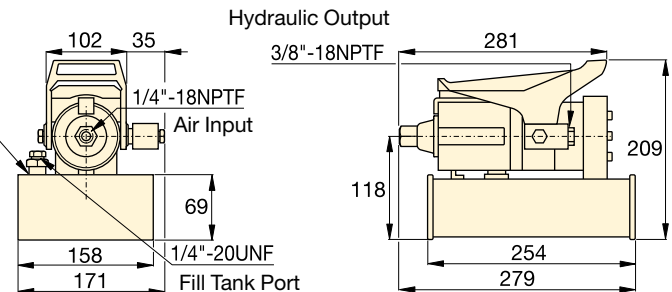

Used with Cylinder	Usable Oil Capacity (cm <sup>3</sup> )	Model Number	Pressure Rating (bar)	Output Flow Rate (l/min)		Valve Function	Air Pressure Range* (bar)	Air Consumption (l/min)	Sound Level (dBA)	 (kg)
				No load	Load					
Single-Acting	589	PA-133	700	0,65	0,13	Advance/Hold/Retract	4,1 - 8,3	255	85	5,4
	1311	PA-1150	700	0,65	0,13	Advance/Hold/Retract	4,1 - 8,3	255	85	8,2

\* Recommended Regulator-Filter-Lubricator: RFL-102.

# PAM-Series, Air Hydraulic Pumps

▼ Shown: PAM-1041



- Twin air motor configuration delivers high-flow performance in first stage, up to 14 bar, for rapid cylinder advance
- 4 and 8 litres reservoirs for use with a wide range of cylinders
- Integral shroud protects air motors and provides easy portability.

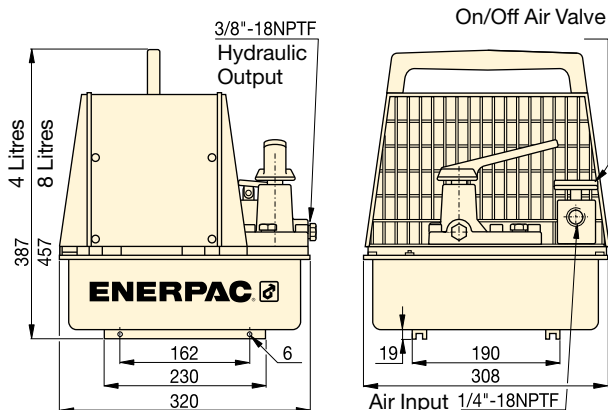

PAM-Series

## PAM Series

Reservoir Capacity:  
**4,0 - 8,0 litres**

Flow at Rated Pressure:  
**0,15 l/min**

Air Consumption:  
**510 l/min**

Maximum Operating Pressure:  
**700 bar**



### Locking Valves

Pumps with 4/3 manual valves are available with 4/3 manual locking valves instead. Add suffix "L" to pump model number.

Page: 114



### Remote Air Valve

For remote operation of PAM-Series air pumps. Permits either hand or foot operation.

Model Number

VA-2

### OIL FLOW VERSUS PRESSURE

at 6,9 bar air pressure

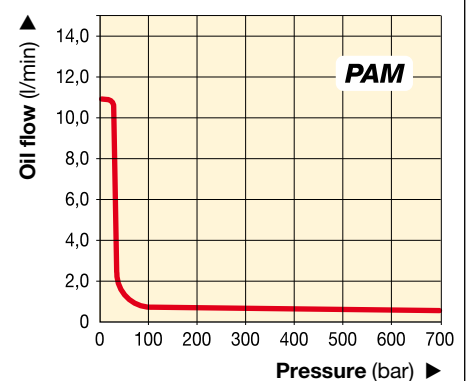

Used with Cylinder	Usable Oil Cap. (litres)	Model Number with Shroud	Pressure Rating (bar)	Output Flow Rate (l/min)		Valve Function	Valve Type	Air Pressure Range* (bar)	Air Consumption (l/min)	Sound Level (dBA)	Weight (kg)
				1 <sup>st</sup> stage	2 <sup>nd</sup> stage						
Single-Acting	2,6	PAM-1021	700	10,65	0,15	Adv./Hold/Retr.	3/2	4,1 - 8,3	510	87	22,7
	7,6	PAM-1022	700	10,65	0,15	Adv./Hold/Retr.	3/2	4,1 - 8,3	510	87	27,2
Double-Acting	2,6	PAM-1041	700	10,65	0,15	Adv./Hold/Retr.	4/3	4,1 - 8,3	510	87	22,7
	7,6	PAM-1042	700	10,65	0,15	Adv./Hold/Retr.	4/3	4,1 - 8,3	510	87	27,2

\* Recommended Regulator-Filter-Lubricator: RFL-102.



# ZA4-Series, Modular Air Hydraulic Pumps

▼ Shown: ZA4208MX, ZA4420MX



**Z** Tough  
Dependable  
Innovative  
**CLASS**



### ATEX 95 Certified

The Enerpac ZA4-series air pumps are tested and certified according to the **Equipment Directive 94 / 9 / EC "ATEX Directive"** for equipment and protective systems intended for use in potentially explosive atmospheres.

**Ex** II 2 GD ck T4

Page: **239**

- ATEX 95 certified for use in potentially explosive atmospheres
- Features Z-Class high efficiency pump design, higher oil flow and bypass pressure
- Two-speed operation reduces cycle time for improved productivity
- User adjustable relief valve built-in on manual valves. Oil ports on valves are 3/8" NPTF
- Optional heat exchanger warms exhaust air to prevent freezing and cools the oil
- Full sight oil level glass on 10, 20 and 40 litres reservoirs, oil level indicators on 4 and 8 litres reservoirs.



### Speed Chart

To determine how a specific pump will operate your cylinder, see the Pump-Cylinder Speed Chart in the 'Yellow Pages'.

Page: **249**



### Hoses

Enerpac offers a complete line of high quality hydraulic hoses. To ensure the integrity of your system, specify only genuine Enerpac hydraulic hoses.

Page: **120**

Used with Cylinder	Usable Oil Capacity (litres)	Manual Valve <sup>1)</sup> Model Number	Valve Function	Model Number	Output Flow Rate <sup>3)</sup> (l/min)				Relief Valve Adjustment Range (bar)	Maximum Air Consumption <sup>4)</sup> (l/min)
					at 7 bar	at 50 bar	at 350 bar	at 700 bar		
–	4,0	– <sup>2)</sup>	–	<b>ZA4004NX</b> <sup>2)</sup>	14,0	11,0	1,8	<b>1,3</b>	–	2840
Single-acting	4,0	VM32	Advance/Retract	<b>ZA4204MX</b>	14,0	11,0	1,8	<b>1,3</b>	70 - 700	2840
	8,0	VM33	Advance/Hold/Retract	<b>ZA4308MX</b>	14,0	11,0	1,8	<b>1,3</b>	70 - 700	2840
	10,0	VM33L	Advance/Hold/Retract	<b>ZA4610MX</b>	14,0	11,0	1,8	<b>1,3</b>	70 - 700	2840
Double-acting	4,0	VM43	Advance/Hold/Retract	<b>ZA4404MX</b>	14,0	11,0	1,8	<b>1,3</b>	70 - 700	2840
	8,0	VM43	Advance/Hold/Retract	<b>ZA4408MX</b>	14,0	11,0	1,8	<b>1,3</b>	70 - 700	2840
	10,0	VM43L	Advance/Hold/Retract	<b>ZA4810MX</b>	14,0	11,0	1,8	<b>1,3</b>	70 - 700	2840
	20,0	VM43	Advance/Hold/Retract	<b>ZA4420MX</b>	14,0	11,0	1,8	<b>1,3</b>	70 - 700	2840
	40,0	VM43	Advance/Hold/Retract	<b>ZA4440MX</b>	14,0	11,0	1,8	<b>1,3</b>	70 - 700	2840

<sup>1)</sup> See pages 114-116 for hydraulic symbols of these valves.

<sup>2)</sup> For remote valve mounting order **BSS1090** high pressure connecting plate.

<sup>3)</sup> Actual oil flow will vary with air supply.

<sup>4)</sup> Dynamic air pressure range: 4 - 7 bar.

# Modulair Air Hydraulic Pumps

▼ This is how a ZA4-Series pump model number is built up:



### 1 Product Type

**Z** = Pump Class

### 2 Prime Mover

**A** = Air motor

### 3 Flow Group

**4** = 1,3 l/min @ 700 bar

### 4 Valve Type

- 0** = No valve, with cover plate
- 2** = 3/2 manual valve VM32
- 3** = 3/3 manual valve VM33
- 4** = 4/3 manual valve VM43
- 6** = 3/3 manual locking valve VM33L with pilot operated check
- 7** = 3/2 manual valve VM22
- 8** = 4/3 manual locking valve VM43L with pilot operated check.

### 5 Reservoir Size, useable oil

- 04** = 4 litres
- 08** = 8 litres
- 10** = 10 litres
- 20** = 20 litres
- 40** = 40 litres

### 6 Valve Operation

- M** = Manual valve
- N** = No valve

### 7 Motor Voltage

- X** = Not applicable

### 8 Options

- F** = Return Line Filter
- G** = 1000 bar gauge
- H** = Heat exchanger\*
- K** = Skid Bar\*
- N** = No reservoir handles (includes lifting eyes on 10, 20 and 40 litres)
- R** = Roll Cage

### Ordering Example

Model Number: **ZA4208MX-FHK**  
 ZA4208MX-FHK is an air operated pump with a 3-way, 2-position manual valve, 8 litres reservoir, filter, heat exchanger and skid bar.

\* On 4 and 8 litres reservoir only.

## ZA4 Series



Reservoir Capacity:

**4 - 40 litres**

Flow at Rated Pressure:

**1,3 l/min**

Air Consumption:

**2840 l/min**

Maximum Operating Pressure:

**700 bar**

- ① User adjustable relief valve on all manual valves. 3/8" NPTF on A and B ports; 1/4" NPTF on auxiliary ports.
- ② Air inlet 1/2" NPTF
- ③ Return Line Filter (optional)
- ④ Oil Sight Gauge
- ⑤ Roll Cage (optional)
- ⑥ Oil Drain
- ⑦ Lifting eyes (optional)
- ⑧ Handles
- ⑨ Skid Bar (Modelnr. SBZ-4) (optional)

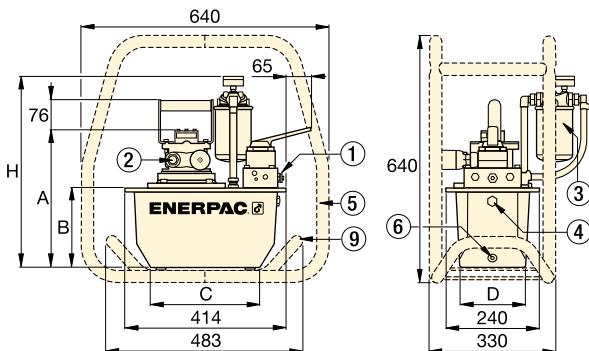

ZA4-Series Pumps with 4 - 8 litres reservoir

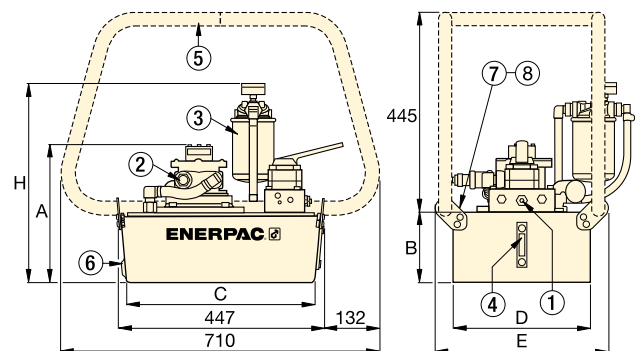

ZA4-Series Pumps with 10, 20 and 40 litres reservoir

Sound Level	Motor Size	Dimensions (mm)							Model Number
		A	B	C	D	E	H		
(dBA)	(kW)							(kg)	
80 - 95	3,0	295	142	279	152	-	429	27	ZA4004NX <sup>2)</sup>
80 - 95	3,0	295	142	279	152	-	429	30	ZA4204MX
80 - 95	3,0	356	203	279	205	-	490	34	ZA4308MX
80 - 95	3,0	330	180	414	421	500	467	51	ZA4610MX
80 - 95	3,0	295	142	279	152	-	429	31	ZA4404MX
80 - 95	3,0	356	203	279	205	-	490	35	ZA4408MX
80 - 95	3,0	305	155	419	305	384	442	40	ZA4810MX
80 - 95	3,0	330	180	414	421	500	467	52	ZA4420MX
80 - 95	3,0	419	269	399	505	584	556	75	ZA4440MX

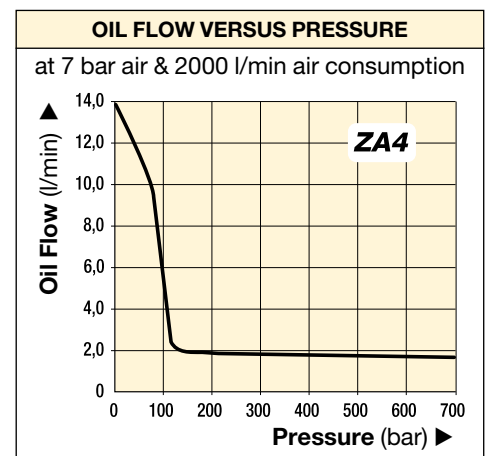

# ATP-Series, Ultra-High Pressure Air Pump

▼ Shown: ATP-1500



## ATP Series

Reservoir Capacity:  
**3,8 litres**

Flow at Rated Pressure:  
**0,07 l/min**

Maximum Operating Pressure:  
**1500 bar**

### OIL FLOW VERSUS PRESSURE

Flow (l/min) at 6,2 bar air input

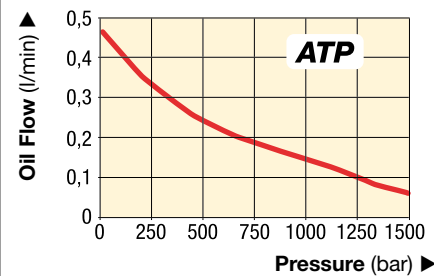

- General purpose, high pressure air driven two speed pump unit for products requiring up to 1500 bar hydraulic pressure
- Compact, lightweight, rugged steel frame for protection and easy handling
- Prelubricated pump element, does not require an airline lubricator
- Easily adjustable output pressure control
- Integrated and protected easy to read glycerin filled gauge
- Safety relief valve limits output pressure.

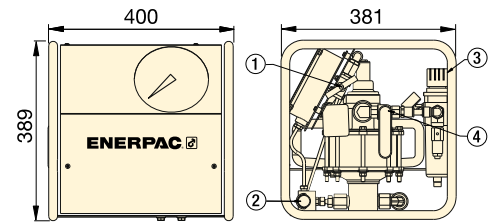





- ① Shut-off Valve
- ② Out Port 1/4" NPTF
- ③ Filter/Regulator
- ④ Air On/Off Valve  
Air Inlet 1/2" NPTF

### 1500 bar HIGH PRESSURE AIR PUMP

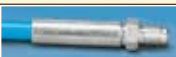

Pump Type	Useable Oil Capacity (litres)	Pressure Rating (bar)	Model Number	Output Flow Rate at 0 bar (l/min)	Output Flow Rate at 1500 bar (l/min)	Air Pressure Range (bar)	Air Consumption (l/min)	Sound Level (dBA)	 (kg)
Two speed	3,8	1500	<b>ATP-1500</b>	0,43	0,07	5,5 - 6,2	594	70	32

### 1500 bar HOSES

Model Number		Hose End 1	Hose End 2	Length (m)
HT-1503		1/4" BSPM 120° Cone	1/4" BSPM 120° Cone	1,0
HT-1510		1/4" BSPM 120° Cone	1/4" BSPM 120° Cone	3,0
HT-1503HR*		BH-150	BR-150	1,0
HT-1510HR*		BH-150	BR-150	3,0

\* Includes dust caps.

### 1500 bar COUPLERS

Description		Complete Set	Female Half	Male Half
Quick Disconnect Coupler*		B-150	BR-150	BH-150
Quick Disconnect Coupler and Adaptor Kit*		BW-150AW	-	-
Quick Disconnect Blanking Coupler Set*		B-150B	-	-

\* Includes dust caps.

# PGM-Series, Gasoline Hydraulic Pumps

▼ Shown: **PGM-2408R**



## PGM Series



Reservoir Capacity:

**4 and 8 litres**

Flow at Rated Pressure:

**0,66 l/min**

Motor Size:

**2,2 kW**

Maximum Operating Pressure:

**700 bar**



### Hoses

Enerpac offers a complete line of high quality hydraulic hoses. To ensure the integrity of your system, specify only Enerpac hydraulic hoses.

Page: 120

- **Patented Genesis Technology means**
  - coaxial piston design ensures high performance
  - first-stage piston pump for improved efficiency
- **High by-pass pressures improve productivity**
- **All Atlas pumps feature sturdy roll cage for use in tough environments**
- **Four-cycle Honda motor 2,2 kW.**

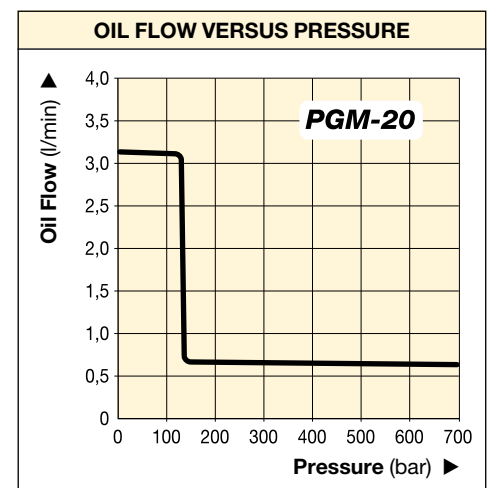
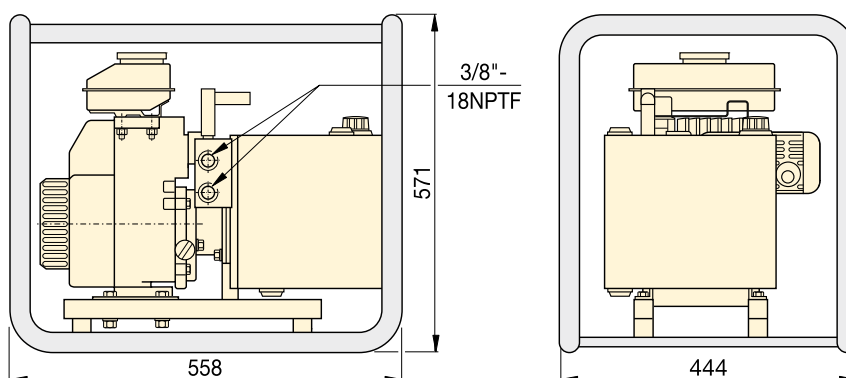

Used with Cylinder	Usable Oil Capacity (litres)	Model Number	Pressure Rating (bar)	Output Flow Rate (l/min)		By-Pass Pressure (bar)	Manual Valve Type	Valve Function	Sound Level (dBA)	Weight (kg)
				1 <sup>st</sup> stage	2 <sup>nd</sup> stage					
Single-Acting	3,8	PGM-2304R*	700	3,2	0,66	140	3/3	Advance/Hold/Retract	89	25
Double-Acting	3,8	PGM-2404R*	700	3,2	0,66	140	4/3	Advance/Hold/Retract	89	25
Single-Acting	7,6	PGM-2308R*	700	3,2	0,66	140	3/3	Advance/Hold/Retract	89	33
Double-Acting	7,6	PGM-2408R*	700	3,2	0,66	140	4/3	Advance/Hold/Retract	89	33

\* Note: The PGM-20 series are available with a carrying handle instead of a roll cage. For ordering omit the 'R' from the model number



▼ Shown: ZG5420MX-R



## Z CLASS

**Tough, Dependable,  
Innovative**

- Features Z-Class high efficiency pump design, higher oil flow and bypass pressure
- Two-speed operation reduces cycle time for improved productivity
- User adjustable relief valve built-in on manual valves. Oil ports on valves are 3/8" NPTF
- Available in two 4-cycle engine sizes: 4,1 kW Honda and 4,8 kW Briggs & Stratton
- Full sight oil level glass on all reservoirs allow quick and easy oil level monitoring.



### Speed Chart

To determine how a specific pump will operate your cylinder, see the Pump-Cylinder Speed Chart in the 'Yellow Pages'.

Page: **249**



### ZG-Series, Gasoline Pump Performance

Elevation can affect the performance of any gasoline engine. ZG-Series pumps are designed to develop rated performance at elevations up to 1500 m. For applications above this elevation, please consult your Enerpac office.



### User Adjustable Relief Valve

All VM-Series directional valves have a user adjustable relief valve to allow the operator to easily set the optimum working pressure.

Page: **114**

### ▼ SELECTION CHART

Used with Cylinder	Usable Oil Capacity (litres)	Manual Valve <sup>1)</sup> Model Number	Valve Function	Model Number with Roll Cage	Output Flow Rate (l/min)				4-Cycle Engine Type and Size
					at 7 bar	at 50 bar	at 350 bar	at 700 bar	
Single-Acting	10	VM33	Advance/Hold/Retract	ZG5310MX-R	11,5	10,7	1,8	1,6	Honda 4,1 kW
	20	VM33	Advance/Hold/Retract	ZG5320MX-R	11,5	10,7	1,8	1,6	
Double-Acting	10	VM43	Advance/Hold/Retract	ZG5410MX-R	11,5	10,7	1,8	1,6	
	20	VM43	Advance/Hold/Retract	ZG5420MX-R	11,5	10,7	1,8	1,6	
Single-Acting	10	VM33	Advance/Hold/Retract	ZG5310MX-BR	6,5	6,2	1,8	1,6	Briggs & Stratton 4,8 kW
	20	VM33	Advance/Hold/Retract	ZG5320MX-BR	6,5	6,2	1,8	1,6	
Double-Acting	10	VM43	Advance/Hold/Retract	ZG5410MX-BR	6,5	6,2	1,8	1,6	
	20	VM43	Advance/Hold/Retract	ZG5420MX-BR	6,5	6,2	1,8	1,6	
	40	VM43L	Advance/Hold/Retract	ZG5840MX-BR	6,5	6,2	1,8	1,6	

<sup>1)</sup> See pages 114-116 for hydraulic symbols of these valves.

# Gasoline Hydraulic Pumps

▼ This is how a ZG-Series pump model number is built up:

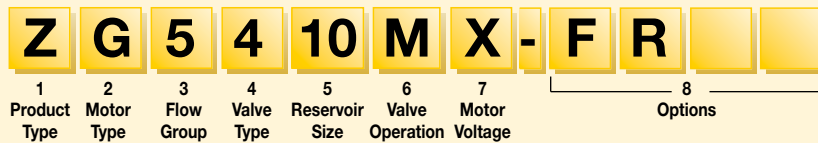

### 1 Product Type

**Z** = Pump Class

### 2 Prime Mover

**G** = Gasoline Engine

### 3 Flow Group

**5** = 1,6 l/min @ 700 bar

**6** = 3,3 l/min @ 700 bar (see page 112)

### 4 Valve Type

**0** = No valve, with cover plate <sup>1)</sup>

**2** = 3/2 manual valve **VM32**

**3** = 3/3 manual valve **VM33**

**4** = 4/3 manual valve **VM43**

**6** = 3/3 manual locking valve **VM33L** with pilot operated check

**8** = 4/3 manual locking valve **VM43L** with pilot operated check.

<sup>1)</sup> For remote valve mounting order **BSS1090** high pressure connecting plate.

### 5 Reservoir Size, useable oil

**10** = 10 litres

**20** = 20 litres

**40** = 40 litres

### 6 Valve Operation

**M** = Manual valve

**N** = No valve

### 7 Motor Voltage

**X** = Not applicable

### 8 Factory installed options

**B** = Briggs & Stratton gasoline engine

**F** = Return Line Filter

**G** = 1000 bar pressure gauge

**N** = No reservoir handles (includes lifting eyes on 10, 20 and 40 litres)

**R** = Roll Cage

### Ordering Example

Model Number: **ZG5420MX-FR**

This is a 700 bar hydraulic pump, with a 4/3 manual valve, 20 litres reservoir, with a 4,1 kW Honda gasoline engine pump, return line filter and roll bar.

## ZG5 Series



Reservoir Capacity:

**10 - 20 - 40 litres**

Flow at Rated Pressure:

**1,6 l/min**

Engine Size:

**4,1 - 4,8 kW**

Maximum Operating Pressure:

**700 bar**



### High Pressure Hoses

Enerpac offers a complete line of high quality hydraulic hoses. To ensure the integrity of your system, specify only genuine Enerpac hydraulic hoses.

Page: **120**

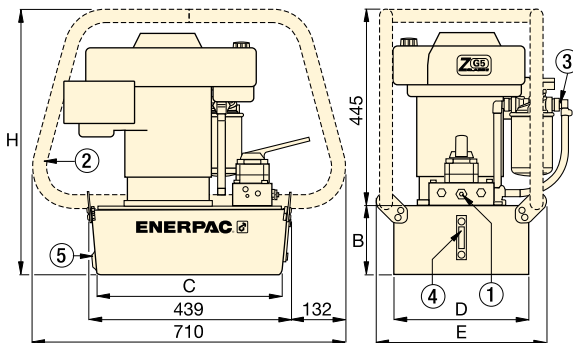

① User adjustable relief valve on all manual valves. 3/8" NPTF on A and B ports; 1/4" NPTF on auxiliary ports.

- ② Roll Bar
- ③ Return Line Filter
- ④ Oil Level Gauge
- ⑤ Oil Drain

### ZG6-Serie 9,7 kW Pump

The ZG6-pump has 3,3 l/min oil flow at 700 bar, Briggs & Stratton 4-cycle gasoline engine with electric start and 12 Volt charge output for accessories.

Page: **112**

Relief Valve Adjustment Range (bar)	Sound Level (dBA)	Dimensions (mm)						Model Number with Roll Cage (kg)
		B	C	D	E	H		
70 - 700	88 - 93	155	419	305	384	600	52	<b>ZG5310MX-R</b>
70 - 700	88 - 93	180	414	421	500	625	64	<b>ZG5320MX-R</b>
70 - 700	88 - 93	155	419	305	384	600	52	<b>ZG5410MX-R</b>
70 - 700	88 - 93	180	414	421	500	625	64	<b>ZG5420MX-R</b>
70 - 700	91 - 95	155	419	305	384	600	50	<b>ZG5310MX-BR</b>
70 - 700	91 - 95	180	414	421	500	625	63	<b>ZG5320MX-BR</b>
70 - 700	91 - 95	155	419	305	384	600	50	<b>ZG5410MX-BR</b>
70 - 700	91 - 95	180	414	421	500	625	63	<b>ZG5420MX-BR</b>
70 - 700	91 - 95	269	399	505	557	714	86	<b>ZG5840MX-BR</b>

### OIL FLOW VERSUS PRESSURE

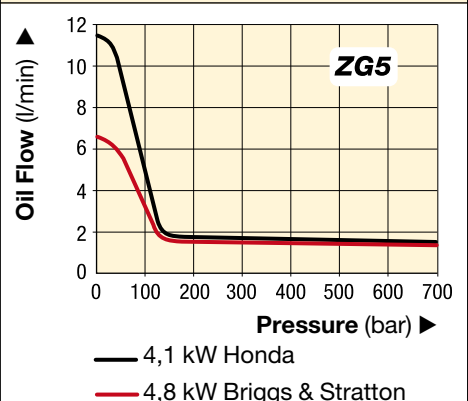

# ZG6-Series, Gasoline Hydraulic Pump

▼ Shown: ZG6440MX-BCFH



## ZG6 Series

Reservoir Capacity:  
**40 litres**

Flow at Rated Pressure:  
**3,3 l/min**

Engine Size:  
**9,7 kW**

Maximum Operating Pressure:  
**700 bar**

**Z** Tough  
Dependable  
Innovative  
**CLASS**

- Features Z-Class high efficiency pump design:
  - higher oil flow and bypass pressure
  - patented balanced rotating pump components to reduce vibration
  - replaceable piston check valves that increase service life of pump components
- Two-speed operation reduces cycle time for improved productivity
- Easy serviceable 9,7 kW, 4-cycle gasoline engine with electric start and 12 Volt charge output for accessories.
- Dual forced air heat exchangers stabilizes hydraulic oil temperature
- Roll cage for easy portability and hoisting, protects pump
- Sturdy wheeled cart with collapsible handles
- Fullsight oil level-glass for easy oil level monitoring.



### Speed Chart

To determine how a specific pump will operate your cylinder, see the Pump-Cylinder Speed Chart in the 'Yellow Pages'.

Page: **249**



### Adjustable Pressure Relief Valve

ZG-Series pumps have a manual directional control valve with a user adjustable relief valve to allow the operator to easily set the optimum working pressure. Relief valve adjustment range 70-700 bar. Oil ports are 3/8" NPTF.

## ▼ SELECTION CHART

For use with cylinder	Usable Oil Capacity (litres)	Manual Control Valve Type	Valve Function	Model Number	Output Flow Rate (l/min)		4-Cycle Engine Size (kW)	Outside Dimensions L x B x H (mm)	 (kg)
					at 7 bar	at 700 bar			
Dbl-Act.	40	4/3	Adv./Hold/Retr.	ZG6440MX-BCFH	14,7	3,3	9,7	1205 x 840 x 935	152

# Directional Control Valves Section Overview

ENERPAC hydraulic valves are available in a wide variety of models and configurations.

Whatever your requirements... directional control, flow control, or pressure control... you can be sure that Enerpac has the correct valve to match your application exactly.

Designed and manufactured for safe operation up to 700 bar, the range of Enerpac valves allows for direct pump mounting, remote mounting, manual or solenoid actuation, and in-line installation, giving you flexible solutions to control your hydraulic system.

Valve Type	Series	Page
Pump Mounted Manual and Solenoid Directional Control Valves	VM VE	114 ▶
Remote Mounted Manual Directional Control Valves Valve Dimensions	VC	116 ▶
Valve Dimensions	VM VE VC	117 ▶



### Pressure and Flow Control Valves

For more hydraulic system control with pressure relief valves, shut-off valves, check valves and sequence valves see our "System Components".

Page: 134



### Valving Help

See Basic System Set-Up and Valve Information in our 'Yellow Pages'

Page: 250





▼ Shown from left to right: VM32, VE33, VM33, VM43L



- Advance/Retract and Advance/Hold/Retract operation of single-acting and double-acting cylinders and tools
- Manual or solenoid operation
- Pump mounting will retrofit on most Enerpac pumps
- Available “locking” option on VM Series valves for load-holding applications
- Standard “locking” feature on VE Series 3-position valves
- User adjustable relief valve allows the operator to easily set the working pressure.

▼ ZE-Series electric pump, with VM43 directional valve coupled to a A-65 distribution manifold with V-82 needle valves to operate double-acting jacks in a lifting job.



## Reliable Control of Single and Double-Acting Cylinders and Tools

Valve Operation	Used with Cylinder	Valve Type	
Manual	Single-acting	3-Way, 2-Position	
Manual	Single-acting	3-Way, 3-Position, Tandem Center	
Manual	Double-acting	4-Way, 3-Position, Tandem Center	
Manual	Single-acting	3-Way, 3-Position, Tandem Center, Locking	
Manual	Double-acting	4-Way, 3-Position, Tandem Center, Locking	
Solenoid 24 VDC	Single-acting	3-Way, 2-Position	
Solenoid 24 VDC	Single-acting	3-Way, 2-Position, Dump	
Solenoid 24 VDC	Single-acting	3-Way, 3-Position, Tandem Center	
Solenoid 24 VDC	Double-acting	4-Way, 3-Position, Tandem Center	

For remote valve information, see page 116.

# Pump Mounted Directional Control Valves



## Adjustable relief valve

All valves feature several gauge ports for "system", A port and B port pressure monitoring. User adjustable relief valves are included on all models to allow the operator to easily set the optimum working pressure for each application.

VM33 and VE43 valves include "System Check" feature, for more precise pressure holding and improved system control. The VM33 has improved porting which provides faster cylinder retraction while motor is running.

## VM VE Series



Flow Capacity:  
**17 l/min**

Maximum Operating Pressure:  
**700 bar**

Model Number	Hydraulic Symbol	Schematic Flowpath			Weight (kg)
		Advance	Hold	Retract	
VM32					2,5
VM33					3,0
VM43					3,1
VM33L					4,8
VM43L					4,9
VE32					3,9
VE32D					3,9
VE33					9,3
VE43					9,3

See page 117 for valve dimensions.



## Fittings

For additional fittings see the fitting page of the System Components section in this catalogue.

Page: 125



## Locking Valves

For applications that require positive load holding, VM-Series valves (except VM32 valve) are available with a pilot-operated check valve. This option provides hydraulic locking of the load until the valve is shifted into the retract position.



## Pendants for VE-Series Solenoid Valves

When ordering Enerpac VE-Series solenoid valves, the pendant must be ordered separately for Z-Class. Pendant connection to be plugged into electric box of pump.

To be used with solenoid valves:	Pendant Model Nr.
VE32D	ZCP-1
VE32, VE33, VE43	ZCP-3

Page: 95

▼ Shown from left to right: VC-20, VC-4L



## Remote Control of Single and Double-Acting Cylinders and Tools



### Locking Valves

For applications that require positive load holding, VC-Series valves are available with a pilot-operated check valve. This option provides hydraulic locking of the load until the valve is shifted into the retract position.

- Advance/Hold/Retract operation for use with single-acting or double-acting cylinders and tools.

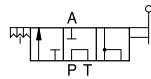
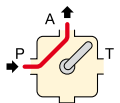
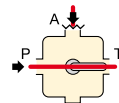
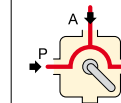
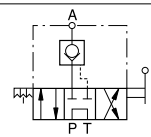
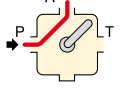
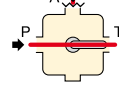
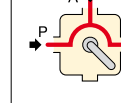
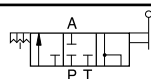
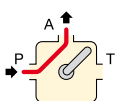
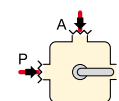
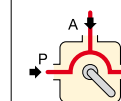
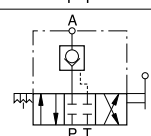
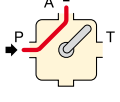
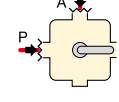
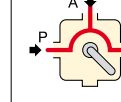
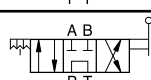
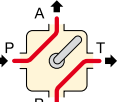
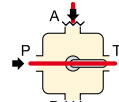
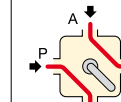
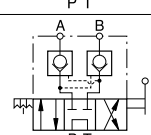
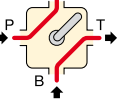
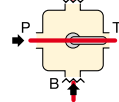
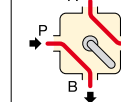
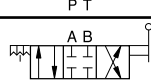
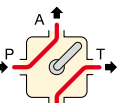
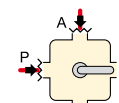
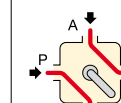
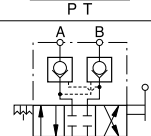
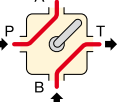
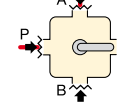
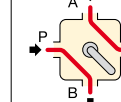
Valve Operation	Used with Cylinder	Valve Type	Model Number	Hydraulic Symbol	Schematic Flowpath			 (kg)
					Advance	Hold	Retract	
Manual	Single-Acting	3-Way, 3-Position, Tandem Center	<b>VC-3</b>					2,9
Manual	Single-Acting	3-Way, 3-Position, Tandem Center, Locking	<b>VC-3L</b>					4,7
Manual	Single-Acting	3-Way, 3-Position, Closed Center	<b>VC-15</b>					2,9
Manual	Single-Acting	3-Way, 3-Position, Closed Center, Locking	<b>VC-15L</b>					4,7
Manual	Double-Acting	4-Way, 3-Position, Tandem Center	<b>VC-4</b>					2,9
Manual	Double-Acting	4-Way, 3-Position, Tandem Center, Locking	<b>VC-4L</b>					4,7
Manual	Double-Acting	4-Way, 3-Position, Closed Center	<b>VC-20</b>					2,9
Manual	Double-Acting	4-Way, 3-Position, Closed Center, Locking	<b>VC-20L</b>					4,7

Return line kit included with remote valves

# Directional Control Valves Dimensions

## Pump Mounted Directional Control Valves

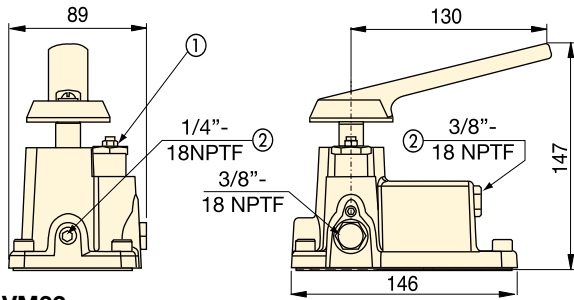

**VM32**

- ① User Adjustable Relief Valve
- ② Auxiliary Port

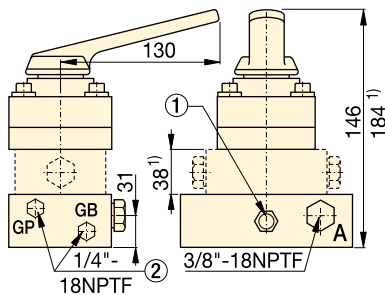

**VM33, VM33L, VM43, VM43L**

<sup>1)</sup> VM33L and VM43L only

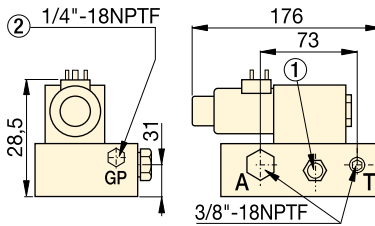

**VE32D**

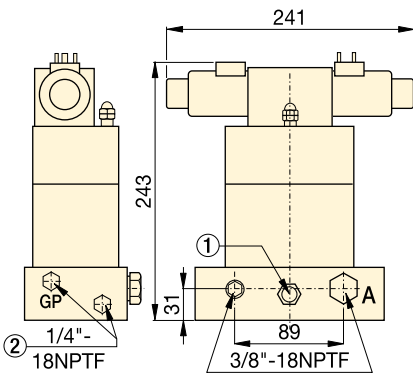

**VE33**

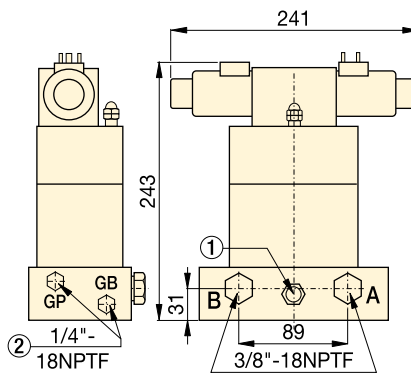

**VE43**

## Remote Manual Directional Control Valves

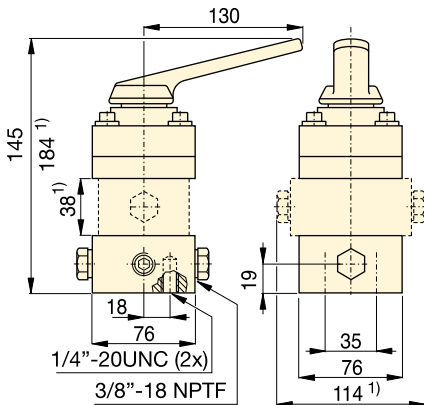

**VC-3, VC-3L, VC-15, VC-15L**

**VC-4, VC-4L, VC-20, VC-20L**

<sup>1)</sup> VC-3L, VC-15L, VC-4L and VC-20L only

## VM VE VC Series



Flow Capacity:  
**17 l/min**

Maximum Operating Pressure:  
**700 bar**



### Gauges

Minimize the risk of overloading and ensure long, dependable service from your equipment. Refer to the

System Components Section for a full range of gauges.

Page: **128**



### Fittings

For additional fittings see the fitting page of the System Components section in this catalogue.

Page: **125**



### Valving Help

See Basic System Set-Up and Valve Information in our 'Yellow Pages'

Page: **250**



# System Components & Valves

## ENERPAC System Components:

All the additional elements you need to complete your high pressure hydraulic system and get started.

Engineered to work with your Enerpac cylinders, pumps and tools, all Enerpac components are designed to the most exacting standards.

With this complete line of hydraulic hoses, couplers, fittings, manifolds, oil and gauges, Enerpac has the accessories to complement your system and ensure the efficient operation, long life and safety of your hydraulic equipment.



### Yellow Pages

For sample system set-ups and how to correctly specify your system components, please view the Enerpac “Yellow Pages” section in this catalogue.

Page: **239**















### Maintain System Integrity

Use Enerpac System Components, designed to interface with Enerpac cylinders, pumps and tools to ensure your system operates at peak performance.



# System Components and Control Valves Overview

Component Type	Series		Page
<b>Hoses</b>	<b>H700</b>		<b>120</b> ▶
<b>Couplers</b>	<b>A, C, F, T</b>		<b>122</b> ▶
<b>Hydraulic Oil</b>	<b>HF</b>		<b>124</b> ▶
<b>Manifolds</b>	<b>A</b>		<b>124</b> ▶
<b>Control Manifolds</b>	<b>AM</b>		<b>124</b> ▶
<b>Fittings</b>	<b>BFZ FZ</b>		<b>125</b> ▶
<b>Force Gauges Pressure Gauges</b>	<b>GF GP</b>		<b>126</b> ▶
<b>Pressure Gauges, glycerine filled Pressure Gauges, dry</b>	<b>G H</b>		<b>128</b> ▶
<b>Test System Gauges</b>	<b>T</b>		<b>130</b> ▶
<b>Digital Pressure Gauges</b>	<b>DGR</b>		<b>131</b> ▶
<b>Gauge Accessories</b>	<b>GA NV V</b>		<b>132</b> ▶
<b>Pressure and Flow Control Valves</b>	<b>V</b>		<b>134</b> ▶

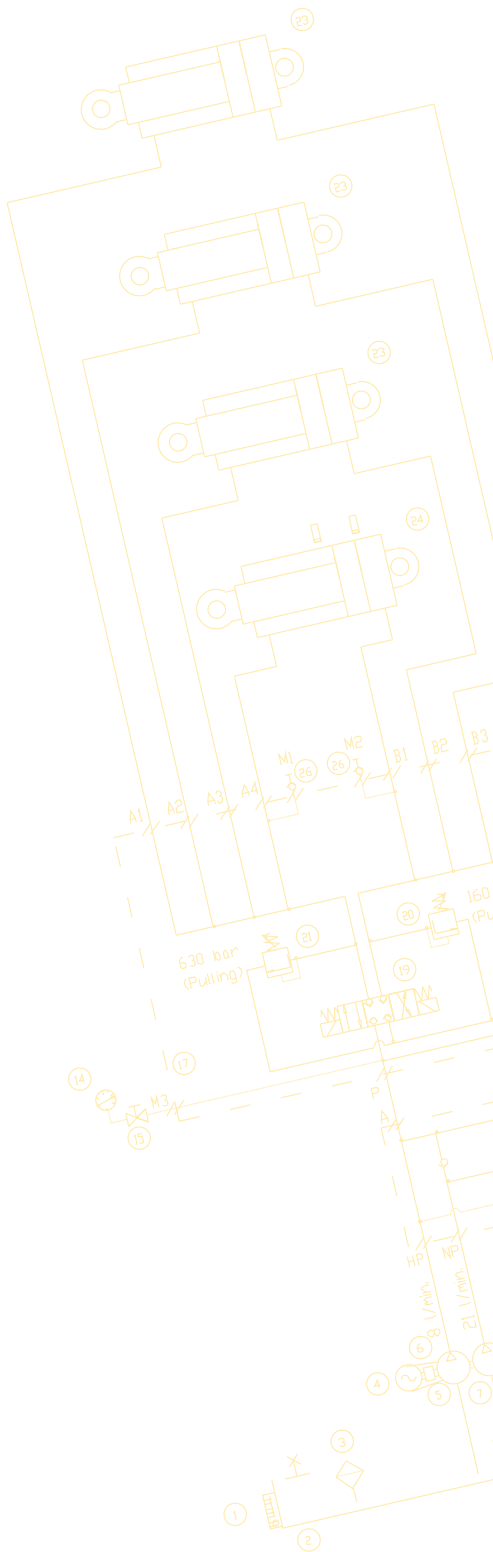

# H700-Series, High Pressure Hoses

▼ Shown from top to bottom: HA-7206B, HC-7206, H-7206



## Thermo-Plastic Safety Hoses (700-Series)

- For demanding applications, featuring a 4:1 safety factor
- Maximum working pressure of 700 bar
- Outside jacket is polyurethane, to provide maximum abrasion resistance
- Exhibits low volumetric expansion under pressure to enhance overall system efficiency
- Crimped-on rubber strain relief for improved life and durability on all models.

▼ To prevent back pressure and to increase cylinder retraction speed, when using long hoses with single-acting cylinders, the Enerpac HC-7300-Series of hoses with increased internal diameter is the best choice.



## Safety and Quality



To ensure the integrity of your system, specify only Enerpac hydraulic hoses.









### WARNING !

- Do not exceed 700 bar maximum pressure.
- Do not handle hoses which are under pressure.

More safety instructions in our 'Yellow pages'.

Page: **240**

### ▼ Hose End Couplings

1/4" NPTF	
3/8" NPTF	
A-604	
A-630	
AH-604	
AH-630	
C-604	
CH-604	

# High Pressure Hydraulic Hoses

## H700 Series



Inside Diameter:

**6,4 and 9,7 mm**

Length:

**0,6 - 15 m**

Maximum Operating Pressure:

**700 bar**

Internal Diameter (mm)	Hose End Assemblies and Couplers*		Hose Length (m)	Model Number	kg		
	End one	End two					
6,4	1/4" NPTF			-			
				-			
		A-630	1,8	HB-7206QB	1,1		
		CH-604	1,8	HC-7206Q	1,0		
	3/8" NPTF	3/8" NPTF		0,6	H-7202	0,5	
				0,9	H-7203	0,7	
				1,8	H-7206	0,9	
				3,0	H-7210	1,4	
				6,1	H-7220	2,8	
				9,1	H-7230	4,5	
				15	H-7250	7,0	
		A-604	1,8	HA-7206B	1,1		
		3/8" NPTF					
			AH-604	1,8	HA-7206	1,0	
				3,0	HA-7210	1,5	
			AH-630	1,8	HB-7206	1,0	
			C-604		0,9	HC-7203B	1,0
					1,8	HC-7206B	1,3
				3,0	HC-7210B	1,8	
	CH-604		0,9	HC-7203	0,8		
			1,8	HC-7206	1,0		
		3,0	HC-7210	1,5			
		6,1	HC-7220	2,9			
CH-604	CH-604		1,8	HC-7206C	1,1		
			15	HC-7250C	7,0		
9,7	3/8" NPTF	3/8" NPTF	1,8	H-7306	1,6		
				-	-	-	
				3,0	H-7310	2,4	
				6,1	H-7320	4,5	
				9,1	H-7330	7,3	
				15	H-7350	11,5	
		CH-604		1,8	HC-7306	1,7	
				3,0	HC-7310	2,5	
				6,1	HC-7320	5,1	

\* For technical information on couplers see next page.



### Torque Wrench Hoses

Use Enerpac twin safety hoses with double-acting wrenches to ensure the integrity of your hydraulic system.

Page: 202



### Fittings

For additional fittings see the fitting page of the System Components section.

Page: 125

### Hose Oil Capacity

When using greater hose lengths, it is sometimes necessary to fill the pump reservoir after filling the hoses. To determine the hose oil capacity, use the following:

For 6,4 mm inside diameter hoses:  
Capacity (cm<sup>3</sup>) = 32,1699 x Length (m)

For 9,7 mm inside diameter hoses:  
Capacity (cm<sup>3</sup>) = 73,8981 x Length (m)



# A, C, F, T-Series, Hydraulic Couplers

▼ Shown: FH-604, FR-400, AR-630, C-604, AH-604, AR-400



## 3/8" High Flow Couplers

- Standard equipment on most Enerpac cylinders
- Recommended for use on all Enerpac pumps and cylinders where space and porting permits
- Includes "2-in-1" dust cap for use on male and female couplers

## 3/8" High Pressure 'Flush-face' Couplers

- Featuring "Push-to-connect" operation, to guarantee good connection every time
- Flush-face, zero-leak operation for minimal spillage
- HTMA\* recognized for safety and performance
- Will not interchange with low pressure couplers

## 3/8" Regular Spee-D-Couplers®

- For medium duty applications with hand pumps
- Includes female aluminium dust cap

## 1/4" Regular Couplers

- For use with small cylinders and hand pumps
- Includes female aluminium dust cap

## 1/4" Spin-on Torque Wrench Couplers

- For use with 700 bar S and W-Series torque wrenches, THQ-Series hoses and 700 bar torque wrench pumps

## 1/4" Lock-ring Torque Wrench Couplers

- For use with 800 bar HXD and SQD-Series torque wrenches, THC-Series hoses and 800 bar torque wrench pumps.

\* Hydraulic Tool Manufacturers Association.

## Quick Connection of Hydraulic Lines



### Thread sealer

To seal NPTF threads use one of the new anaerobic thread sealers or Teflon paste.

When using Teflon Tape, apply the tape one thread from the end of a fitting to prevent it from winding up in the hydraulic system.



### WARNING!

**Couplers should be pressurized only when completely connected and should not be coupled or uncoupled when pressurized.**

More safety instructions in our 'Yellow Pages'.

Page: **240**



### F-Series

Flush-faced couplers provide reduced pressure drop versus other types and are preferred in dirty, grimy construction and mining environments due to easy clean, non-dirt trapping faces.

▼ With the use of Enerpac High Flow Couplers, hoses are easily installed for multiple hydraulic line connections in this 34 points PLC-controlled lifting system.



# Hydraulic Couplers



## CT-604 Safety Tool

Use the Enerpac CT-604 to relieve hydraulic back pressure by safely bleeding the hydraulic coupler.

Minimize injuries from projectile parts and under-skin hydraulic fluid injections by eliminating unsafe coupler bleeding practices.

**NOTE:** For use on C-Series 700 bar High-Flow Couplers only

The CT-604 is Enerpac-engineering safe for use at 700 bar.

## A, C, F, T Series



Maximum Flow Capacity:

**6,1 - 40,0 l/min**

Thread:

**1/4" and 3/8" NPTF**

Maximum Operating Pressure:

**700 and 800 bar**

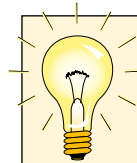
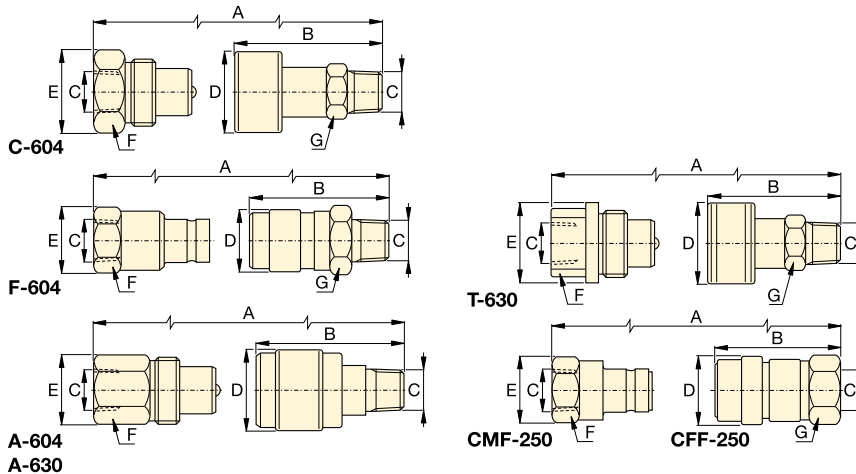

### Metal Dust Caps

Steel dust caps are available for the C-604 series couplers.

Order model number:

**CD-411M** for female half

**CD-415M** for male half

Maximum Flow Capacity (l/min)	Coupler Type	Model Numbers			Dimensions (mm)							Dust Cap(s)
		Complete Set	Female Half	Male Half	A*	B	C	D	E	F	G	
35	700 bar High-Flow Coupler 	C-604	CR-400	CH-604	83	64	3/8" NPTF	35	36	32	25	(2x) CD-411
40	700 bar Flush-Face coupler 	F-604	FR-400	FH-604	110	72	3/8" NPTF	31	31	26	28	-
7,6	700 bar Regular Spee-D-Coupler® 	A-604	AR-400	AH-604	77	42	3/8" NPTF	28	26	23	19	Z-410 female only
7,6	700 bar Regular Coupler 	A-630	AR-630	AH-630	66	35	1/4" NPTF	22	20	19	15	Z-640 female only
11,4	700 bar Spin-on Coupler 	T-630	TR-630	TH-630	73	60	1/4" NPTF	29	29	19	21	-
6,1	800 bar Lock-ring Coupler 	-	CFF-250	CMF-250	76	58	1/4" NPTF	23	28	24	22	-

\* Value A is total length when male and female half are connected.

▼ Shown: A-65, FZ-1625, HF-95Y, FZ-1634, FZ-1607, A-64, AM-21



## The Genuine Range

### Hydraulic Oil

Contents	Model Number	Use only genuine Enerpac Hydraulic Oil. The use of any other fluid will render your Enerpac warranty null and void.
1 litre	<b>HF-95X</b>	
5 litres	<b>HF-95Y</b>	
60 litres	<b>HF-95Z</b>	

### ▼ OIL SPECIFICATION CHART

Viscosity Index	100 min
Viscosity at 210°F	42/45 S.U.S.
Viscosity at 100°F	150/165 S.U.S.
Viscosity at 0°F	<12,000 S.U.S.
API Gravity	31.0/33.0
Flash, C.O.C. °F	400
Pour Point, °F	-25
Aniline Point, °F	210/220
Paraffinic Base Colour	Blue

- Maximum pump volumetric efficiency
- Maximum internal heat transfer
- Prevents pump cavitation
- Additives prevent rust, oxidation and sludge
- High viscosity index
- Maximum film protective lubricity

## Manifolds

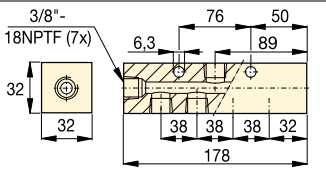
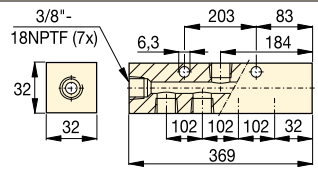
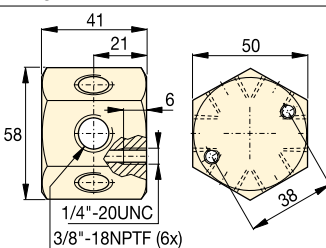
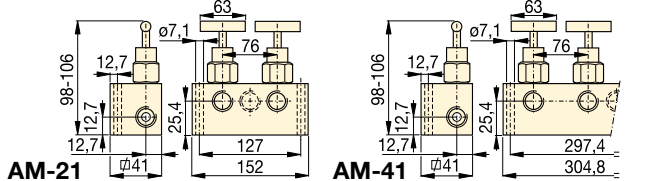
Description	Model Nr.	Dimensions (mm)
<b>7-port Manifold, short</b>	<b>A-64</b>	
<b>7-port Manifold, long</b> allows direct mounting of control valves to the manifold.	<b>A-65</b>	
<b>6-port Manifold, hexagon</b> Plugs furnished for all ports 3/8\"-18 NPTF.	<b>A-66</b>	
<b>Control Manifolds</b> For control of two or four single-acting cylinders simultaneously. AM-21 with 5 ports 3/8\" NPTF. AM-41 with 7 ports 3/8\" NPTF.	<b>AM-21</b> <b>AM-41</b>	

# Hydraulic Oil, Manifolds and Fittings











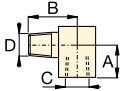

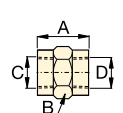

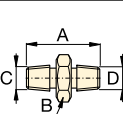

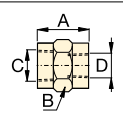

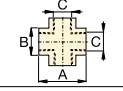

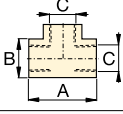

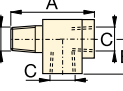

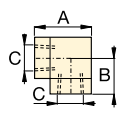
## 3/8" Swivel Connector

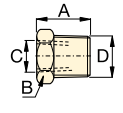
360 degree swivel coupler for optimal orientation of the hydraulic connection on cylinders, pumps and hoses. Order Model Nr. **XSC-1**.

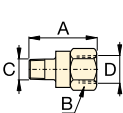
## A, AM BFZ FZ HF Series

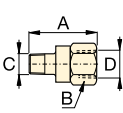

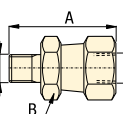
Fittings 700 bar		Model Number	Dimensions (mm)				Diagram	
			A	B	C	D		
<b>Street Elbow</b>			<b>FZ-1616</b>	23	33	3/8"-18 NPTF	3/8"-18 NPTF	
From: 3/8"-NPTF Male	To: 3/8"-NPTF Female							
<b>Reducing Connector</b>			<b>FZ-1615</b>	28	25	3/8"-18 NPTF	1/4"-18 NPTF	
From: 3/8"-NPTF Female	To: 1/4"-NPTF Female							
From: 1/2"-NPTF Female	To: 3/8"-NPTF Female		<b>FZ-1625</b>	47	29	1/2"-14 NPTF	3/8"-18 NPTF	
<b>Hexagon Nipple</b>			<b>FZ-1608</b>	38	16	1/4"-18 NPTF	1/4"-18 NPTF	
From: 1/4"-NPTF	To: 1/4"-NPTF							
From: 3/8"-NPTF	To: 3/8"-NPTF		<b>FZ-1619</b>	51	19	3/8"-18 NPTF	3/8"-18 NPTF	
From: 3/8"-NPTF	To: 3/8"-NPTF	<b>FZ-1617</b>	37	19	3/8"-18 NPTF	3/8"-18 NPTF		
<b>Coupling</b>			<b>FZ-1614</b>	29	23	3/8"-18 NPTF	3/8"-18 NPTF	
From: 3/8"-NPTF	To: 3/8"-NPTF							
From: 1/4"-NPTF	To: 1/4"-NPTF	<b>FZ-1605</b>	29	19	1/4"-18 NPTF	1/4"-18 NPTF		
<b>Cross</b>			<b>FZ-1613</b>	45	25	3/8"-18 NPTF	-	
From: 3/8"-NPTF Female	To: 3/8"-NPTF Female							
<b>Tee</b>			<b>FZ-1612</b>	45	25	3/8"-18 NPTF	-	
From: 3/8"-NPTF	To: 3/8"-NPTF							
From: 1/4"-NPTF	To: 1/4"-NPTF	<b>FZ-1637</b>	45	24	1/4"-18 NPTF	-		
<b>Street Tee</b>			<b>BFZ-16312</b>	56	26	3/8"-18 NPTF	3/8"-18 NPTF	
From: 3/8"-NPTF Female	To: 3/8"-NPTF Male							
<b>Elbow</b>			<b>FZ-1610</b>	33	20	3/8"-18 NPTF	-	
From: 3/8"-NPTF	To: 3/8"-NPTF							
From: 1/4"-NPTF	To: 1/4"-NPTF	<b>FZ-1638</b>	36	24	1/4"-18 NPTF	-		
<b>Reducer</b>			<b>FZ-1630</b>	19	19	1/4"-18 NPTF	3/8"-18 NPTF	
From: 3/8"-NPTF	To: 1/4"-NPTF							
From: 1/4"-NPTF	To: 1/2"-NPTF		<b>BFZ-1630</b>	28	22	1/4"-18 NPTF	1/2"-14 NPTF	
From: 3/8"-NPTF	To: G1/4"	<b>BFZ-16301</b>	19	19	G1/4"	3/8"-18 NPTF		
<b>Adaptor</b>			<b>BFZ-16411</b>	35	19	1/4"-18 NPTF	G1/4"	
From: G1/4"	To: 1/4"-NPTF							
From: G1/4"	To: 1/8"-NPTF		<b>BFZ-16421</b>	31	19	1/8"-27 NPTF	G1/4"	
From: G3/8"	To: 1/4"-NPTF		<b>BFZ-16323</b>	43	24	1/4"-18 NPTF	G3/8"	
From: G3/8"	To: 3/8"-NPTF	<b>BFZ-16324</b>	43	24	3/8"-18 NPTF	G3/8"		
<b>Adaptor</b>			<b>FZ-1055</b>	44	23	1/4"-18 NPTF	1/4"-18 NPTF	
From: 1/4"-NPTF	To: 3/8"-NPTF							
From: 1/4"-NPTF	To: 1/8"-NPTF		<b>FZ-1642</b>	30	19	1/8"-27 NPTF	1/4"-18 NPTF	
From: 1/2"-NPTF	To: 3/8"-NPTF	<b>FZ-1634</b>	42	28	3/8"-18 NPTF	1/4"-18 NPTF		
<b>Swivel Fitting</b>			<b>FZ-1660</b>	40	22	3/8"-18 NPTF	1/2"-14 NPTF	
From: 3/8"-NPTF Male	To: 3/8"-NPTF Female							



# Hydraulic Force & Pressure Gauges

▼ Shown from left to right: GF-230B, GF-835B, GP-10S



- **GF-series gauges:** calibrated with dual scale reading for pressure and force in bar and kN
- **GF-series gauges:** all pressure sensing parts are sealed and damped by glycerine for long life
- **GP-series gauges:** calibrated with dual scale reading for pressure in bar and psi
- **Excellent readability:** gauge face dimensions 100 mm
- **Fast, easy installation**
- **Stainless steel gauge cases for corrosion resistance.**

▼ A GP-10S gauge is used on this press to check the hydraulic pressure required to bend flat steel bar.



## Visual Reference for System Pressure and Force



### Auto-Damper Valve V-10

For automatic control of gauge fluctuations, the **V-10** Auto-Damper Valve controls the movement of the gauge needle by restricting oil flow in and out of the gauge. No adjustments needed.



Page: 134



### Snubber Valve V-91

Infinitely adjustable for metering oil out of a gauge. The **V-91** Snubber Valve is also suitable as a shut-off valve to protect the gauge during high cycle applications.

Page: 134

	Used With
	All Cylinders
	All Cylinders
	All 5 ton Cylinders
	All 10 ton Cylinders
	All 25 ton RC-Cylinders
	All 50 ton RC, RR-Cylinders
	13 ton RCH-Series
	RCS-201, 302
	RCS-502, 1002
	RCH-202, 302, 603
All 25, 30, 50 ton cylinders	
All 75, 100 ton cylinders	
All 150, 200 ton cylinders	
	10 ton VLP Presses
	25 ton XLP Presses
	50 ton XLP, BPR Presses
	100 ton VLP, BPR Presses
	200 ton VLP, BPR Presses

# Hydraulic Force & Pressure Gauges



## Maximum Indicator Pointer

Indicator retains peak readings of pressure or force generated by the system.

Can easily be installed on GP and H-Series gauges.  
Order model nr: **BSA-881**.



## Pressure Gauges

To measure the input pressure into cylinders or high pressure systems. Also for all testing applications.

## Force Gauges

To measure external load supported by a cylinder or jack in kN. For pressing parts together under pre-determined loads, weighing, testing, etc.

**GP-Series** are dry gauges.

**GF-Series** are glycerine filled gauges.

## GF GP Series



Pressure Range:

**0 - 1000 bar**

Force Range:

**0 - 2000 kN**

Gauge Face Diameter:

**100 mm**

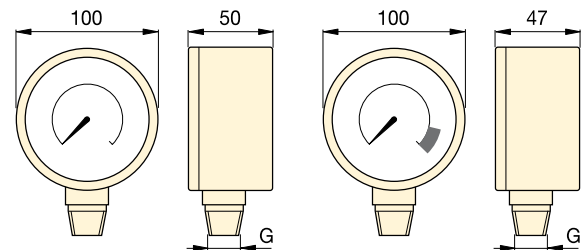

Accuracy, % of full scale:

**± 1%**



GP-serie

GF-serie

Gauge Type and Calibration				Units per Division	Model Number*	Thread G	Gauge Adaptor		
							 132		
bar	psi	bar	kN				Required		
							GA-1	GA-2	GA-3
0-700	0-10.000	-	-	10 bar, 100 psi	<b>GP-10S</b>	1/2" NPTF	●	●	
0-1000	0-15.000	-	-	10 bar, 200 psi	<b>GP-15S</b>	1/2" NPTF	●	●	
-	-	0-700	0-45	10 bar, 0,5 kN	<b>GF-5B</b>	1/2" NPTF	●	●	
-	-	0-700	0-100	10 bar, 1 kN	<b>GF-10B</b>	1/2" NPTF	●	●	
-	-	0-700	0-232	10 bar, 2 kN	<b>GF-20B</b>	1/2" NPTF	●	●	
-	-	0-700	0-500	10 bar, 5 kN	<b>GF-50B</b>	1/2" NPTF	●	●	
-	-	0-700	0-124	10 bar, 1 kN	<b>GF-120B</b>	1/2" NPTF	●	●	
-	-	0-700	0-175/275	10 bar, 2 + 5 kN	<b>GF-230B</b>	1/2" NPTF	●	●	
-	-	0-700	0-450/900	10 bar, 5 + 10 kN	<b>GF-510B</b>	1/2" NPTF	●	●	
-	-	0-700	0-210/320/570	10 bar, 5 kN	<b>GF-813B</b>	1/4" NPTF			●
-	-	0-700	0-232/300/500	10 bar, 5 kN	<b>GF-835B</b>	1/4" NPTF			●
-	-	0-700	0-720/930	10 bar, 10 kN	<b>GF-871B</b>	1/4" NPTF			●
-	-	0-700	0-1400/2000	10 bar, 25 kN	<b>GF-200B</b>	1/4" NPTF			●
-	-	0-700	0-100	10 bar, 1 kN	<b>GF-10B</b>	1/2" NPTF	●	●	
-	-	0-700	0-232	10 bar, 2 kN	<b>GF-20B</b>	1/2" NPTF	●	●	
-	-	0-700	0-500	10 bar, 5 kN	<b>GF-50B</b>	1/2" NPTF	●	●	
-	-	0-700	0-720/930	10 bar, 10 kN	<b>GF-871B</b>	1/4" NPTF			●
-	-	0-700	0-1400/2000	10 bar, 25 kN	<b>GF-200B</b>	1/4" NPTF			●

\* GF-Series Force gauges with imperial scale reading (psi, lbs) are available by changing the suffix 'B' into 'P'.

▼ Shown from left to right: H4049L, G-2534R, G-4089L, G-2535L, G-4040L



## Visual Reference of System Pressure

### Glycerine Filled (G-Series)

- Dual scale reading calibrated in bar and psi
- All pressure sensing parts sealed and dampened by glycerine for long life
- Includes safety blow-out disk and pressure equalizing membrane
- Gauge snubbers or needle valves recommended for high cycle applications.

### High Cycle Dry Gauges (H-Series)

- Dual scale reading calibrated in bar and psi
- Ideal for use in many applications, specifically for high cycle and harsh environments
- Gauge snubbers or needle valves recommended to shut off gauge when not in use.

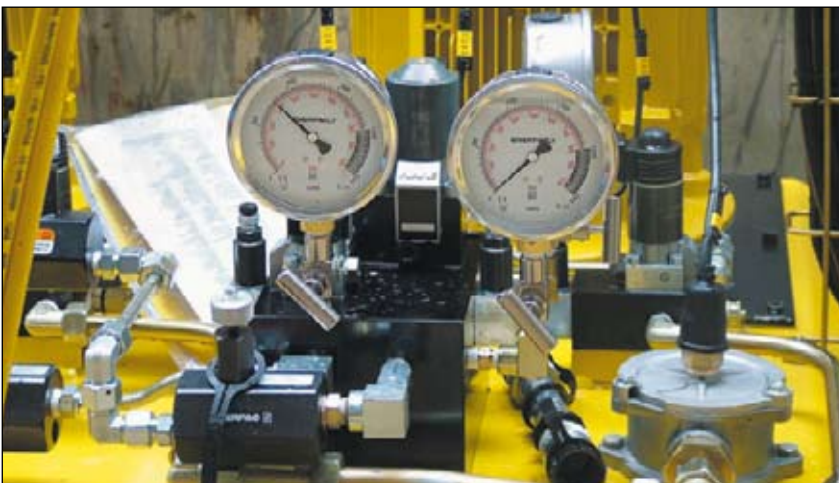

### Gauge adaptor

For easy gauge installation into almost any system, Enerpac offers a complete line of gauge adaptors.

Page: 132



### Snubber Valve V-91

Infinitely adjustable for metering oil out of a gauge. The V-91 Snubber Valve is also suitable as a shut-off

valve to protect the gauge during high cycle applications.

Page: 134

◀ When lifting or pressing, always use a gauge. A gauge is your 'window' to the system. It lets you see what's going on.

# Hydraulic Pressure Gauges

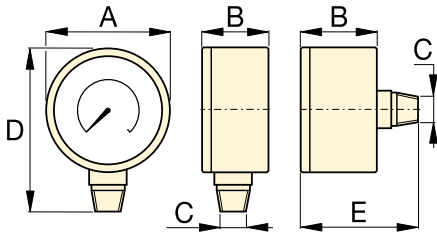

Dimensions (mm)						
Size	Connection	A	B	C	D	E
63	Lower Mount	63	37	1/4" NPTF	84	-
63	Center Rear	63	37	1/4" NPTF	-	63
100	Lower Mount	100	29	1/4" NPTF	121	-
100	Lower Mount	100	49	1/2" NPTF	136	-

Note: dimensions for reference only.

## G H Series



Pressure Range:

**0 - 1000 bar**

Face Diameter:

**63 - 100 mm**

Accuracy, % of full scale:

**± 1,0 - 1,5%**



### Maximum Indicator Pointer

Indicator retains peak readings of pressure or force generated by the system.

Can easily be installed on GP and H-Series gauges.

Order model nr: **BSA-881**.

## ▼ SELECTION CHART

Gauge Series	Pressure Range		Model Number				Major Graduation		Minor Graduation		Major Graduation		Minor Graduation	
			ø 63 1/4" NPTF Lower Mount	ø 63 1/4" NPTF Center Rear	ø 100 1/4" NPTF Lower Mount	ø 100 1/2" NPTF Lower Mount	bar		psi		psi		psi	
	(bar)	(psi)	Accuracy: ± 1,5 %		Accuracy: ± 1,0 %		ø 63	ø 100	ø 63	ø 100	ø 63	ø 100	ø 63	ø 100
<b>G-Series</b>	0-7	0-100	<b>G2509L</b>	-	-	-	1	-	0,01	-	10	-	2	-
	0-11	0-160	<b>G2510L</b>	-	-	-	1	-	0,02	-	10	-	2	-
	0-14	0-200	<b>G2511L</b>	-	-	-	1	-	0,02	-	50	-	5	-
	0-20	0-300	<b>G2512L</b>	-	-	-	5	-	0,50	-	50	-	5	-
	0-40	0-600	<b>G2513L</b>	-	-	-	10	-	1	-	100	-	10	-
	0-70	0-1.000	<b>G2514L</b>	<b>G2531R</b>	-	-	10	-	1	-	100	-	20	-
	0-140	0-2.000	<b>G2515L</b>	-	-	-	10	-	2	-	500	-	50	-
	0-200	0-3.000	<b>G2516L</b>	-	-	-	50	-	5	-	500	-	50	-
	0-400	0-6.000	<b>G2517L</b>	<b>G2534R</b>	-	-	100	-	10	-	1000	-	100	-
	0-700	0-10.000	<b>G2535L</b>	<b>G2537R</b>	<b>G4088L</b>	<b>G4039L</b>	100	100	10	10	2000	1000	200	100
0-1000	0-15.000	<b>G2536L</b>	<b>G2538R</b>	<b>G4089L</b>	<b>G4040L</b>	100	100	20	20	3000	3000	200	200	
<b>H-Series</b>	0-700	0-10.000	-	-	<b>H4049L</b>	<b>H4071L</b>	-	100	-	10	-	1000	-	100



# Test System Gauges

▼ Gauge shown: T-6003L



- Dual scale reading calibrated in bar and psi
- All gauges have spring-loaded backs with rubber blow-out plugs to protect case assembly in case of over-pressurization
- Integral maximum indicator pointer standard included
- 2800 and 3500 bar models include flange mounting
- 1/2" NPTF versions are made of high strength alloy steel
- 0.25" cone models are made of 316 stainless steel, with 403 stainless steel on 2800 and 3500 bar models.

▼ An Enerpac P-2282 hand pump equipped with a T-6011L test system gauge is used for proof pressure testing of hydraulic valves.



## T Series

Pressure Range:  
**0 - 3500 bar**

Face Diameter:  
**162 - 192 mm**

Accuracy, % of full scale:  
**±0,5 - 1,5%**



### Cone Mount Gauge Adaptor

Contains fittings to connect 1/4" cone fitting gauge to 3/8" cone system. Kit includes 43-301 tee and 43-704 gauge adaptor. Order model number: **83-011**.

Page: **75**



### Cone Mount Gauge Connector

For connecting gauges with 0.25" cone fitting directly to model number **11-100** or

**11-400** pump (page 74). May be used with other 0.25" cone systems  
Order model number: **43-704**

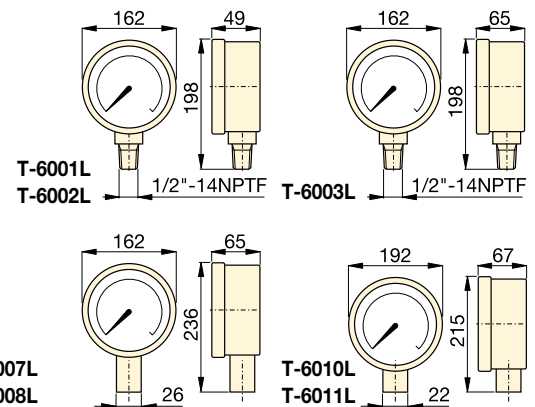

Pressure Range (bar)	Pressure Range (psi)	Model Number		Number Intervals (bar)	Graduation Intervals (bar)	Number Intervals (psi)	Graduation Intervals (psi)
		Alloy Steel 1/2" NPTF	Stainless Steel 0,25 cone				
0-70 <sup>1)</sup>	0-1000	<b>T-6001L</b>	–	10	1	100	10
0-350 <sup>1)</sup>	0-5000	<b>T-6002L</b>	–	50	5	500	50
0-700 <sup>1)</sup>	0-10.000	<b>T-6003L</b>	<b>T-6007L</b>	100	10	1.000	100
0-1400 <sup>1)</sup>	0-20.000	–	<b>T-6008L</b>	200	20	1.000	100
0-2800 <sup>2)</sup>	0-40.000	–	<b>T-6010L</b>	500	20	5.000	200
0-3500 <sup>2)</sup>	0-50.000	–	<b>T-6011L</b>	500	50	5.000	200

<sup>1)</sup> Accuracy ± 0,5%

<sup>2)</sup> Accuracy ± 1,5%

# Digital Hydraulic Pressure Gauges

▼ Shown: DGR-1



- **Two modes:** - Automatic shut off (15 min)  
- Continuous display
- **Zero reset** - ensures that gauge reads actual pressure
- **Maximum and minimum pressure displayed**
- **Peak On/Off mode** for 5000/second measuring mode
- **Rated for system pressure up to 1000 bar**
- **IP65 protection**
- **Displays high pressure in bar, psi and MPa; displays low pressure in kPa, MPa, hPa and mbar**
- **Display can be rotated 355 degrees** for easy reading and use in all positions
- **3 Volt battery included (type CR2430)** with 1400 hours continuous operation in standard mode.

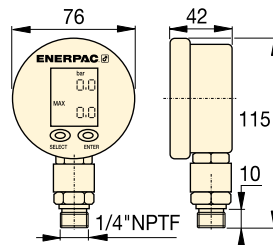

High Pressure Rating		High Pressure Rating		Model Number	Low Pressure Rating		Low Pressure Rating	
bar		MPa			kPa		mbar, hPa	
Range	Interval	Range	Interval		Range	Interval	Range	Interval
0-1000	0,2	0-100	0,02	<b>DGR-1</b>	0-20.000	200	0-20.000	200

High Pressure Rating: 0-15.000 psi, interval 3 psi.

Weight: 0,23 kg.

## DGR Series



Pressure Range:

**0 - 1000 bar**

Voltage:

**3 Volt (battery)**

Accuracy, % of full scale:

**± 0,2%**



### Gauge adaptor

For easy gauge installation into almost any system, Enerpac offers a complete line of gauge adaptors.

Page: 132

▼ *Greater accuracy and easier to read: enhance your ability to monitor and control hydraulic system pressure up to 1000 bar.*



▼ Shown from left to right: GA-3, V-91, GA-1, GA-2, GA-4, NV-251, GA-918







## GA, NV, V Series

Operating Pressure:  
**700 bar**

▼ A gauge is easily installed into your hydraulic system using a gauge adaptor.



**Gauge Adaptors (GA-Series)**

- For easy mounting of a pressure gauge onto your system
- Male end screws into pump or cylinder port, female end accepts hose or coupler, 3<sup>rd</sup> port is for gauge connection
- GA-918 provides for swivel connection

Model Number	Gauge Port (NPTF)	Male End (NPTF)	Female End (NPTF)	Dimensions (mm)					
				A	B	C	D	E	F
GA-1	1/2"	3/8"	3/8"	71	31	1/2" NPTF	3/8" NPTF	3/8" NPTF	32
GA-2	1/2"	3/8"		155	35	1/2" NPTF	3/8" NPTF	3/8" NPTF	32
GA-3	1/4"	3/8"		133	48	1/4" NPTF	3/8" NPTF	3/8" NPTF	32
GA-4	1/2"	1/4"		111	35	1/2" NPTF	1/4" NPTF	3/8" NPTF	32

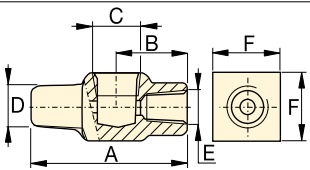

GA-1

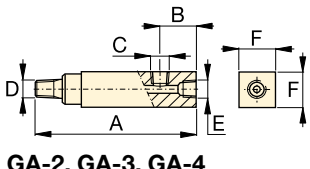

GA-2, GA-3, GA-4





**Swivel Adaptor (GA-918)**

- Simplifies gauge installation and reading

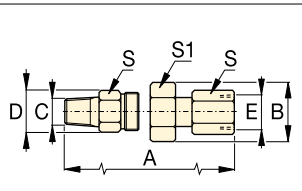
Model Number	Dimensions (mm)						
	A	B	C	D	E	S	S1
GA-918	117	43	1/2" NPTF	28,5	1/2" NPTF	29	38







**Needle Valves (V- and NV-Series)**

- Both NV-251 and V-91 provide positive shut-off
- 303 stainless steel stem, 16 threads/in (NV-251)

Model Number	Orifice (mm)	Thread Size	Dimensions (mm)						
			A	B	C	D	E	F	H
NV-251	4,3	1/4" NPTF	57	29	1/4" NPTF	57	46	19	19
V-91	4,8	1/2" NPTF	89	32	1/2" NPTF	64	32	37	37

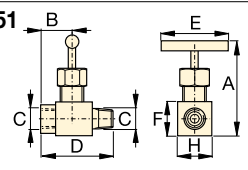
NV-251



V-91

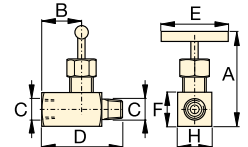



# Enerpac Application Ideas

By using only Enerpac branded oil and couplers, you are protecting the integrity of your system with components that are designed to work with your Enerpac rams, cylinders, pumps and tools. Protect your investment and personnel, demand only Enerpac accessories.



## ▲ H700-Series Hydraulic Hoses

Enerpac H700-Series hydraulic hoses are designed to provide the best performance of your Enerpac products. Available in thermoplastic construction, a number of lengths and internal diameters, and with a number of end-configurations, there will be an Enerpac hose to perfectly match your exact application.

## C-Series Couplers ▲

Enerpac C-Series couplers provide easy hose and tool connectivity while providing correct performance and pressure ratings to operate most Enerpac products.

## G-Series Gauges ►

Enerpac gauges and gauge adaptors make monitoring your systems performance easy while minimizing the risk of overloading and ensuring long, dependable service. Gauges are available to read pressure or force in kN or ton for many Enerpac cylinders.





▼ From left to right: V-152, V-66, V-82, V-161, V-42, V-17



## Your Hydraulic Control Solution



### Valve Applications

To see these valves used in typical hydraulic circuits, please see our 'Yellow Pages'.

Page: **244**

▼ The V-152 pressure relief valve limits the pressure or force developed in the hydraulic system.



- All valves are rated for 700 bar operating pressure
- All valves feature NPTF porting to insure against leakage at rated pressure
- All valves are painted, coated, or plated for corrosion resistance
- Viton® seals (in V-66NV and V-152NV) for high temperature applications, nickel-plated for maximum corrosion resistance.

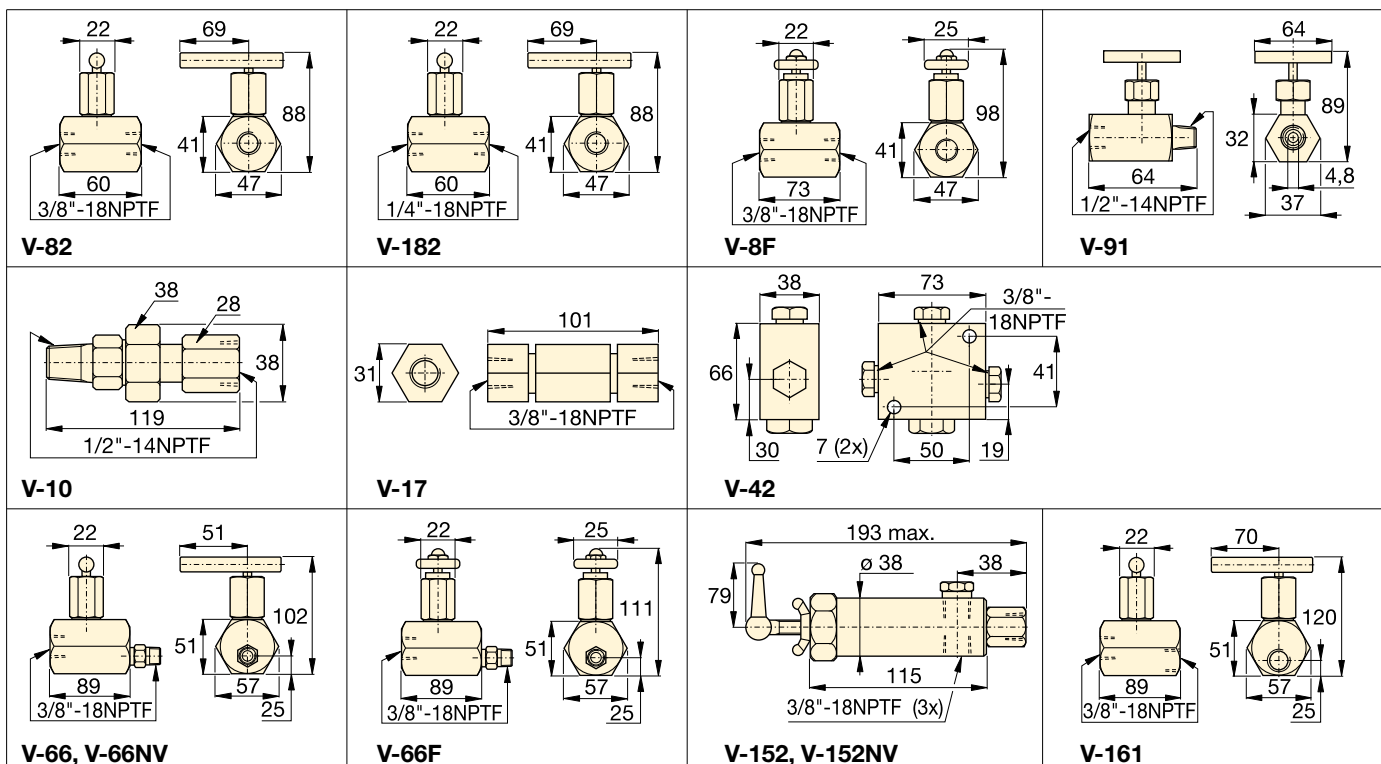

Valve dimensions in mm

# Pressure and Flow Control Valves



## Control Manifolds

For two or four port manifolds with integral flow control valves, see the manifold page of the System Components section.

Page: 124



## Fittings











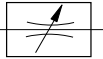

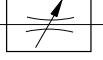

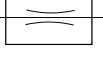
For additional fittings see the fitting page of the System Components section in this catalogue.

Page: 125

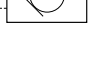
## V Series

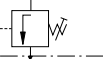

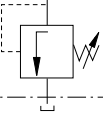
Maximum Operating Pressure:  
**700 bar**

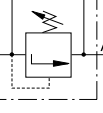
Valve Type and Model Number	Description	Hydraulic Symbol
<b>Needle Valve</b> <b>V-82</b> <b>V-182</b> <b>V-8F</b>	 <p><b>V-82:</b> To control cylinder speed. Can also be used as shut-off valve for temporary load holding. ¼" NPTF female ports. Also suitable for gauge snubbing (also V-82).  <b>V-8F:</b> Like V-82, but with very fine metering for precise flow control.  <b>V-182:</b> Same as V-82, but with ⅜" NPTF female ports.  <b>Not recommended as shut-off valve.</b></p>	
<b>Snubber Valve</b> <b>V-91</b>	 <p><b>V-91:</b> Infinitely adjustable for metering oil out of a gauge to protect the gauge during high cycling applications. ½" NPTF male and female threads for use with GA-1, GA-2 or GA-4 gauge adaptors. Also suitable as shut-off valve to protect the gauge during high cycling applications.</p>	
<b>Auto Damper® Valve</b> <b>V-10</b>	 <p><b>V-10:</b> To be used when gauge pressure must be monitored during high cycle applications. Creates a flow resistance when load is released suddenly. No adjustments are necessary. ½" NPTF male and female threads for use with GA-1, GA-2 or GA-4 gauge adaptors.</p>	
<b>Check Valve</b> <b>V-17</b>	 <p><b>V-17:</b> Ruggedly built to resist shock and operate with low pressure drop. Closes smoothly without pounding. ⅜" NPTF female port.</p>	
<b>Pilot Operated Check Valve</b> <b>V-42</b>	 <p><b>V-42:</b> Can be mounted at the cylinder to hold the load in case of system pressure loss. Normally used with double-acting cylinders where pilot port receives pressure from a Tee-fitting in the cylinder retract line. ⅜" NPTF female ports. Pilot pressure ratio 14% (6,5:1).</p>	
<b>Manually Operated Check Valve</b> <b>V-66, V-66NV *</b> <b>V-66F</b>	 <p><b>V-66, V-66NV:</b> For load holding applications with single and double acting cylinders. Valves allow oil to flow back to tank when cylinder retracts. V-66NV with Viton seals, nickel-plated.  <b>V-66F:</b> Similar to V-66, but with very fine metering capability for precise flow control. V-66F is not designed for load holding.</p>	
<b>Pressure Relief Valve</b> <b>V-152</b> <b>V-152NV *</b>	 <p><b>V-152:</b> Limits pressure developed by the pump in hydraulic circuit, thus limiting the force imposed on other components. Valve opens whenever preset pressure is reached. To increase pressure setting, turn handle clockwise. Includes:          • 0,9 m return line hose kit,          • ± 3% repeatability,          • 55-700 bar adjustment range.</p>	
<b>Sequence Valve</b> <b>V-161</b>	 <p><b>V-161:</b> To control oil flow to a secondary circuit. Flow is blocked until system pressure rises to the V-161 setting. When this pressure level is reached, the V-161 opens to allow flow to the secondary circuit. A pressure differential is always maintained between the primary and secondary circuit.  <b>Min. operating pressure: 140 bar.</b></p>	

\* See page 60 for more information about products for use in high temperature and extreme environment applications.

# Enerpac Hydraulic Presses

ENERPAC Hydraulic Presses are available in a variety of capacities and sizes. The press frames are designed for maximum strength and durability. Strong frames and powerful high-pressure hydraulics will provide years of dependable service in many applications.

ENERPAC Presses are available in Bench, C-Frame, Arbor, Workshop and Roll-Frame models.

These Press features increase productivity and broaden the range of applications:

#### Side-to-side cylinder movement

Lateral movement capability of cylinder in upper bed.



#### Press Kits

The 50 and 75 ton XLP-Series presses come as unassembled kits, and include complete press frame, winch, cylinder, pump with gauge, couplers and hose.











#### Winch

Movable upper and lower bed with self-braking winch on XLP-Series presses.





# Press Section Overview

Capacity ton (kN)	Press type and functions	Serie		Page
10 (101)	<b>Bench Presses</b>	VLP		138 ▶
25-200 (232-1995)	<b>Workshop Presses</b>	XLP VLP		138 ▶
50-200 (498-1995)	<b>Roll-Frame Presses</b>	BPR		140 ▶
5-20 (45-178)	<b>C-Clamp Presses</b>	A		142 ▶
10-30 (101-295)	<b>Arbor Presses</b>	A		142 ▶
5 (44,5)	<b>Hydraulic Bench Vise</b>	BV		144 ▶
10-200 (101-1995)	<b>Press Accessories</b> <b>Press Application Idea</b>	VB, A, IPL		146 ▶
900-90.000 kg	<b>Tension Meters</b> <b>Load Cells</b>	TM LH		147 ▶

Available in capacities from 10 to 200 ton, each Enerpac press consists of three basic high quality components: a press frame, a power source and a cylinder.

## Press Frame

Press frames include features like workpiece side-loading and height adjustment of the upper and lower bed.

## Power Source

Depending on the production requirements, Enerpac presses can be powered by manual, air-hydraulic and electric-drive power sources.

## Cylinder

Depending on the application, double-acting cylinders offer increased efficiency. Check out the Selection Charts for the press best suited for your needs.

## Gauge

All Workshop presses and Roll-Frame Presses feature an easy to monitor pressure/force gauge for increased safety.



### IMPORTANT!

**The frameworks of the workshop presses are exclusively designed for pressing operations, not for pulling. For pulling applications please contact Enerpac.**

In order to fully comply with CE regulations, some presses must be equipped with specific safety components, such as spring centered valves, two-hand control devices, guards or others.

Enerpac standard general purpose presses are supplied without guards, and have a plunger speed of less than 10 mm/second. However, your application may require that measures should be taken to reduce the risk of injury to operators and other personnel by providing appropriate safeguarding, training and conducting a risk assessment, which eliminates or reduces danger.

Health & safety within your workplace is your responsibility, not that of Enerpac.

Advice on such matters is available from your local enforcement agency. If you require any further information on Enerpac accessories that may help you conform to the Machinery Directive or European legislation contact Enerpac.





# Bench and Workshop Presses

▼ From left to right: XLP-506XA12G, XLP-256XA11G



## No Workshop can do without one



### XA-Series Foot Pump

The XLP-press with XA-Series air powered foot pump:

- no need to fully lift up foot
- rest bodyweight on heel, resulting in a handsfree and stable working position
- safe and controlled press operation (see page 100 for XA-Series Pumps).



### Press Kits \*

The 50 and 75 ton presses come standard as unassembled kits, and include complete press

frame, winch, cylinder, pump with gauge, couplers and hose.



### Easy grip forklift access

Cut-away in lower frame for pallet truck access allows easy transportation of 50 and 75 ton XLP-series presses.



### Side-to-side cylinder movement



Cylinder can be positioned horizontally side-to-side on all XLP-Series presses.

- All presses equipped with long life Golden Ring Design cylinder
- XLP-Series presses**
- Multi-functional presses in kit form (50 and 75 ton presses)
- Easy grip forklift access on 50 and 75 ton presses
- Height adjustment of upper or lower bed with winch (50 & 75 ton)
- Width adjustment allows cylinder to move from side-to-side
- Pump options include XA-Series air-operated foot pump
  - pressure gauge integrated in pump for optimal control
  - suitable for delicate pressing jobs from variable oil flow.

### VLP-Series presses

- Unique “Hydrajust” bed positioning device on 100 and 200 ton VLP-presses allows adjustment of the lower bed.

### ▼ SELECTION CHART

Press Capacity ton (kN)	Maximum Daylight (mm)		Press Model Number	Power Source						Cylinder					
	Vertical	Horizontal		Pump Type			Valve Type		Pump Model Nr.	Page:			Stroke (mm)	Cylinder Model Nr.	Page:
				Man.	Elec.	Air	Man.	Elec.							
10 (101)	430	432	VLP-106P142	●			●		P-142	66	●		156	RC-106	6
	430	432	VLP-106PAT1			●	●		PATG-1102N	102	●		156	RC-106	6
25 (232)	1225	510	XLP-256P392	●			●		P-392	66	●		158	RC-256	6
	1225	510	XLP-256XA11G			●	●		XA-11G	100	●		158	RC-256	6
50 (498)	993	990	XLP-506P802 *	●			●		P-802	68	●		159	RC-506	6
	993	990	XLP-506XA12G *			●	●		XA-12G	100	●		159	RC-506	6
	993	990	XLP-506ZES *		●			●	ZE4410SE-E050	92		●	156	RR-506	32
	993	990	XLP-5013ZES *		●			●	ZE4410SE-E050	92		●	334	RR-5013	32
75 (718)	989	990	XLP-756XA12G *			●	●		XA-12G	100	●		156	RC-756	32
100 (933)	989	990	VLP-1006ZES		●			●	ZE5420SW-E050	92		●	168	RR-1006	32
	989	990	VLP-10013ZES		●			●	ZE5420SW-E050	92		●	333	RR-10013	32
200 (1995)	1340	1220	VLP-20013ZES		●			●	ZE6420SW	92		●	330	RR-20013	32

\* 50 and 75 ton XLP-Series presses can be ordered as factory assembled press frame. Add suffix “M” to press model number. Example: XLP-506XA12G-M.



= Single-Acting



= Double-Acting

# Bench and Workshop Presses



## Optional V-Blocks

To facilitate positioning of pipes and bars, or placed upside-down, to serve as a convenient worktable.

Featuring precise fit into the press bolster. Each model number includes two V-blocks.

To be used with press (ton)	V-Blocks Model Number
10	VB-10
25	VB-25
50	VB-501
75, 100	VB-101
200	A-200

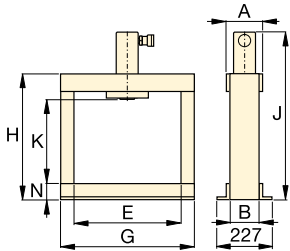

VLP 10 ton

## "Hydrajust" Bed Positioning

Allows vertical adjustment of the lower bed on 100 and 200 ton VLP presses.

**IMPORTANT:** The "Hydrajust" bed positioning is not designed to withstand full cylinder capacity, only to be used for bed adjustment.

Page: 146

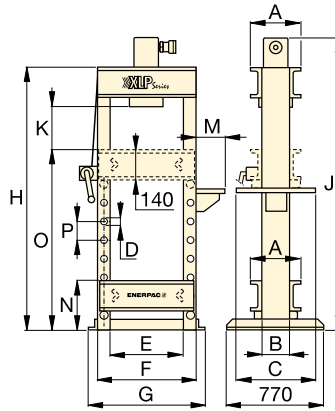

XLP 25 ton

## XLP, VLP Series



Capacity:

**10 - 200 ton**

Maximum Daylight x Width:

**1340 x 1220 mm**

Maximum Operating Pressure:

**700 bar**



### IMPORTANT!

The frameworks of the workshop presses are exclusively designed for pressing operations, not for pulling. For pulling applications please contact Enerpac.

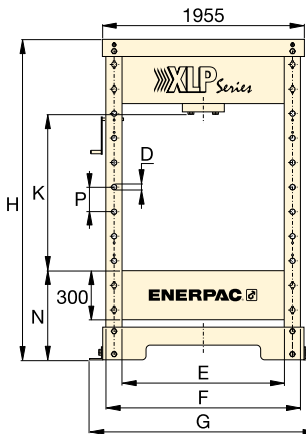

XLP 50 and 75 ton

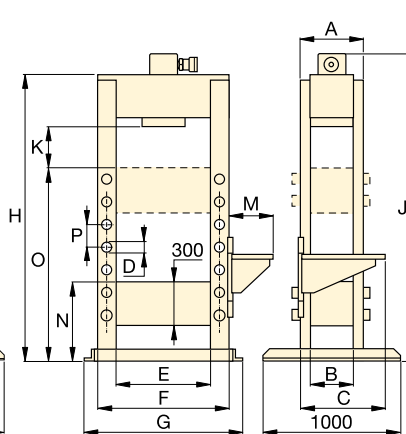

VLP 100 ton

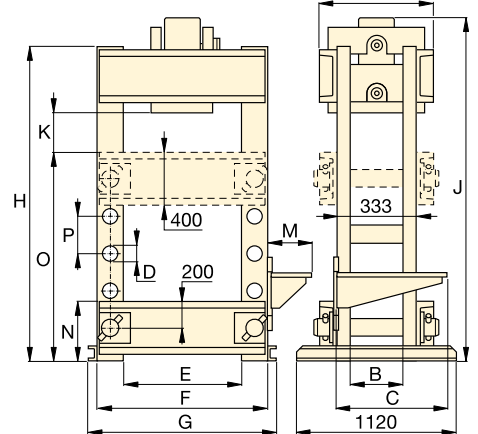

VLP 200 ton

Speed (mm/s) **		Dimensions (mm)															Press Model Number
Rapid Advance	Pressing	A	B	C	D	E	F	G	H	J	K	M	N	O	P	(kg)	
{2,5} **	{0,6} **	110	80	-	-	432	-	542	620	748	430	-	80	-	-	49	<b>VLP-106P142</b>
10,0	1,8	110	80	-	-	432	-	542	620	748	430	-	80	-	-	54	<b>VLP-106PAT1</b>
{3,4} **	{0,7} **	260	140	510	32	510	630	700	1622	1740	370	140	212	1070	122	165	<b>XLP-256P392</b>
10,0	1,3	260	140	610	32	510	630	700	1622	1740	370	323	212	1070	122	170	<b>XLP-256XA11G</b>
{5,5} **	{0,3} **	310	240	-	32	990	1190	1390	1995	-	210-940	-	540	-	150	595	<b>XLP-506P802 *</b>
4,7	0,6	310	240	-	32	990	1190	1390	1995	-	210-940	-	540	-	150	600	<b>XLP-506XA12G *</b>
10,0	2,0	310	240	-	32	990	1190	1390	1995	-	210-940	-	540	-	150	660	<b>XLP-506ZES *</b>
10,0	2,0	310	240	-	32	990	1190	1390	1995	-	210-940	-	540	-	150	700	<b>XLP-5013ZES *</b>
3,2	0,4	420	330	-	40	990	1240	1430	1995	-	210-940	-	540	-	150	900	<b>XLP-756XA12G *</b>
10,0	2,1	400	340	560	40	990	1240	1400	1879	1885	239	425	540	1290	150	970	<b>VLP-1006ZES</b>
10,0	2,1	400	340	560	40	990	1240	1400	1879	2050	239	425	540	1290	150	993	<b>VLP-10013ZES</b>
6,6	1,6	553	233	560	76	1220	1620	1740	2285	2370	377	425	453	1415	254	1992	<b>VLP-20013ZES</b>

\*\* {...} = advance speed in mm per handpump stroke.

▼ Shown: **BPR-5075**



- **Quality welded frame for maximum strength and long life**
- **Frame rolls easily on 4 steel roller bearings**
- **Exclusive 'Hydra-Lift' bolster for effortless adjustment of the vertical daylight**
- **Roller head design is standard to allow lateral movement and locking of the cylinder up to 300 mm left or right of centre**
- **All models in the quick selection chart have been matched to an electric pump, double-acting cylinder, hose and gauge, offering the complete package**
- **Roll-Frame design features a stationary bed with the ability to support heavy loads.**

## Expert Designed Versatility



### Cylinder adjustment

Cylinder adjustment allows horizontal side to side cylinder positioning.



### Hydra-Lift

Allows easy, effortless daylight adjustment. Standard on all Roll-Frame presses.

Page: **146**



### Optional V-Blocks

These V-Blocks are designed for easy fixturing of round stock and other non-uniform materials. Featuring precise fit into the press bolster.

Page: **146**

### ▼ SELECTION CHART

Press Capacity ton (kN)	Vertical Daylight A (mm)		Maximum Bed Width E (mm)	Electric Pump		Press Model Number	Double-Acting Cylinder			Speed (mm/sec)	
	min.	max.		Model Number	Page		Stroke (mm)	Model Number	Page	Rapid Advance	Pressing
<b>50 (498)</b>	152	942	730	ZE5420SW-S	92	<b>BPR-5075</b>	334	RR-5013	32	4,1	3,9
<b>100 (933)</b>	159	1048	889	ZE3420SW	92	<b>BPR-10075</b>	333	RR-10013	32	7,7	0,7
<b>200 (1995)</b>	279	1295	1219	ZE4420SW	92	<b>BPR-20075</b>	330	RR-20013	32	5,2	0,5

# Roll-Frame Presses



▲ A BPR-20075 Roll-Frame Press is used to remove a large shaft from this pillow-block assembly. The Roll Frame design allows this heavy part to be safely loaded with an overhead crane.

## BPR Series



Capacity:  
**50 - 200 ton**

Maximum Daylight x Width:  
**1295 x 1219 mm**

Maximum Operating Pressure:  
**700 bar**



### IMPORTANT!

The frameworks of the presses are exclusively designed for pressing operations, not for pulling. For pulling applications please contact Enerpac.

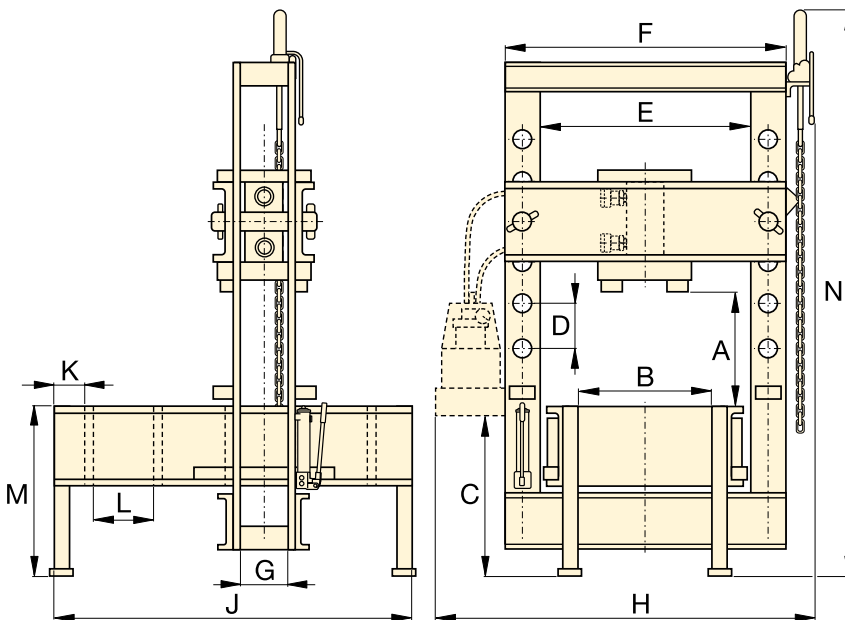

### Gauges

All press models include a gauge and gauge adaptor, matching the press capacity:

Press Capacity	Gauge Model Number	Adaptor Model Number
ton		
50	GF-50B	GA-2
100	GF-871B	GA-3
200	GF-200B	GA-3

For more information on gauges, please refer to the System Components section.

Page: 126

Roll-Frame Press Dimensions (mm)													Press Model Number	
A (min.-max.)	B	C	D	E	F	G	H	J	K	L	M	N		(kg)
152-942	526	971	264	730	933	127	1420	1626	203	270	762	2870	917	BPR-5075
159-1048	673	965	222	889	1143	146	1605	1676	203	270	813	3021	1767	BPR-10075
279-1295	984	933	254	1219	1626	232	2150	2197	203	381	915	3200	4186	BPR-20075



▼ Shown from left to right: A-220, A-330 and A-310



## The Standard Workshop Tools



### Push Pin A-183

For applications requiring precision pressing, such as shaft removal and insertion. This attachment fits 10 ton cylinders and requires the use of a threaded adaptor saddle (A-13).

Page: 166



### Smooth Saddle A-185

For pressing applications of delicate parts, such as aluminium castings, this saddle decreases surface marks during the pressing application. Requires 10 ton cylinder and threaded adaptor saddle (A-13).

Page: 167



### 10 ton Bench Presses

For 10 ton VLP-Series Bench Presses selection see:

Page: 138

### C-Clamp Press

- 5, 10 and 20 ton capacity
- Operational in all positions.

### Arbor Press

- 10 and 30 ton capacity
- Foot mounting holes for horizontal or vertical positioning
- Machined working surfaces for easier fixturing
- Slotted back to simplify loading and unloading of longer parts.

▼ A-310 Arbor Press used for compacting powder at 10 ton.



### ▼ SELECTION CHART

Press Type	Press Capacity ton (kN)	Maximum Vertical Daylight (mm)	Maximum Bed Width (mm)	Press Model Number	Cylinder Model Number *	Page:
C-Clamp	5 (45)	165	51	A-205	5 ton RC-cylinder*	6
	10 (101)	228	57	A-210	10 ton RC-cylinder*	6
	20 (178)	305	70	A-220	25 ton RC-cylinder**	6
Arbor	10 (101)	227	135	A-310	10 ton RC-cylinder*	6
	30 (295)	260	178	A-330	RC-308*	6

\* Recommended cylinder must be ordered separately.

\*\* Must be limited to 20 ton.

# C-Clamp and Arbor Presses



▲ A perfect example of the force and versatility of the Enerpac A-220 C-Clamp press.

## A Series



Capacity:  
**5 - 30 ton**

Maximum Daylight x Width:  
**305 x 178 mm**

Maximum Operating Pressure:  
**700 bar**



### IMPORTANT!

For high-cycle production applications, the C-Clamp and Arbor presses should be limited to 50% of their capacity.

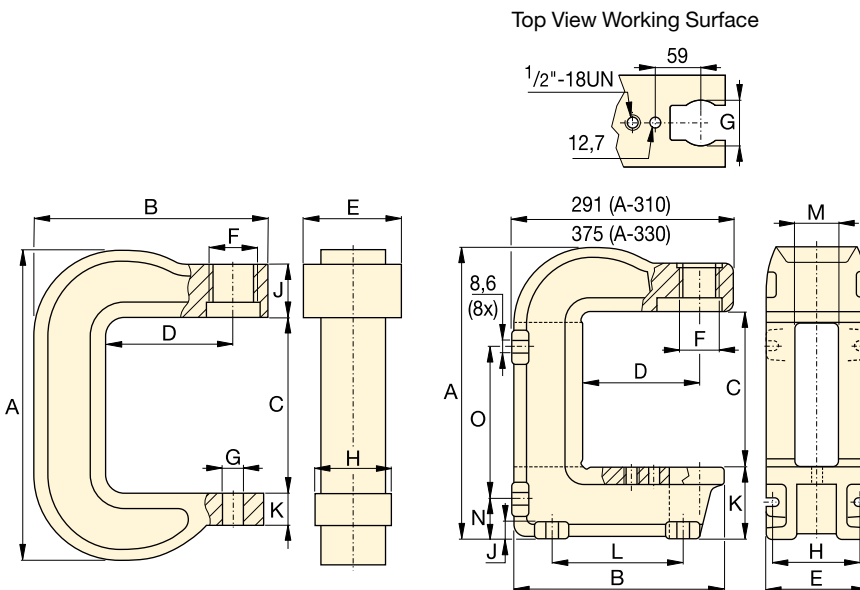

A-205, A-210, A-220

A-310, A-330



### Hydraulic Cylinders

Cylinders for C-Clamps and Arbor Presses must be ordered separately.

Page: 5



### Hydraulic Pumps

Pumps for C-Clamps and Arbor Presses must be ordered separately.

Page: 65

Press Dimensions (mm)															Press Model Number
A	B	C	D	E	F	G	H	J	K	L	M	N	O		
291	203	165	95	73	1½" -16 UN	26	51	66	25	-	-	-	-	7	A-205
406	283	228	152	83	2¼" -14 UN	26	76	64	41	-	-	-	-	17	A-210
540	346	305	152	108	3 <sup>5</sup> / <sub>16</sub> " -12 UN	26	95	70	44	-	-	-	-	38	A-220
414	281	227	152	135	2¼" -14 UN	63	122	19	97	175	65	54	219	27	A-310
557	353	260	152	178	3 <sup>5</sup> / <sub>16</sub> " -12 UN	63	140	25	165	203	67	98	276	86	A-330

# BV-Series, Hydraulic Bench Vise

▼ Shown: **BV-5 Hydraulic Bench Vise**



- 44,5 kN of force for forming and pressing applications
- 203 mm jaws hold large objects, making cumbersome tasks into one-person jobs
- Hands-free operation for safe and controlled actuation when paired with PA-133 air-powered foot pump
- Flexible-use and ergonomically-friendly tool mounts as a press vertically or as a bench vise horizontally with a swivel base
- Rapid spring return makes repetitive work faster
- Accessory Magnetic Jaw Liners free hands by holding sockets, screws, rings, c-clips, springs, etc.



◀ *Enerpac BV-5 Hydraulic Bench Vise mounted vertically for high-force pressing applications*

*Enerpac BV-5 Hydraulic Bench Vise with hands-free PA-133 Foot Pump makes work with a large heavy piece into a one person job.*

## Safe, controlled, hands-free clamping



### Hydraulic Bench Vise Sets

Order everything needed in one box to start working. The BV-5 Hydraulic Bench Vise is available as a set (pump, coupler and vise with hose).

Set Model Number	Vise Model Number	Pump Model Number	Coupler Model Number
<b>STV-5A</b>	BV-5 *	PA-133	CR-400

\* Includes hose HC-7206.

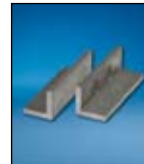

### Magnetic Jaw Liners

Don't forget to order **BV-5VC** Magnetic Jaw Liners. The magnet inserts hold steel objects like sockets, screws and rings. Accessories must be ordered separately

Model Number

**BV-5VC**



# Hydraulic Bench Vice



## Hydraulic Bench Vice

The Hydraulic Bench Vice is a general purpose tool that can have multiple clamping and holding applications. Its hydraulic cylinder applies force of up to 5 ton, three-to-five times the force of a manually operated vise. Hydraulic pressure closes the vise, and spring-return opens the jaws.

The Hydraulic Bench Vice can be installed horizontally on a flat surface, vertically as a press, or in any other orientation that satisfies the safety criteria stipulated by the operators' manual.

## BV Series



Maximum Force:

**44,5 kN**

Maximum Jaw Opening:

**203 mm**

Jaw Width:

**203 mm**

Maximum Operating Pressure:

**700 bar**

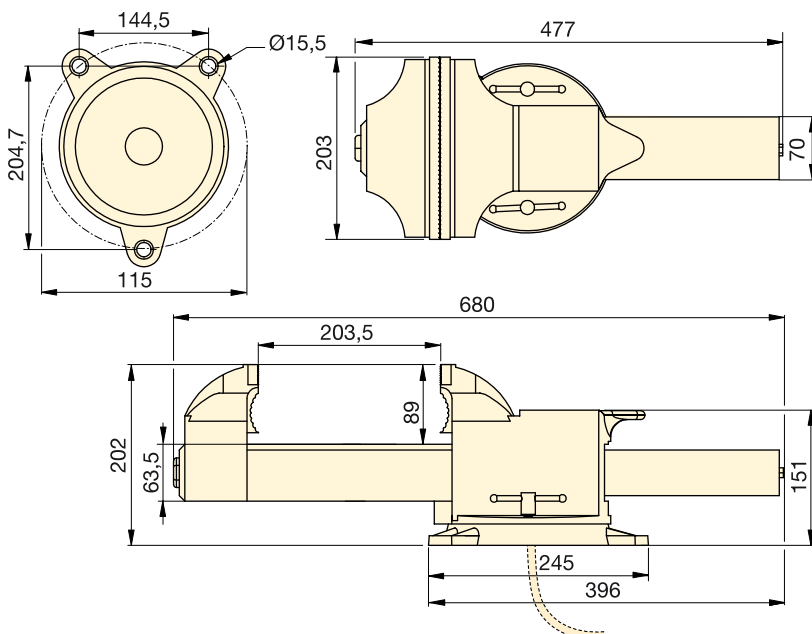



▼ Enerpac BV-5 Hydraulic Bench Vice with hands-free PA-133 Foot Pump for safe and controlled actuation.



## ▼ SELECTION CHART

Maximum Force at 700 bar	Model Number	Oil Capacity	Height	Jaw Width	Jaw Opening (Fully Open)	Length (Jaws Closed)	Length (Jaws Open)	Weight (Vise only)
ton (kN)		(cm <sup>3</sup> )	(mm)	(mm)	(mm)	(mm)	(mm)	(kg)
5 (44,5)	<b>BV-5</b>	131	202	203	203	477	680	25



Description	Press Capacity and Press Series	Model Number		Features
<b>V-Blocks</b>	10 ton Bench VLP-Presses 25 ton Workshop XLP-Presses 50-75 ton Workshop XLP-Presses 100 ton Workshop VLP-Presses 200 ton Workshop VLP-Press 200 ton BPR-Roll-Frame Press	<b>VB-10</b> <b>VB-25</b> <b>VB-501</b> <b>VB-101</b> <b>A-200</b> <b>A-200R</b>		<ul style="list-style-type: none"> <li>Facilitate positioning of pipes and bars</li> <li>All V-Block model numbers include 2 V-blocks.</li> </ul>
<b>Hydra-Lift</b>	50 ton BPR-Roll-Frame Press 100 ton BPR-Roll-Frame Press 200 ton BPR-Roll-Frame Press	<b>IPL-R100</b> <b>IPL-R100</b> <b>IPL-R200</b>		<ul style="list-style-type: none"> <li>Allows easy, effortless daylight adjustments</li> <li>Includes accessory chain.</li> </ul>
<b>Hydrajust Bed Positioning</b>	100 ton Workshop VLP-Presses 200 ton Workshop VLP-Press  <b>IMPORTANT!</b> The “Hydrajust” bed positioning is not designed to withstand full cylinder capacity, only to be used for bed adjustment.	<b>VHJ-100</b> <b>BSS-5380</b>		<ul style="list-style-type: none"> <li>Allowing effortless daylight adjustment by moving the lower bed up and down</li> <li>Can be used with presses equipped with double-acting cylinder.</li> </ul>

## ▼ PRESS APPLICATION IDEAS



### ◀ 600 Ton High-Accuracy Collar Press

For production of accelerator coils, sheet metal needs to be formed into a specific shape and size. The end product of this forming is a cylindrical collar, which has a very solid structure, specific shape, and a tight tolerance for circularity and concentricity.

The Enerpac team was consulted to accomplish this task using proven high-pressure technology. The 600-ton press consisted of two separate hydraulic systems. The first system featured eight 25-ton cylinders, to position the sheets, while the second system featured eight 75-ton cylinders, to press the sheets into the correct shape. The results were a hydraulic press system that increased productivity and lowered operating costs.

### Fully Automated PLC-Controlled 1800 Ton High-Accuracy Press ▶

The pressing and heating cycle, during the production of magnetic acceleration coils, required high force and high-accuracy to ensure absolute quality.

Enerpac was consulted to assist in the design of a high accuracy production press. Control of the press force is monitored along with the temperature of the coils during forming by a PLC Control System.



# Tension Meter and Load Cells

▼ Shown: LH-102 and TM-5 (in middle)



## TM LH Series



Capacity:

**900 - 90.000 kg**

Accuracy, % of full scale:

**± 2%**



TM and LH models are 100% tested to verify accuracy within a ± 2% range.

If your application requires a calibrated tool, it must be submitted for certification testing. Certification is NOT available from Enerpac.

### Tension Meter TM-5

- Accuracy ± 2% of full scale
- Zinc and bronze plated to resist corrosion
- Dual-range readout in kilograms and pounds
- Maximum indicating pointer reading for pre-selected forces or to maintain force readings
- Cushioned metal case provides safe storage and transport.

### Load Cells LH-Series

- Accuracy ± 2% of full scale
- Swivel loading pad reduces eccentric loading for improved accuracy
- Maximum indicating pointer reading pre-selected forces or to maintain maximum force readings
- Dual-range readout in kilograms and pounds.

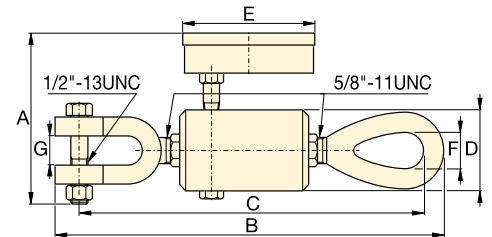

TM-5

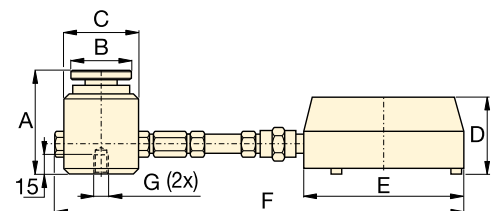

LH-Series

Type	Gauge Capacity		Model Number	Minimum Reading		Gauge Increments		Dimensions (mm)						
	(kg)	(lbs)		(kg)	(lbs)	(kg)	(lbs)	A	B	C	D	E	F	G
Direct Mounted	4.500	10.000	TM-5	500	1.000	100	100	120	247	236	50	93	22	19
Direct Mounted Load Cell	900	2.000	LH-10	100	200	20	20	77	44	57	60	101	215	1/4" - 20, 44,5 BC
	4.500	10.000	LH-50	500	1.000	100	100	77	44	57	60	101	215	1/4" - 20, 44,5 BC
Remote Mounted with 0,6 m Hose	900	2.000	LH-102	100	200	20	20	77	44	57	60	147	846	1/4" - 20, 44,5 BC
	4.500	10.000	LH-502	500	1.000	100	100	77	44	57	60	147	846	1/4" - 20, 44,5 BC
	9.000	20.000	LH-1002	1.000	2.000	200	200	77	44	57	60	147	846	1/4" - 20, 44,5 BC
Remote Mounted with 1,8 m Hose	21.000	50.000	LH-2506	3.000	5.000	500	500	101	69	85	60	147	2094	3/8" - 24, 63 BC
	45.000	100.000	LH-5006	5.000	5.000	1.000	1.000	132	101	127	60	147	2135	3/8" - 24, 89 BC
	90.000	200.000	LH-10006	10.000	10.000	1.000	2.500	158	127	158	60	147	2166	3/8" - 24, 102 BC

BC = Bolt Circle

# Hydraulic and Mechanical Pullers

ENERPAC offers a complete line of pullers with the widest range of sizes, capacities and styles. Whether your application requires mechanical, hydraulic or the patented Posi Lock® system, Enerpac can satisfy your requirements.

Made of high strength steel alloys, you can depend on Enerpac pullers to provide years of trouble-free operation, even in the harshest environments.



## Hydraulic Pullers

These hydraulic pullers eliminate time-consuming and unsafe hammering, heating or prying. Damage to parts is minimized through the use of controlled hydraulic power.



## Posi Lock® Pullers

The puller that meets the safety challenge. A control cage holds the pulling jaws securely in working position. This patented feature reduces the possibility of the puller jaws slipping off the work surface, thereby increasing productivity and tool life and reducing dangerous situations for the user. The Posi Lock® feature is available in a mechanical or hydraulic version.



**WARNING**  
Do not exceed 50% of the rated puller capacity when using a double crosshead (2 grip arms) or when using puller legs in combination with bearing puller attachment.



**CAUTION!**  
Not all puller components and configurations are rated at the set capacity. Please contact Enerpac for details.



Always wear Safety Goggles while using pullers.

# Puller Section Overview

When selecting a puller it is important to consider 3 basic specifications:

## 1. The Capacity:

is the amount of force the puller is capable of producing.

Typically, the capacity required for a job can be determined by using the shaft diameter of the part being pulled.

For manual pullers, the center bolt diameter of the puller should be at least half the diameter of the shaft being pulled from.

For hydraulic pullers, the capacity in tons should be 0,28 to 0,4 times the shaft diameter in mm. Use the following chart:











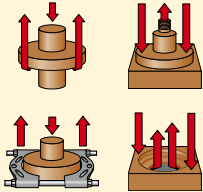

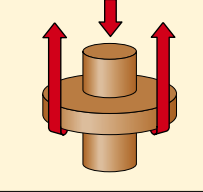

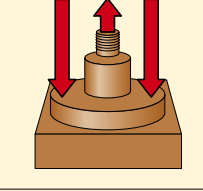

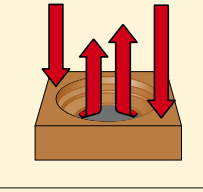
Shaft Diameter	Puller Capacity
0 - 25 mm	10 ton
25 - 50 mm	20 ton
50 - 89 mm	30 ton
89 - 140 mm	50 ton

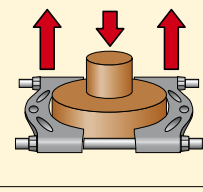
## 2. The Reach:

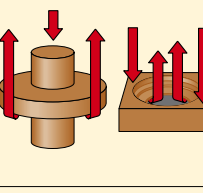
is the distance between the bottom of the base and the jaw flats. The puller's reach must equal or exceed the same distance of the part being pulled.

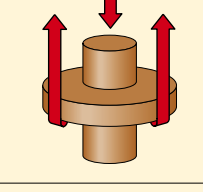
## 3. The Spread:

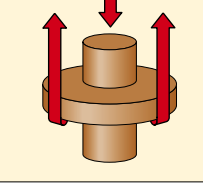
is the distance between the jaws. The puller's spread needs to be greater than the width of the part being pulled.

Puller Function	Capacity ton	Puller Type	Series	Page
	8-50	<b>Master Puller Sets</b> Max. Reach: 252 - 700 mm Max. Spread: 250 - 1100 mm	<b>BHP</b>	 <b>150</b> ▶
	8-50	<b>Grip Puller Sets</b> Max. Reach: 249 - 700 mm Max. Spread: 50 - 580 mm	<b>BHP</b>	 <b>151</b> ▶
	8-50	<b>Cross Bearing Puller Sets</b> Max. Reach: 354 - 863 mm Max. Spread: 266 - 570 mm	<b>BHP</b>	 <b>152</b> ▶
	8-50	<b>Bearing Cup Pullers</b> Max. Reach: 110 - 145 mm Max. Spread: 26 - 359 mm	<b>BHP</b>	 <b>153</b> ▶
	8-50	<b>Bearing Pullers</b> Max. Width: 110 - 264 mm Max. Spread: 10 - 245 mm	<b>BHP</b>	 <b>153</b> ▶
	2-40	<b>Posi Lock® Mechanical Pullers</b> Max. Reach: 101 - 355 mm Max. Spread: 12 - 635 mm	<b>EP EPP EPX EPPMI</b>	 <b>154</b> ▶
	10-50	<b>Posi Lock® Hydraulic Pullers</b> Max. Reach: 203 - 355 mm Max. Spread: 304 - 635 mm	<b>EPH EPHR EPHS</b>	 <b>158</b> ▶
	100	<b>Posi Lock® Hydraulic Pullers</b> Max. Reach: 1219 mm Max. Spread: 190 - 1778 mm	<b>EPH</b>	 <b>161</b> ▶



▼ Shown: Master Puller Set BHP-3751G



## Multi Purpose Puller Set



**WARNING**

Do not exceed 50% of the rated puller capacity when using a double crosshead (2 grip arms) or when using puller legs in combination with bearing puller attachment.

- Supplied with a full hydraulic set including pump, hose, cylinder, gauge, gauge adaptor and wooden case
- High quality, forged steel components provide superior reliability and service
- Sets include speed crank and adjusting screw for fast contact to work before hydraulics are applied
- All Master Puller Sets include a Grip Puller, a Cross Bearing Puller, a Bearing Cup Puller and a Bearing Puller Attachment, which can be ordered separately, see items nr. 10, 20, 30 and 40.

▼ Maintenance engineers throughout the industry greatly appreciate the Enerpac Master Puller sets

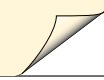

▼ SELECTION CHART

Master Puller Set Capacity *	8 ton	20 ton	30 ton	50 ton	Page:
Model Number ►	BHP-1752 <sup>1)</sup>	BHP-2751G	BHP-3751G	BHP-5751G	
Included Hydraulics Set Weight ►	37 kg	90 kg	172 kg	298 kg	
• Hand Pump	P-142	P-392	P-392	P-80	66-69 ►
• Cylinder	RWH-121	RCH-202	RCH-302	RCH-603	26 ►
• Saddle	–	HP-2015	HP-3015	HP-5016	27 ►
• Hose	HB-7206QB	HC-7206	HC-7206	HC-7206	120 ►
• Gauge	GF-120B	GF-813B	GF-813B	GF-813B	126 ►
• Gauge Adaptor	GA-4	GA-3	GA-3	GA-3	132 ►
<b>Included Pullers</b>					
<b>10</b> Grip Puller	BHP-1762	BHP-252	BHP-352	BHP-552	151 ►
<b>20</b> Cross Bearing Puller	BHP-1772	BHP-262	BHP-362	BHP-562	152 ►
<b>30</b> Bearing Cup Puller	BHP-180	BHP-280	BHP-380	BHP-580	153 ►
<b>40</b> Bearing Puller	BHP-181	BHP-282	BHP-382	BHP-582	153 ►
• Case	CM-6	CW-350	CW-350	CW-750	

<sup>1)</sup> Includes Adaptor FZ-1630.

\* See warning on this page.

# Grip Puller Sets

▼ Shown: Grip Puller Set BHP-351G



- Precise hydraulic control allows fast, efficient and safe pulling
- High quality, forged steel components provide superior reliability and service
- Available with and without full hydraulic set.

## BHP Series



Capacity:

**8, 20, 30 and 50 ton**

Reach:

**252 - 700 mm**

Spread:

**249 - 1100 mm**

Maximum Operating Pressure:

**700 bar**

### Ordering Example

#### Model Number BHP-251G:

includes Grip Puller BHP-252 and a full hydraulic set. (Hand pump, cylinder, saddle, hose, gauge and gauge adaptor).

#### Model Number BHP-252:

includes Grip Puller mechanical parts **only**, for use with your existing hydraulics.

## ▼ SELECTION CHART

Grip Puller Set Capacity**		8 ton	20 ton	30 ton	50 ton
	Model Number ►	<b>BHP-152<sup>1)</sup></b>	<b>BHP-251G</b>	<b>BHP-351G</b>	<b>BHP-551G</b>
<b>Included Hydraulics</b>	Set Weight ►	22 kg	56 kg	91 kg	160 kg
• Hand Pump		P-142	P-392	P-392	P-80
• Cylinder		RWH-121	RCH-202	RCH-302	RCH-603
• Saddle		-	HP-2015	HP-3015	HP-5016
• Hose		HB-7206QB	HC-7206	HC-7206	HC-7206
• Gauge		GF-120B	GF-813B	GF-813B	GF-813B
• Gauge Adaptor		GA-4	GA-3	GA-3	GA-3
<b>10 Grip Puller</b>	Model Number ►	<b>BHP-1762*</b>	<b>BHP-252*</b>	<b>BHP-352*</b>	<b>BHP-552*</b>
Maximum Spread (mm)	2-jaw	249	400	593	899
	3-jaw	249	499	800	1100
Maximum Reach (mm)	2-jaw	252	300	387	700
	3-jaw	252	300	387	700
Jaw (mm)	Thickness	15	20	24	30
	Width	23	27	38	39
Adjusting Screw (mm)	Thread	$\frac{3}{4}$ "- 16 UNF	1"- 8 UNC	1 $\frac{1}{4}$ "- 7 UNC	1 $\frac{5}{8}$ "- 5.5 UNC
	Length	400	675	795	975
• Case		CW-166	CW-166	CW-350	CW-750

<sup>1)</sup> Includes Adaptor FZ-1630.

\* Grip Puller order number without hydraulics.

\*\* See warning on page 150.

# Cross Bearing Puller Sets

▼ Shown: Cross Bearing Puller Set BHP-361G



- Precise hydraulic control allows fast, efficient and safe pulling
- High quality, forged steel components provide superior reliability and service.

## BHP Series



Capacity:  
**8, 20, 30 and 50 ton**

Reach:  
**354 - 863 mm**

Spread:  
**266 - 570 mm**

Maximum Operating Pressure:  
**700 bar**



The cross bearing puller without hydraulics, bearing cup puller and a bearing puller can be ordered separately, see items nr. 10, 20, 30 and 40.

### ▼ SELECTION CHART

Cross Bearing Puller Set Capacity		8 ton	20 ton	30 ton	50 ton	
	Model Number ▶	<b>BHP-162</b> <sup>1)</sup>	<b>BHP-261G</b>	<b>BHP-361G</b>	<b>BHP-561G</b>	
	Set Weight ▶	26 kg	62 kg	121 kg	185 kg	
•	Hand Pump	P-142	P-392	P-392	P-80	
•	Cylinder	RWH-121	RCH-202	RCH-302	RCH-603	
•	Saddle	–	HP-2015	HP-3015	HP-5016	
•	Hose	HB-7206QB	HC-7206	HC-7206	HC-7206	
•	Gauge	GF-120B	GF-813B	GF-813B	GF-813B	
•	Gauge Adaptor	GA-4	GA-3	GA-3	GA-3	
<b>20</b>	<b>Cross Bearing Puller</b> <sup>2)</sup>	Model Number ▶	<b>BHP-1772</b>	<b>BHP-262</b>	<b>BHP-362</b>	<b>BHP-562</b>
	Spread (mm)	Maximum	266	351	454	570
		Minimum	106	139	179	220
	Reach (mm)	Maximum	462	571	711	863
	Adjusting Screw (mm)	Diameter	3/4" - 16 UNF	1" - 8 UNC	1 1/4" - 7 UNC	1 5/8" - 5.5 UNS
			Length	400	675	795
	Leg (mm)	Length	105	239	203	609
		Length	354	419	457	863
		Length	–	571	711	–
		Length	–	114	–	–
	Upper Leg Ends (mm)	Thread	3/4" - 16 x 25	3/4" - 16 x 25	1-14 x 35	1 1/4" - 12 x 38
	Lower Leg Ends (mm)	Thread	5/8" - 18 x 25	5/8" - 18 x 25	1-14 x 27	1 1/4" - 12 x 38
<b>30</b>	<b>Bearing Cup Puller</b> <sup>2)</sup>	Model Number ▶	<b>BHP-180</b>	<b>BHP-280</b>	<b>BHP-380</b>	<b>BHP-580</b>
<b>40</b>	<b>Bearing Puller</b> <sup>2)</sup>	Model Number ▶	<b>BHP-181</b>	<b>BHP-282</b>	<b>BHP-382</b>	<b>BHP-582</b>
•	Wooden Case		CM-6	CW-187	CW-350	MK-05

<sup>1)</sup> Includes Adaptor FZ-1630.

<sup>2)</sup> Can be ordered separately without hydraulic components, see next page.



# Bearing Cup and Bearing Pullers

▼ Shown: **BHP-380**



## Bearing Cup Puller

- Made of high strength steel alloy
- Easily adapted to Cross Bearing Pullers for fast and efficient removal of the most difficult parts
- Adjustable to fit a variety of bearings and seals.

## BHP Series



Capacity:

**8, 20, 30 and 50 ton**

Maximum Reach:

**110 - 145 mm**

Spread Range:

**110 - 359 mm**

Maximum Operating Pressure:

**700 bar**

### ▼ SELECTION CHART

Capacity *		8 ton	20 ton	30 ton	50 ton
<b>30 Bearing Cup Puller</b>					
Model Number		BHP-180	BHP-280	BHP-380	BHP-580
Spread (mm)	Max.	110	220	359	359
	Min.	26	25	50	50
Reach (mm)	Max.	110	140	145	145
	Center Screw Thread	3/4"- 16 UNF	1"- 8 UNC	1 1/4"- 7 UNC	1 5/8"- 5.5

\* Puller capacity, not attachment capacity. See warning on this page.



### WARNING

Do not exceed 50% of the rated puller capacity when using a double crosshead (2 grip arms) or when using puller legs in combination with bearing puller attachment.

▼ Shown: **BHP-382**



## Bearing Puller

- Made of high strength steel alloy
- Wedge-shaped edges allow removal of the most hard-to-grip components
- Easily adapted to Cross Bearing Pullers for fast and efficient removal of the most difficult parts.

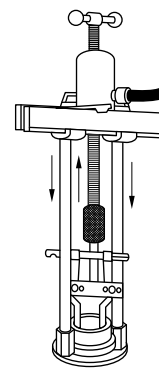

◀ Bearing Cup Puller shown with Crosshead Puller Attachment.

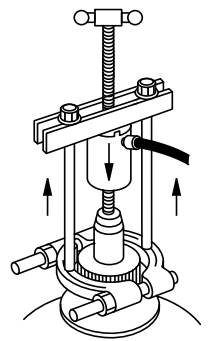

Bearing Puller shown with Crosshead Puller Attachment. ▶

### ▼ SELECTION CHART

Capacity*		8 ton	20 ton	30 ton	50 ton
<b>40 Bearing Puller</b>					
Model Number		BHP-181	BHP-282	BHP-382	BHP-582
Spread (mm)	Max.	104	130	245	245
	Min.	25	9	17	17
Width (mm)		126	150	264	264
Thread		5/8"-18 UNF	5/8"- 18 UNF	1"- 14 UNS	1 1/4"- 12 UNF

\* Puller capacity, not attachment capacity. See warning on this page.



### Bearing Puller

Bearing Puller has wedge shaped edges for placing puller behind hard to reach bearings, gears, etc., where clearance prevents direct application of grip puller arms. The Bearing Puller can be used with the Cross Bearing Puller or the Grip Puller.



▼ Shown from left to right: EP-206, EP-108



- Patented 'Safety Cage' jaw retention system
- Roll threaded shafts for less effort when applying high torque
- Slim tapered jaws for improved gripping in tight spots
- Available in 2 and 3 jaw design and inside and outside pulling configuration
- More efficient pulling, as one man can do the job where manual pullers often require two operators.



◀ Positioning an EP-104 3-jaw puller on the accessory drive of a diesel engine.

## For Safer and Faster Pulling



### Long Jaws

Long Jaws are used to increase the reach and spread of manual pullers. They maintain the same pulling capacity as the standard jaws, but reduce clamping force to 25%.

Page: 157



### Shaft Attachments

Shaft protectors and extenders are live centers that fit over the standard puller shaft for tip protection and additional reach.

Page: 157



### Application Tip

Because of the unique safety cage design, Posi Lock® pullers will grip on surfaces where normal pullers would slip off; e.g. tapered bearings.

# Posi Lock® Mechanical Grip Pullers

## External Posi Lock® Pullers

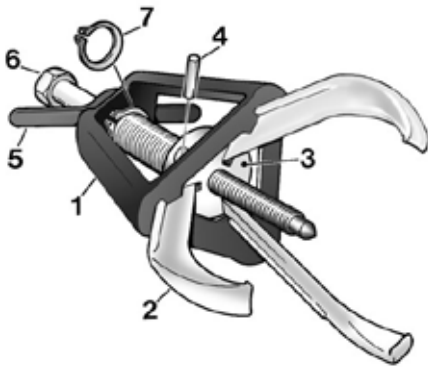

- 1 Patented 'Safety Cage' guides jaws, holding them securely onto the part.
- 2 Durable forged jaws provide positive grip.
- 3 Jaw head provides pivot and reaction point for jaws.
- 4 Pin, for easy jaw removal and replacement.
- 5 T-handle provides control of the puller jaws.
- 6 Drive bolt with rolled threads for increased force with reduced input torque.
- 7 Snap-ring retains cage to drive bolt and provides quick removal for easy service.

## EP EPPMI Series



Capacity:

**2 - 40 ton**

Maximum Reach:

**101 - 355 mm**

Spread Range:

**12 - 635 mm**

### ▼ QUICK SELECTION CHART EXTERNAL PULLERS

For quick technical information see next page.

Number of Jaws	Maximum Reach (mm)	Spread (mm) min. - max.	Capacity ton (kN)	Model Number	Center Bolt Diameter (mm)	 (kg)
2	101	12 - 127	2 (17)	EP-204	14	1,4
3	101	12 - 127	5 (45)	EP-104	14	1,8
2	152	12 - 178	6 (53)	EP-206	16	3,2
3	152	12 - 178	10 (89)	EP-106	16	3,6
2	203	19 - 304	12 (106)	EP-208	20	5,4
3	203	19 - 304	17 (151)	EP-108	20	6,4
2	245	25 - 381	14 (124)	EP-210	20	5,9
3	245	25 - 381	20 (178)	EP-110	20	7,3
2	304	63 - 457	25 (222)	EP-213	29	17,2
3	304	63 - 457	30 (267)	EP-113	29	20,0
2	355	76 - 635	35 (311)	EP-216	31	25,8
3	355	76 - 635	40 (356)	EP-116	31	30,8



Always wear Safety Goggles while using pullers.

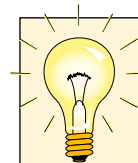

### Application Tip

In determining the correct manual puller capacity for your application, use the following rule:

The center bolt diameter of the puller should be at least ½ the diameter of the shaft being pulled on.

### Example:

A part being pulled from a shaft with a diameter of 38 mm would require a puller with a center bolt diameter of at least 19 mm.

## Internal Posi Lock® Puller

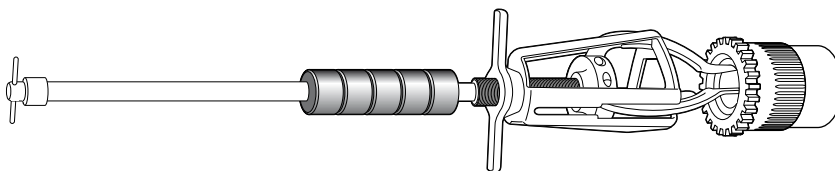

### ▼ QUICK SELECTION CHART INTERNAL PULLERS

Number of Jaws	Maximum Reach (mm)	Spread (mm) min. - max.	Jaw Style	Model Number	Jaw Length (mm)	 (kg)
3	168	14 - 101	Standard	EPPMI-6	168	3,9
	218	25 - 133	Long		218	3,9

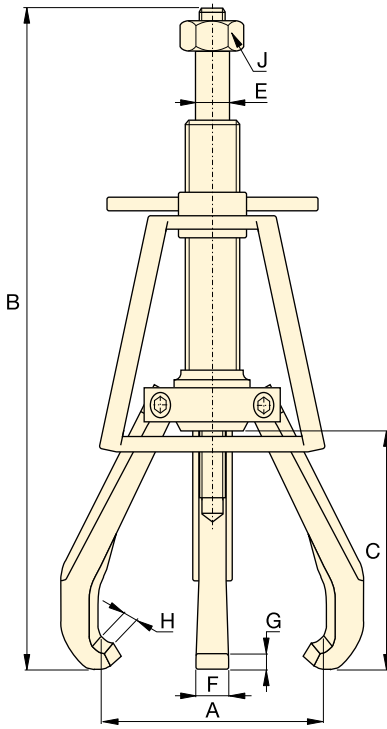

**2 and 3 Jaw External Puller  
EP-Series**

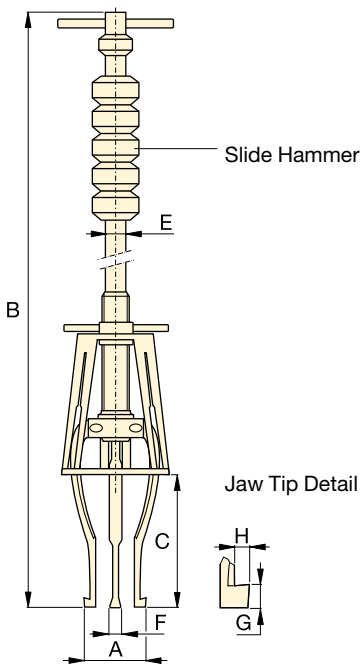

**Internal Puller  
EPPMI-6**



▲ EP-204 2 jaw puller positioned to pull a water pump drive pulley.

### ▼ QUICK SELECTION CHART EXTERNAL PULLERS

Number of Jaws	Maximum Reach (mm)	Spread (mm) min. - max.	Capacity ton (kN)	Model Number	Center Bolt Diameter (mm)	Maximum Torque (Nm)
3	101	12 - 127	5 (45)	EP-104	14	54
2	152	12 - 178	6 (53)	EP-206	16	102
3	152	12 - 178	10 (89)	EP-106	16	176
2	203	19 - 304	12 (106)	EP-208	20	203
3	203	19 - 304	17 (151)	EP-108	20	298
2	245	25 - 381	14 (124)	EP-210	20	237
3	245	25 - 381	20 (178)	EP-110	20	373
2	304	63 - 457	25 (222)	EP-213	29	644
3	304	63 - 457	30 (267)	EP-113	29	814
2	355	76 - 635	35 (311)	EP-216	31	1085
3	355	76 - 635	40 (356)	EP-116	31	1153

### ▼ QUICK SELECTION CHART INTERNAL PULLERS

Number of Jaws	Maximum Reach (mm)	Spread (mm) min. - max.	Jaw Style	Model Number	Jaw Length (mm)	Slide-Hammer weight (kg)
	218	25 - 133	Long		218	1,1

# Posi Lock® Mechanical Grip Pullers



## Shaft Attachments

Shaft protectors and extenders are live centers that fit over the standard puller shaft for tip protection and additional reach.



## Long Jaws

Long Jaws are used to increase the reach and spread of pullers. They maintain the same pulling capacity as the standard jaws, but reduce clamping force to 25% of rating.

## EP EPPMI Series



Capacity:

**2 - 40 ton**

Maximum Reach:

**101 - 355 mm**

Spread Range:

**12 - 635 mm**

Length (mm)	Dia- meter (mm)	Increases Center Bolt Length (mm)	Order: Model Number
25	19	9	<b>EPP-4</b>
50	19	38	<b>EPX-4</b>
31	22	12	<b>EPP-6</b>
50	22	38	<b>EPX-6</b>
31	25	12	<b>EPP-10</b>
50	25	38	<b>EPX-10</b>
50	35	21	<b>EPP-1316</b>

Spread (mm) min. - max.	Max. Reach (mm)	Order: Model Number
57 - 381	245	<b>EP-11054</b>
38 - 558	400	<b>EP-11054L</b>
38 - 762	508	<b>EP-11354L</b>
25 - 133	218	<b>EP-10554L*</b>

\* for EPPMI-6 only

Dimensions (mm)									Model Number	Optional accessories		
Spread min. - max.	Overall Length	Max. Reach	Center Bolt Diam.	Jaw Width	Tip Clearance	Tip Depth	Hex Socket Size (inch) J			Shaft Protectors	Shaft Extenders	Long Jaws
A	B	C	E	F	G	H						
12 - 127	245 - 323	101	14	15	4,1	4,6	7/8	<b>EP-204</b>	<b>EPP-4</b>	<b>EPX-4</b>	-	
12 - 127	245 - 323	101	14	15	4,1	4,6	7/8	<b>EP-104</b>	<b>EPP-4</b>	<b>EPX-4</b>	-	
12 - 178	323 - 476	152	16	19	8,1	6,1	1 1/16	<b>EP-206</b>	<b>EPP-6</b>	<b>EPX-6</b>	-	
12 - 178	323 - 476	152	16	19	8,1	6,1	1 1/16	<b>EP-106</b>	<b>EPP-6</b>	<b>EPX-6</b>	-	
19 - 304	412 - 615	203	20	22	6,4	9,1	1	<b>EP-208</b>	<b>EPP-10</b>	<b>EPX-10</b>	<b>EP-11054</b>	
19 - 304	412 - 615	203	20	22	6,4	9,1	1	<b>EP-108</b>	<b>EPP-10</b>	<b>EPX-10</b>	<b>EP-11054</b>	
25 - 381	489 - 736	245	20	25	6,4	9,1	1	<b>EP-210</b>	<b>EPP-10</b>	<b>EPX-10</b>	<b>EP-11054L</b>	
25 - 381	489 - 736	245	20	25	6,4	9,1	1	<b>EP-110</b>	<b>EPP-10</b>	<b>EPX-10</b>	<b>EP-11054L</b>	
63 - 457	660 - 965	304	29	31	12,7	9,7	1 11/16	<b>EP-213</b>	<b>EPP-1316</b>	-	<b>EP-11354L</b>	
63 - 457	660 - 965	304	29	31	12,7	9,7	1 11/16	<b>EP-113</b>	<b>EPP-1316</b>	-	<b>EP-11354L</b>	
76 - 635	800 - 1155	355	31	36	13,5	11,7	1 13/16	<b>EP-216</b>	<b>EPP-1316</b>	-	-	
76 - 635	800 - 1155	355	31	36	13,5	11,7	1 13/16	<b>EP-116</b>	<b>EPP-1316</b>	-	-	

Note: Overall length (B) is dependent on position of center bolt.

Dimensions (mm)							Model Number
Spread min. - max.	Overall Length	Max. Reach	Slide Rod Dia.	Jaw Width	Tip Clearance	Tip Depth	
A	B	C	E	F	G	H	
14 - 101	736	168	14,2	8	3,0	1,5	<b>EPPMI-6</b>
25 - 133	787	218	14,2	8	7,6	4,6	



Always wear Safety Goggles while using pullers.



▼ Shown: EPHR-110



- Patented 'Safety Cage' jaw retention system
- High force hydraulic system for effortless pulling of large components
- Slim tapered jaws for better gripping in tight spots
- Available in 2 and 3 jaw design
- More efficient pulling, as one man can do the job where manual pullers often require two operators.

## High-Tech Pulling



### Transport and Store

Conveniently stores and transports hydraulic pullers and accessories. Order the **EPT-2550** Storage Cart and make your job easier to do!



### Long Jaws

Used to increase the reach and spread of pullers. They maintain the same pulling capacity as the standard jaws, but reduce clamping force to 25%.

Page: 160



### Application Tip

Because of the unique safety cage design, Posi Lock® pullers will grip on surfaces where normal pullers would slip off; e.g. tapered bearings.



◀ EPHR-116 used to remove electric motor pulleys. Puller is positioned using the Lift Plate.

### ▼ SELECTION CHART

Number of Jaws	Maximum Spread	Capacity	Model Number*
	(mm)	ton (kN)	
2	304	10 (101)	EPH-208
3	304		EPH-108
2	381	15 (142)	EPH-210
3	381		EPH-110
2	457	25 (232)	EPH-213
3	457		EPH-113
2	635	50 (498)	EPH-216
3	635		EPH-116

\* Cylinder is not included.

# Posi Lock® Hydraulic Grip Pullers

## ▼ SETS SELECTION CHART

Style	Capacity (ton)	Basic Puller	Cylinder	Stroke (mm)	Pump Set	Set Model Number*	 (kg)
2 Jaw Puller	10	EPH-208	RC-106	152	-	<b>EPHR208</b>	10
	10	EPH-208	RC-106	152	EP-1E	<b>EPHS208E</b>	27
	15	EPH-210	RC-1510	254	-	<b>EPHR210</b>	22
	15	EPH-210	RC-1510	254	EP-1E	<b>EPHS210E</b>	38
	25	EPH-213	RC-2514	362	-	<b>EPHR213</b>	44
	25	EPH-213	RC-2514	362	EP-1E	<b>EPHS213E</b>	53
	50	EPH-216	RC-5013	336	-	<b>EPHR216</b>	87
50	EPH-216	RC-5013	336	EP-2E	<b>EPHS216E</b>	123	
3 Jaw Puller	10	EPH-108	RC-106	152	-	<b>EPHR108</b>	11
	10	EPH-108	RC-106	152	EP-1E	<b>EPHS108E</b>	28
	15	EPH-110	RC-1510	254	-	<b>EPHR110</b>	23
	15	EPH-110	RC-1510	254	EP-1E	<b>EPHS110E</b>	39
	25	EPH-113	RC-2514	362	-	<b>EPHR113</b>	48
	25	EPH-113	RC-2514	362	EP-1E	<b>EPHS113E</b>	57
	50	EPH-116	RC-5013	336	-	<b>EPHR116</b>	91
	50	EPH-116	RC-5013	336	EP-2E	<b>EPHS116E</b>	127

\* Standard set EPHS models shipped with 230 VAC pump.

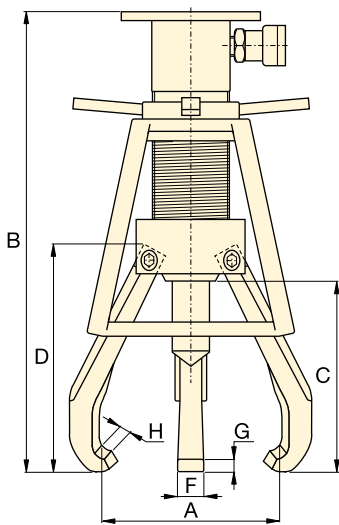

## EPH Series



Capacity:

**10 - 50 ton**

Maximum Reach:

**203 - 355 mm**

Spread Range:

**19 - 635 mm**

Maximum Operating Pressure:

**700 bar**



### Pump Sets

All Posi Lock® Hydraulic Puller Sets that include 230 VAC pumps, will feature the following components:

	EP-1E Pump Set	EP-2E Pump Set
Pump	PUJ-1200E	ZE4210ME
Hose	HC-7210	HC-7210
Gauge	G-2535L	G-2535L
Adaptor	-	GA-3

Components for 115 VAC pumps are available on request.

### Accessories <sup>1)</sup>

#### Standard included

#### Optional



#### Ram Point Sets



#### Lift Plates

#### Long Jaws

Dimensions (mm)							 (kg)	Model Number*			
Spread min. - max.	Overall Length	Maximum Reach	Jaw Length	Jaw Width	Tip Clearance	Tip Depth					
A	B	C	D	F	G	H	(kg)				
19 - 304	498	203	237	22	7,4	6,9	6,4	<b>EPH-208</b>	EPH-155	EPH-11052	<b>EPH-11054</b>
19 - 304	498	203	237	22	7,4	6,9	7,3	<b>EPH-108</b>	EPH-155	EPH-11052	<b>EPH-11054</b>
25 - 381	665	245	270	25	11,2	9,1	10,0	<b>EPH-210</b>	EPH-155	EPH-11052	<b>EPH-11054L</b>
25 - 381	665	245	270	25	11,2	9,1	11,3	<b>EPH-110</b>	EPH-155	EPH-11052	<b>EPH-11054L</b>
63 - 457	846	304	348	31	12,9	9,7	21,3	<b>EPH-213</b>	EPH-257	EPH-11352	<b>EPH-11354L</b>
63 - 457	846	304	348	31	12,9	9,7	25,0	<b>EPH-113</b>	EPH-257	EPH-11352	<b>EPH-11354L</b>
76 - 635	919	355	413	36	15,0	11,7	40,8	<b>EPH-216</b>	EPH-508	EPH-11652	<b>EPH-21654L</b>
76 - 635	919	355	413	36	15,0	11,7	45,4	<b>EPH-116</b>	EPH-508	EPH-11652	<b>EPH-11654L</b>

<sup>1)</sup> See next page for details.

## ▼ RAM POINT SETS SELECTION CHART

Fits Puller Set Model Number	EPH-208, EPH-210 EPH-108, EPH-110	EPH-213 EPH-113	EPH-216 EPH-116
			
Ram Point Set <sup>1)</sup> Model Number	EPH-155	EPH-257	EPH-508
Ram Points Included:	Ram Point Dimensions Diameter x Length (mm)		
Flat Ram Points	ø25 x 25	ø38 x 57	ø51 x 76
	ø25 x 76	ø51 x 57	ø70 x 76
Tapered Ram Points	–	ø51 x 102	ø70 x 127
	ø25 x 38	ø38 x 64	ø51 x 95
	ø25 x 89	ø51 x 64	ø51 x 95
Ram Point Adaptor	–	–	ø70 x 57



Always wear Safety Goggles while using pullers.



<sup>1)</sup> Standard included in EPH-Series Posi Lock Pullers.

## ▼ LIFT PLATE SELECTION CHART

Fits Puller Set Model Number	Model Number *	Thick-ness (mm)	Dia-meter (mm)	
EPH-208	EPH-11052	6,4	ø153	
EPH-108	EPH-11052	6,4	ø153	
EPH-210	EPH-11052	6,4	ø153	
EPH-110	EPH-11052	6,4	ø153	
EPH-213	EPH-11352	9,7	ø203	
EPH-113	EPH-11352	9,7	ø203	
EPH-216	EPH-11652	9,7	ø254	
EPH-116	EPH-11652	9,7	ø254	

\* Mounting screws included. Lifting plates are standard included with EPH-Series Pullers.

## ▼ LONG JAW SELECTION CHART

Fits Puller Set Model Number	Model Number	Number of Jaws required	Spread (mm)	Reach (mm)	 (kg)		Long Jaws are optional accessories and used for added reach and spread. They have the same load capacity as standard jaws with 25% of the clamping force.
EPH-208	EPH-11054	2	57 - 381	246	1,1		
EPH-108	EPH-11054	3	57 - 381	246	1,1		
EPH-210	EPH-11054L	2	38 - 559	401	2,5		
EPH-110	EPH-11054L	3	38 - 559	401	2,5		
EPH-213	EPH-11354L	2	38 - 762	508	4,8		
EPH-113	EPH-11354L	3	38 - 762	508	4,8		

# Posi Lock® 100 Ton Hydraulic Grip Pullers

▼ EPH-1003E



## EPH Series



Capacity:  
**100 ton**

Maximum Reach:  
**1219 mm**

Spread Range:  
**190 - 1778 mm**

Maximum Operating Pressure:  
**700 bar**

- Roller cart with power lift
- Hydraulically actuated lift cylinder on cart extends puller from ground to a height of 1,7 m
- Adjustable jaw tips
- Includes electric one stage pump with remote pendant for fingertip control of the removal process
- Puller height range 673 to 1690 mm
- Multiple pushing adaptors included.



### Pushing Adaptors

All Posi Lock® 100 Ton Hydraulic Pullers include following pushing adaptors.

Diameter (mm)	Length (mm)	Model Number
89	737	EPHT-1162
89	483	EPHT-1163
89	229	EPHT-1164



◀ The EPH-1002E quickly and easily removes this drive coupler from its shaft.

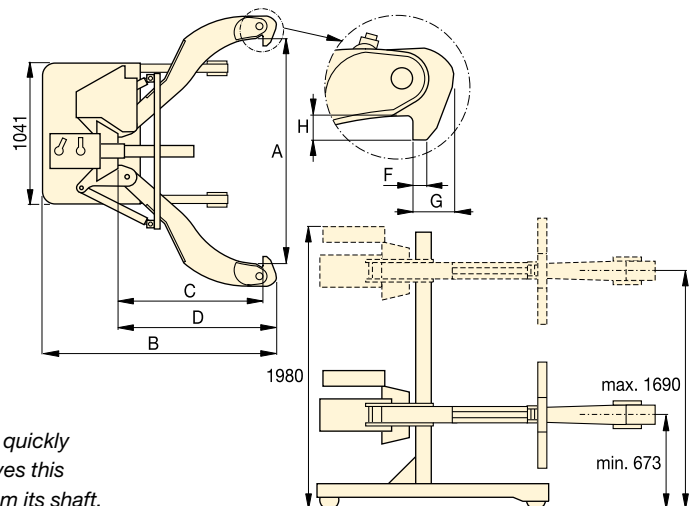

Number of Jaws	Spread Range A (mm)	Capacity ton (kN)	Model Number	Cylinder Stroke (mm)	Overall Length B (mm)	Reach C (mm)	Jaw Length D (mm)	Jaw Width F (mm)	Tip Clearance G (mm)	Tip Depth H (mm)	Weight (kg)
2	190 - 1778	100 (980)	EPH-1002E	250	1955	1219	1346	32	89	89	771
3	190 - 1778	100 (980)	EPH-1003E	250	1955	1219	1346	32	89	89	907



ENERPAC offers an extensive range of dedicated tools for a variety of specific and flexible applications.

Whatever your requirement... cutting, punching, spreading or bending... you can be sure that Enerpac has the correct tool to do your job safely and efficiently.

Featuring maintenance sets, machine lifts and load skates, as well as hole punches, pipe benders and cable cutters, Enerpac has the tools to ensure that even your most demanding applications can be undertaken with the highest degree of safety and accuracy.

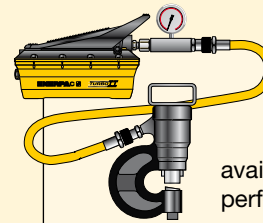

### Tool-Pump Sets

Most hydraulic tools in this section are available in **sets**, for a perfect tool-pump match.



### Hydraulic System Set-up

Check out our 'Yellow Pages' section for help on system set-ups and valving configurations.

Page: 244













### Bolting Tools

More Enerpac Tools you will find in our Bolting Tools section in this catalogue.

Page: 184



# Hydraulic Tools Section Overview

Capacity ton (kN)	Tool type and functions	Series		Page
<b>2,5 - 12,5</b> (22 - 116)	<b>Maintenance Sets</b>	<b>MS</b>		<b>164</b> ▶
<b>35 - 50</b> (311 - 498)	<b>Punch Punch-Pump Sets</b>	<b>MSP</b>		<b>168</b> ▶
		<b>SP</b>		<b>170</b> ▶
<b>16</b> (157)	<b>Lifting Wedge</b>	<b>LW</b>		<b>172</b> ▶
<b>8,5 - 20</b> (75 - 178)	<b>Machine Lifts</b>	<b>SOH</b>		<b>173</b> ▶
<b>1 - 80</b> (8,9 - 712)	<b>Heavy Duty Load Skates</b>	<b>ER ES ELP</b>		<b>174</b> ▶
<b>19 - 453 litres</b>	<b>Industrial Storage Cases</b>	<b>CM</b>		<b>176</b> ▶
<b>0,75 - 1,50</b> (6 - 12)	<b>Hydraulic Wedgie Spread Cylinders</b>	<b>A WR</b>		<b>177</b> ▶
<b>3 - 20</b> (26 - 178)	<b>Hydraulic Cutterheads Cutterhead-Pump Sets</b>	<b>WHC WHR STC</b>		<b>178</b> ▶
<b>3 - 20</b> (26 - 178)	<b>Self-Contained Hydraulic Cutters</b>	<b>WMC</b>		<b>179</b> ▶
<b>Nominal Bore</b> <b>1/2 - 4 inch</b>	<b>Pipe Benders</b>	<b>STB</b>		<b>180</b> ▶
<b>20 - 30</b> (201 - 295) <b>Strands Ø 3/8"- 0.60"</b>	<b>Mono-Strand Stressing Tools</b>	<b>PTJ 5DA 6DA</b>		<b>182</b> ▶

▼ Shown: **MS2-10**



- All sets include Enerpac pump, hose, cylinder and gauge
- Lock-on or threaded connectors
- Complete maintenance set for almost every maintenance application.



◀ *Clamping a workpiece is just one of the many applications for the Enerpac maintenance sets.*

## The Universal Hydraulic Tool Box



### Maintenance Sets

Enerpac Maintenance sets are a complete assortment of hydraulic powered tools. Using these sets allows you to quickly configure a unique tool to meet your most difficult jobs. Built around the Enerpac lightweight hand pump, hose and cylinder, these sets enable you to push, pull, lift, press, straighten, spread and clamp with forces up to 12,5 ton.









### More Information

For detailed information on all included attachments, see the next pages.

Page: 166

### ▼ QUICK SELECTION CHART

Capacity using attachments* ton (kN)	Set Model Number						Number of Attachment Components	 (kg)
2,5 (22)	<b>MS2-4</b>	P-142	HC-7206	RC-55	GP-10S	GA-4	35	26
2,5 (22)	<b>MSFP-5</b>	P-142	HC-7206	RC-55	G2535L	GA-3	24	20
5,0 (50)	<b>MSFP-10</b>	P-392	HC-7206	RC-106	G2535L	GA-3	22	48
5,0 (50)	<b>MS2-10</b>	P-392	HC-7206	RC-106	GP-10S	GA-2	40	63
12,5 (116)	<b>MS2-20</b>	P-392	HC-7206	RC-256	GP-10S	GA-2	19	95
5,0-12,5 (50-116)	<b>MS2-1020</b>	P-392	HC-7206	RC-102, -106, -256	GP-10S	GA-2	59	158

\* If no attachments are being used, capacity is double these values. Maximum operating pressure is then 700 bar.

# Universal Maintenance Sets



**CAUTION!**  
When cylinders are used with maintenance set attachments or components, the maximum system pressure must be limited to half the rated pressure (350 bar).



**WARNING!**  
Only use attachments provided with set. Non-Enerpac attachments and longer extension tubes will reduce column strength, potentially creating unsafe conditions.

**MS Series**



Capacity (using attachments):

**2,5-12,5 ton**

Maximum Operating Pressure:

**350 bar**

## ▼ APPLICATION EXAMPLES





# MS-Series, Maintenance Sets



**CAUTION!** When cylinders are used with maintenance set attachments or components, the maximum system pressure must be limited to half the rated pressure (350 bar).

Note: All dimensions in millimetres.

Set Model Number	MS2-4	MSFP-5	MSFP-10	MS2-10	MS2-20	MS2-1020	
Base/Collar/Plunjer Attachments	2,5 tons	2,5 tons	5,0 tons	5,0 tons	12,5 tons	5 -12,5 tons	
Cylinder(s)	RC-55	RC-55	RC-106	RC-106	RC-256	RC-102,106,256	
<b>1</b>	A-23	A-23	A-13	A-13	A-28	A-13 / A-28	
<b>2</b>	A-25	A-25	A-21	A-21	A-27	A-21 / A-27	
<b>3</b>	A-1034	A-1034	A-20	A-20	A-595	A-20 / A-595	
<b>4</b>	MZ-4010	MZ-4010	A-14	A-14	A-243	A-14 / A-243	
<b>5</b>	A-545	A-545	A-10	A-10	—	A-10 (2x)	
<b>6</b>	—	—	—	A-8	—	A-8	
<b>7</b>	A-530	A-530	A-6	A-6	—	A-6	
<b>8</b>	MZ-4011	—	—	A-192	—	A-192	
<b>9</b>	—	—	—	A-305	—	A-305	
<b>10</b>	A-531	A-531	A-18	A-18	—	A-18	
<b>11</b>	—	—	—	A-185	—	A-185	
<b>12</b>	A-532	A-532	A-15	A-15	—	A-15	
<b>13</b>	—	—	—	—	A-607	A-607	
<b>14</b>	A-629	A-629	A-129	A-129	—	A-129	
<b>15</b>	A-539	A-539	A-128	A-128	—	A-128	
Chains and Attachments for Pulling	2,5 tons	2,5 tons	5,0 tons	5,0 tons	12,5 tons	5-12,5 tons	
<b>16</b>	A-558	—	—	A-132	A-238	A-132, -238	
<b>17</b>	—	—	—	A-5 (2x)	—	A-5 (2x)	
<b>18</b>	A-557(2x)	—	—	A-141(2x)	A-218(2x)	A-141 (2x) / A-218 (2x)	
Tubes, Connectors and Adaptors	2,5 tons	2,5 tons	5,0 tons	5,0 tons	12,5 tons	5-12,5 tons	
<b>19</b>	A-544	—	—	A-19(2x)	A-242(2x)	A-19 (2x) / A-242 (2x)	
<b>20</b>	WR-5	WR-5	WR-5	A-92	—	A-92	
<b>21</b>	MZ-4013(4x)	MZ-4013 (4x)	A-16(4x)	A-16(4x)	—	A-16(4x)	
<b>22</b>	MZ-4007(3x)	MZ-4007(3x)	MZ-1050(2x)	MZ-1050 (2x)	—	MZ-1050 (3x)	
<b>23</b>	MZ-4008(2x)	—	—	MZ-1051	—	MZ-1051 (2x)	
<b>24</b>	MZ-4009	MZ-4009	MZ-1052	MZ-1052	—	MZ-1052	
<b>25</b>	—	—	—	A-285	—	A-285	
<b>26</b>	A-650	—	—	—	—	—	
<b>27</b> Length:76mm	MZ-4002	MZ-4002	—	—	—	—	
 Ø 42,5 mm	127mm	MZ-4003	MZ-4003	MZ-1002	MZ-1002	—	MZ-1002
	254mm	MZ-4004	MZ-4004	MZ-1003	MZ-1003	A-239	MZ-1003 and A-239
	457mm	MZ-4005(2x)	MZ-4005	MZ-1004	MZ-1004	A-240	MZ-1004 (2x) and A-240
	584mm	MZ-4006(2x)	MZ-4006	—	—	—	—
	762mm	—	—	MZ-1005	MZ-1005	A-241	MZ-1005 (2x) and A-241
<b>28</b> Case	CM-6	CM-6	CW-350	CW-350	CW-350	MK-05	
Weight	26 kg	20 kg	48 kg	63 kg	95 kg	158 kg	

## Base/Collar/Plunjer Attachments

### 1 Threaded Adaptor

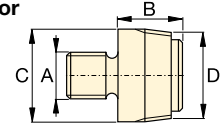

ton	Model Nr.	A	B	C	D
2,5	A-23	3/4" - 16 UN	28	26	3/4" - 14 NPT
5,0	A-13	1" - 8 UN	31	42	1 1/4" - 11 1/2 NPT
12,5	A-28	1 1/2" - 16 UN	47	69	2" - 11 1/2 NPT

### 2 Base Attachment

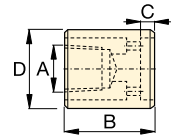

ton	Model Nr.	A	B	C	D
2,5	A-25	3/4" - 14 NPT	50	12	44
5,0	A-21	1 1/4" - 11 1/2 NPT	57	12	65
12,5	A-27	2" - 11 1/2 NPT	63	12	98

### 3 Collar Toe

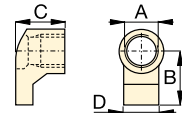

ton	Model Nr.	A	B	C	D
2,5	A-1034	1 1/2" - 16 UN	54	50	31
5,0	A-20	2 1/4" - 14 UN	80	57	57
12,5	A-595	3 5/16" - 12 UN	103	51	80

### 4 Flat Base

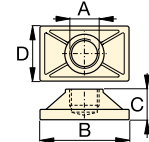

ton	Model Nr.	A	B	C	D
2,5	MZ-4010	3/4" - 14 NPT	114	31	63
5,0	A-14	1 1/4" - 11 1/2 NPT	165	35	88
12,5	A-243*	2" - 11 1/2 NPT	165	58	165

\* A-243 is a round base model

### 5 Threaded Connector

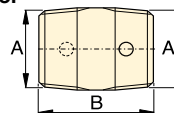

ton	Model Nr.	A	B
2,5	A-545	3/4" - 14 NPT	35
5,0	A-10	1 1/4" - 14 NPT	41

### 6 Lock-on Clamp Toe

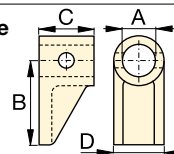

ton	Model Nr.	A	B	C	D
5,0	A-8	43	105	50	57

# Universal Maintenance Sets, MS-Series



ton	Model Nr.	A	B	C	D
2,5	A-530	3/4" - 14 NPT	57	25	33
5,0	A-6	1 1/4" - 11 1/2 NPT	28	31	57

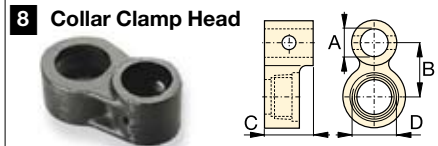

ton	Model Nr.	A	B	C	D
2,5	MZ-4011	3/4" - 14 NPT	49	76	1 1/2" - 16 UN
5,0	A-192	42	63	50	2 1/4" - 14 UN



ton	Model Nr.	A	B	C	D
5,0	A-305	1 1/4" - 11 1/2 NPT	114	25	50

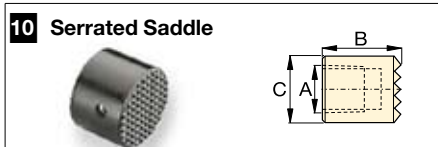

ton	Model Nr.	A	B	C
2,5	A-531	3/4" - 14 NPT	27	31
5,0	A-18	1 1/4" - 11 1/2 NPT	38	50

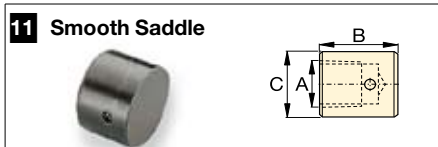

ton	Model Nr.	A	B	C
5,0	A-185	1 1/4" - 11 1/2 NPT	38	50

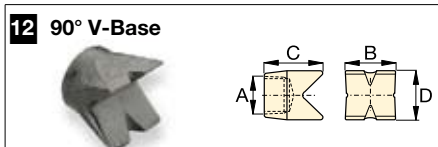

ton	Model Nr.	A	B	C	D
2,5	A-532	3/4" - 14 NPT	38	47	25
5,0	A-15	1 1/4" - 11 1/2 NPT	54	57	54

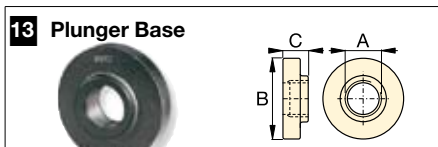

ton	Model Nr.	A	B	C
12,5	A-607	2" - 11 1/2 NPT	166	38



ton	Model Nr.	A	B	C	D
2,5	A-629	3/4" - 14 NPT	69	33	28
5,0	A-129	1 1/4" - 11 1/2 NPT	101	50	44

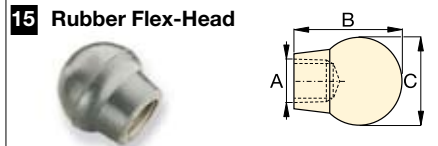

ton	Model Nr.	A	B	C
2,5	A-539	3/4" - 14 NPT	44	69
5,0	A-128	1 1/4" - 11 1/2 NPT	86	86

## Chains and Attachments for Pulling

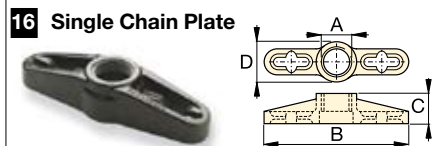

ton	Model Nr.	A	B	C	D
2,5	A-558	1 1/2" - 16 UN	196	39	44
5,0	A-132	2 1/4" - 14 UN	307	63	79
12,5	A-238	3 5/16" - 12 UN	450	102	125

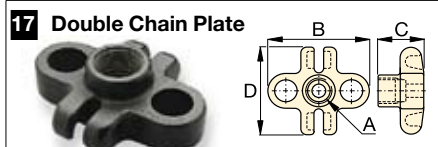

ton	Model Nr.	A	B	C	D
5,0	A-5	1 1/4" - 11 1/2 NPT	130	50	126



ton	Model Nr.	Chain Length
2,5	A-557	1,5 metres
5,0	A-141	1,8 metres
12,5	A-218	2,4 metres

## Tubes, Connectors and Adaptors

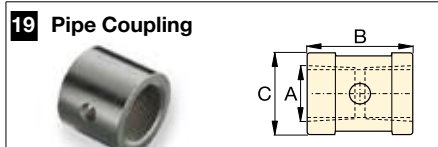

ton	Model Nr.	A	B	C
2,5	A-544	3/4" - 14 NPT	42	33
5,0	A-19	1 1/4" - 11 1/2 NPT	49	54
12,5	A-242	2" - 11 1/2 NPT	88	82

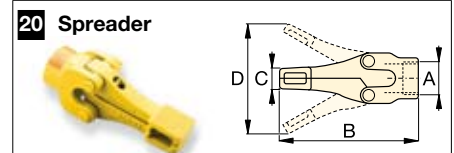

ton	Model Nr.	A	B	C	D
1,0	WR-5	—	223	12,8	94
1,0	A-92	2 1/4" - 14 UN	244	35	158

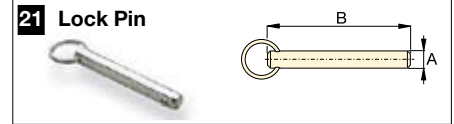

ton	Model Nr.	A	B
2,5	MZ-4013	7,9	41
5,0	A-16	11,2	82

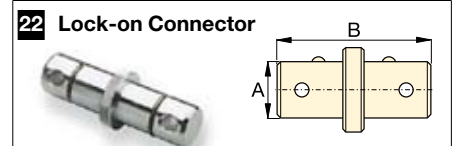

ton	Model Nr.	A	B
2,5	MZ-4007	19	79
5,0	MZ-1050	33	127

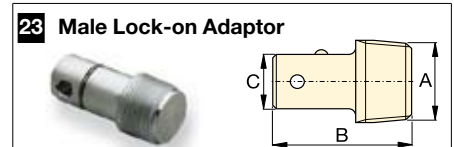

ton	Model Nr.	A	B	C
2,5	MZ-4008	3/4" - 14 NPT	60	19
5,0	MZ-1051	1 1/4" - 11 1/2 NPT	90	33



ton	Model Nr.	A	B	C
2,5	MZ-4009	3/4" - 14 NPT	65	19
5,0	MZ-1052	1 1/4" - 11 1/2 NPT	96	33

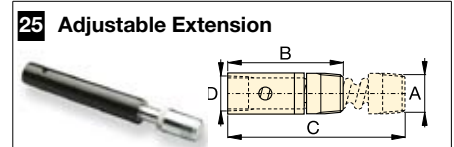

ton	Model Nr.	A	B	C	D
5,0	A-285	1 1/4" - 11 1/2 NPT	335	441	33

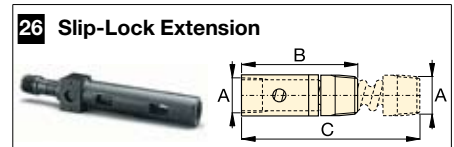

ton	Model Nr.	A	B	C
2,5	A-650	3/4" - 14 NPT	200	365

# SP-Series, Lightweight Hydraulic Punch

▼ Shown: SP-35S



- 12,7 mm thick capacity through mild steel
- Round, oblong and square punches and dies are available to solve your punching applications
- Long life Enerpac single-acting, spring return design
- Durable steel case keeps tools and dies together and provides for easy carrying and storage
- CR-400 coupler included.

## Much Faster than Drilling



### Tool Kit SPK-10

Included with all 35 Ton punches, this tool kit is used to remove and install the punch into the head.

Can be ordered as a replacement under model number **SPK-10**.



### Ordering Information

The 35 ton hydraulic Punch may be ordered by itself or as a set, including a pump.

A punch or die may also be ordered separately or as a matched set. Please refer to the Quick Selection Chart information on top of the next page.

### ▼ STANDARD PUNCHES AND DIES SELECTION CHART

Hole Shape	Imperial**		Metric**	
	Hole Size (inch)	Bolt Size (inch)	Hole Size (mm)	Bolt Size (mm)
●	0,31	1/4	7,9	–
●	0,38	5/16	9,5	M8
●	0,44	3/8	11,1	M10
●	0,53	7/16	13,5	M12
●	0,56	1/2	14,3	–
●	0,69	5/8	17,5	M16
●	0,78	–	19,8	M18
●	0,81	3/4	20,6	–
■	0,31	1/4	7,9	–
■	0,38	5/16	9,5	M8
■	0,44	3/8	11,1	M10
■	0,50	7/16	12,7	M12
■	.31 x .75	1/4	7,9 x 19	–
■	.38 x .75	5/16	9,5 x 19	M8
■	.44 x .75	3/8	11,1 x 19	M10
■	.50 x .75	7/16	12,7 x 19	M12



◀ This PUD-1100E Economy Electric Pump is available as a matched set with the 35 ton punch.

\*\* Material thickness should **not** exceed hole diameter

# Single-Acting, Spring Return Hydraulic Punch

## ▼ QUICK SELECTION CHART

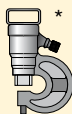
Included						Model Number	 (kg)
	Punch & Die Set	Pump	Hose	Gauge	Gauge Adaptor		
SP-35	Standard**	P-392	HC-7206	GP-10S	GA-2	<b>STP-35H</b>	25
SP-35	Standard**	PATG-1102N	HC-7206	GP-10S	GA-2	<b>STP-35A</b>	29
SP-35	-	-	-	-	-	<b>SP-35</b>	16
SP-35	Standard**	-	-	-	-	<b>SP-35S</b>	18
SP-35	Standard**	PUD-1100E	HC-7206	-	-	<b>SP-35SPE</b>	29
SP-35	Metric***	-	-	-	-	<b>MSP-351</b>	21
SP-35	Metric***	PUD-1100E	HC-7206	-	-	<b>MSP-351PE</b>	32

\* Punch oil capacity: 76 cm<sup>3</sup>

Includes the following punch and die sets:

\*\* SPD-438, SPD-688, SPD-563 and SPD-813

\*\*\* SPD-375, SPD-531, SPD-438 and SPD-688

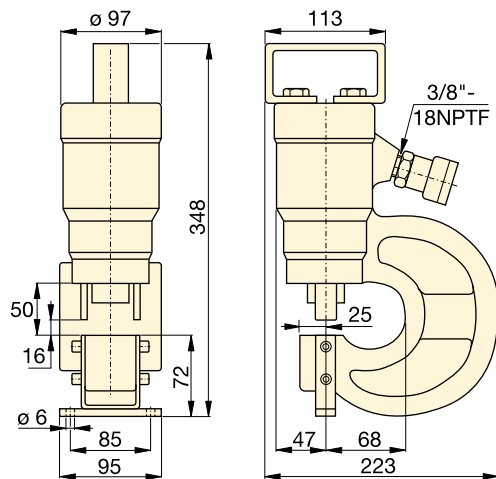

## MSP, SP, STP Series



Capacity:

### 35 ton

Hole Sizes:

### 7,9 - 20,6 mm

Maximum Operating Pressure:

### 700 bar



### CAUTION!

The chart below is for reference only! Maximum allowable material thickness to be punched varies with set wear.



### CAUTION!

Material thickness should **not** exceed hole diameter.

Standard Punch & Die Set 	Maximum allowable material thickness to be punched (mm)											
	Model Numbers	1)	2)	3)	4)	5)	6)	7)	8)	9)	10)	11)
<b>SPD-313</b>	7,9	7,9	6,4	6,4	6,4	6,4	3,3	4,8	6,4	6,4	6,4	6,4
<b>SPD-375</b>	9,7	9,7	7,9	7,9	7,9	7,9	4,8	6,4	7,9	7,9	7,9	7,9
<b>SPD-438</b>	11,2	11,2	9,7	9,7	9,7	7,9	4,8	7,9	7,9	7,9	7,9	7,9
<b>SPD-531</b>	12,7	12,7	11,2	11,2	11,2	9,7	6,4	7,9	9,7	9,7	9,7	9,7
<b>SPD-563</b>	12,7	12,7	12,7	11,2	12,7	11,2	6,4	9,7	11,2	11,2	11,2	11,2
<b>SPD-688</b>	12,7	12,7	12,7	11,2	12,7	10,2	6,4	7,9	10,2	10,2	10,2	10,2
<b>SPD-781</b>	12,7	12,7	12,7	11,2	12,7	9,7	6,4	7,9	9,7	9,9	9,9	9,7
<b>SPD-813</b>	12,7	12,7	12,7	11,2	12,7	7,9	4,8	7,9	7,9	7,9	7,9	7,9
<b>SPD-458</b>	7,9	7,9	6,4	6,4	6,4	6,4	3,3	4,8	6,4	6,4	6,4	6,4
<b>SPD-549</b>	9,7	9,7	7,9	7,9	7,9	7,9	4,8	6,4	7,9	7,9	7,9	7,9
<b>SPD-639</b>	11,2	11,2	9,7	9,7	9,7	7,9	4,8	7,9	7,9	7,9	7,9	7,9
<b>SPD-728</b>	12,7	12,7	11,2	11,2	11,2	9,7	6,4	7,9	9,7	9,7	9,7	8,6
<b>SPD-106</b>	7,9	7,9	6,4	6,4	6,4	6,4	3,3	4,8	6,4	6,4	6,4	6,4
<b>SPD-125</b>	9,7	9,7	7,9	7,9	7,9	7,9	4,8	6,4	7,9	7,9	7,9	7,9
<b>SPD-188</b>	11,2	11,2	9,7	9,7	9,7	7,9	4,8	7,9	7,9	7,9	7,9	7,9
<b>SPD-250</b>	12,7	12,7	11,2	11,2	11,2	9,7	6,4	7,9	9,7	9,7	9,7	9,7

### Steel Qualities (see table):

- 1) Mild A-7
- 2) Boiler Plate
- 3) Structural A-36
- 4) Struct Corten (ASTM A242)
- 5) Cold Rolled C-1018
- 6) Hot Rolled C-1050
- 7) Hot Rolled C-1095
- 8) Hot Rolled C-1095 Annealed
- 9) Stainless Annealed
- 10) Stainless 304 Hot Rolled
- 11) Stainless 316 Cold Rolled



# SP-Series, 50 Ton Hydraulic Punch

▼ Shown: SP-50100



- Available as a complete set including electric pump and hoses
- Double-acting cylinder design for fast cycle times
- Punch and die changeover tools included
- Lifting bracket included
- Adjustable power stripper prevents movement of the metal during stripping
- CR-400 female couplers included.



◀ Save time using the 50-ton Enerpac Punch.

## Cuts the Time Spent Forming Holes



### Depth Stop

For simplified repetitive punching applications an adjustable Depth Stop is available.

Order model number:  
**SP-110.**



### Foot Mounting Kit

A foot mounting kit for easy mounting of the 50 ton punch to workbench or fixture is available.

Order model number:  
**SP-120.**



### Ordering Information

The 50-ton Hydraulic Punch may be ordered by itself or as a set with an electric pump. A punch and die may be ordered as a matched set. Please refer to the selection chart information.

▼ Shown below is the 50 ton punch with SP-120 and SP-110 assembled.



# 50 Ton Double-Acting Hydraulic Punch

## ▼ QUICK SELECTION CHART PUNCH SETS

Model Number Punch*	Included			Set Model Number	Weight (kg)
	Punch & Die Sets 	Pump	Hose (2x)		
SP-50	All**	—	—	SP-50100	116
SP-50	All**	ZE4410SE	HC-7206	SP-5000	174

\* Punch Oil Capacity:  
Advance: 278 cm<sup>3</sup>  
Retract: 229 cm<sup>3</sup>

\*\* All standard sets from chart below.

## SP Series



Capacity:

**50 ton (490 kN)**

Hole Sizes:

**13,5 - 26,2 mm**

Maximum Operating Pressure:

**700 bar**

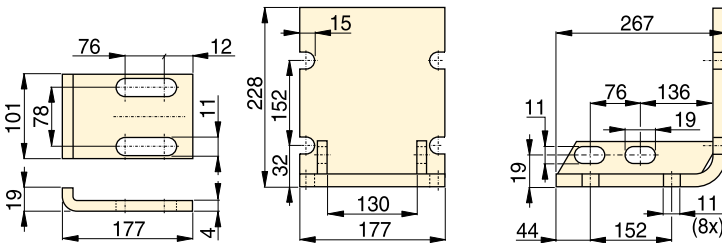

SP-110

SP-120

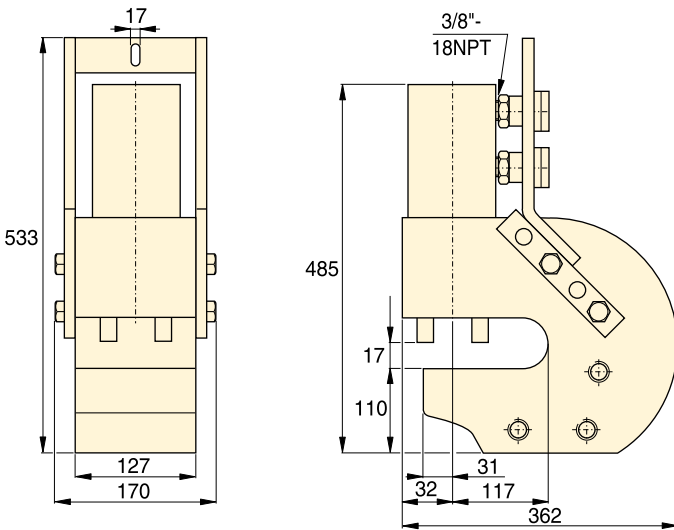

SP-50



### CAUTION!

Material thickness should not exceed hole diameter.



### CAUTION!

Chart below is for reference only! Maximum allowable material thickness to be punched varies with set wear.

### Steel Qualities (see table below):

- 1) Mild A-7
- 2) Boiler Plate
- 3) Structural A-36
- 4) Struct Corten (ASTM A242)
- 5) Cold Rolled C-1018
- 6) Hot Rolled C-1050
- 7) Hot Rolled C-1095
- 8) Hot Rolled C-1095 Annealed
- 9) Stainless Annealed
- 10) Stainless 304 Hot Rolled
- 11) Stainless 316 Cold Rolled

## ▼ STANDARD PUNCH AND DIE SELECTION CHART

Hole Shape	Hole Size (mm)	Bolt Size (mm)	Standard Punch and Die Set  Model Numbers	Maximum Allowable Material Thickness To Be Punched (mm)										
				1)	2)	3)	4)	5)	6)	7)	8)	9)	10)	11)
●	13,5	M12	SP-150	13,5	13,5	13,5	13,5	13,5	12,4	8,1	10,2	12,4	12,4	12,4
●	16,7	M16	SP-170	—	—	—	—	—	13,0	8,1	10,2	13,0	13,0	13,0
●	19,8	M18	SP-190	—	—	—	—	—	12,4	8,1	10,2	12,4	12,7	12,4
●	23,1	M20	SP-121	14,2	14,2	14,2	12,7	14,2	8,9	5,6	8,9	8,9	8,9	8,9
●	26,2	M24	SP-123	14,2	14,2	14,2	11,2	14,2	7,9	4,8	7,9	7,9	7,9	7,9

# Hydraulic Vertical Lifting Wedge

▼ LW-16 with SB-2 and optional LWB-1



## LW Series

Maximum Lifting Force:

**16 ton**

Lifting Stroke:

**21 mm**

Tip Clearance / Maximum Spread\*:

**10 mm / 81,5 mm**

Maximum Operating Pressure:

**700 bar**



### Best Match Hand Pump

To power your Enerpac Machine Lift, the Enerpac **P-392** hand pump is an ideal choice.

Page: **66**

- Requires very small access gap of only 10 mm
- Lifting force 16 ton at 700 bar hydraulic pressure
- Each step can spread under full load
- Straight vertical lifting
- Unique interlocking wedge design: no first step bending and risk of slipping out
- Single-acting, spring return cylinder
- Lifting wedge LW-16 includes safety block SB-2
- Includes RC-Series Cylinder with CR-400 coupler.



### Control Manifolds

Control Manifold to control two or four lifting wedges simultaneously.

**AM-21** with 3 ports 3/8" NPTF  
**AM-41** with 5 ports 3/8" NPTF.

Page: **124**

▼ For lifting heavy equipment with minimum floor clearance the LW-16 is the ideal tool.

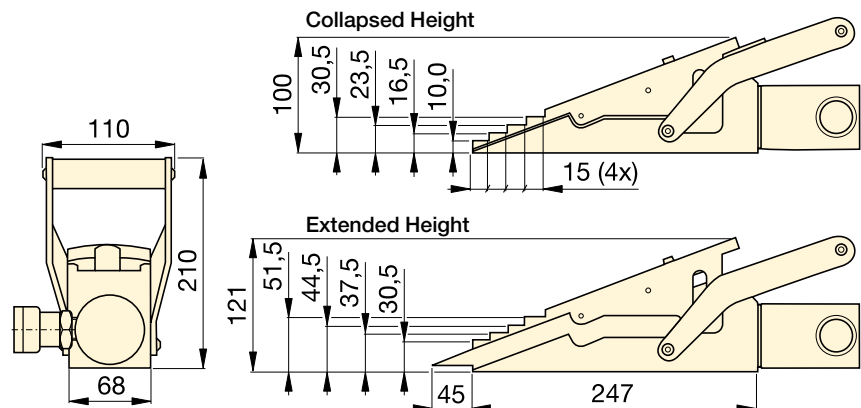

Maximum Lifting Force ton (kN)	Lifting Stroke (mm)	Model Number	Tip Clearance (mm)	Maximum Operating Pressure (bar)	Oil Capacity (cm <sup>3</sup> )	 (kg)
<b>16 (157)</b>	21	<b>LW-16</b>	10	700	78	9,0

Use optional stepped block LWB-1 to increase wedge lifting height by 30 mm.

\* Using LWB-1.

# Hydraulic Machine Lifts

▼ Shown: **SOH-10-6**



## SOH Series

Lifting Capacity:

**8,5 - 20 ton**

Stroke:

**136 - 157 mm**

Toe Clearance:

**20 mm**

Maximum Operating Pressure:

**700 bar**



### RSM Flat-Jac®

Low height, single acting spring-return cylinders are ideal for space restricted applications.

Page: 22

- For lifting heavy equipment with minimum available access
- Remote hydraulic pump enhances safety
- Low height lifting toe
- Precision guided to reduce friction and isolate cylinder from side-loads
- Two extendable support feet provide extra stability
- Includes RC-Series Cylinder with CR-400 coupler.



### Load Skates

In combination with the Enerpac Machine Lifts we recommend Load Skates for moving heavy loads.

Page: 174

▼ Limited access under this machine makes the Enerpac hydraulic machine lift the perfect solution.

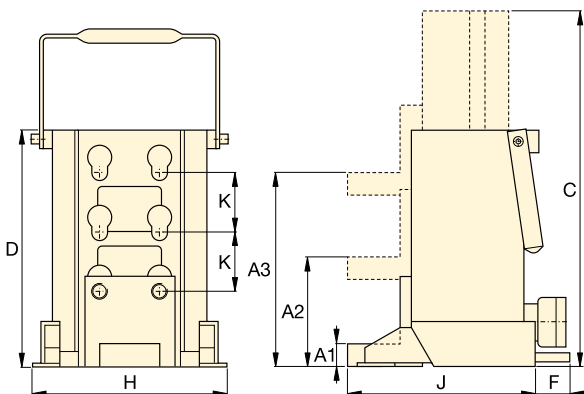

Capacity	Toe Clearance (mm)			Stroke	Model Number	Oil Capacity	Dimensions (mm)						🏋️ (kg)
	Minimum A1	Central A2	Maximum A3				Total Ext. Height C	Total Body Height D	F	H	J	K	
8,5 (75)	20	95	169	136	<b>SOH-10-6</b>	224	430	294	–	190	214	74	26
20 (178)	30	110	190	157	<b>SOH-23-6</b>	525	472	320	65	265	250	80	45



# Heavy Duty Caterroller™ Load Skates

▼ Shown: Set ERS-20



- Rugged and sturdy construction for long life
- Low profile construction for increased stability
- Low rolling-resistance allows for easy transportation
- Attachable load leveling plates and swivel turntables for turning corners.

## Move Heavy Loads Easily and Safely

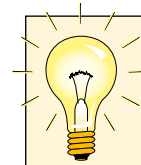

Sets (see table) include all components necessary to handle a variety of applications.

Two **ELB-1** link-up bars, two **ERH-1** handles (880 mm long) and one **EMB-1** metal box are included.

Optional long handle **ERH-2** (1295 mm) available for 60 and 80 ton only.



### Lifting Wedge and Machine Lifts



To place the Load Skates, the load must first be lifted.

This can be done easily and safely using the Enerpac Lifting Wedge or Machine Lifts.

Page: 172

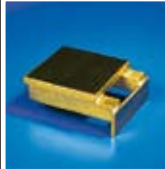

▼ Load Skates may be ordered separately or as a matched set.

Set Capacity*	Set Model Number	Load Skates (4x)	Turntable Swivels (2x)	Leveling Plates (2x)	Weight Including handles and metal box
ton (kN)					(kg)
20 (178)	<b>ERS-20</b>	ER-10	ES-10	ELP-10	49
30 (267)	<b>ERS-30</b>	ER-15	ES-15	ELP-15	55
60 (533)	<b>ERS-60</b>	ER-30	ES-30	ELP-30	75

\* Sets are designed to enable two skates to take full load for extra safety on uneven floor surfaces

◀ Heavy transport using Load Skates. The machine is first lifted, using SOH-Series Enerpac Machine Lifts.

# Heavy Duty Caterroller™ Load Skates

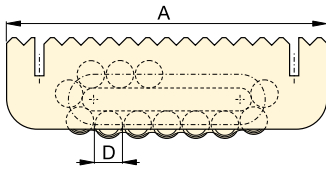

ER-1, ER-10, ER-15, ER-30

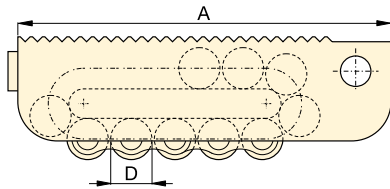
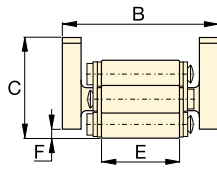

ER-60, ER-80

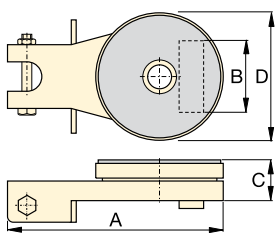
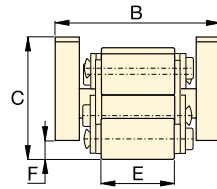

Turntable Swivel  
ES-1, ES-10, ES-15, ES-30

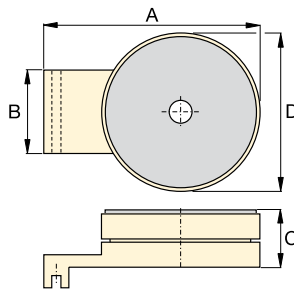

Turntable Swivel  
ES-60, ES-80

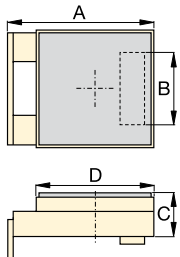

Leveling Plate  
ELP-10, ELP-15, ELP-30

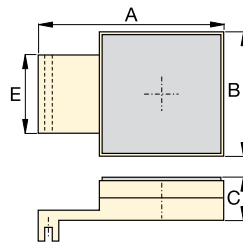

Leveling Plate  
ELP-60, ELP-80



**EL  
ER  
ES  
Series**



Maximum Carrying Capacity:  
**80 ton**

▼ Chemical tank transportation: The first few centimetres the load was lifted with RCS-Series low height cylinders and then moved on to load skates for transportation.

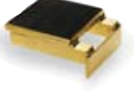

	Capacity* ton (kN)	Model Number	Dimensions (mm)						Contact Rolls per Skate	Rollers per Skate	⚖️ (kg)
			A	B	C	D	E	F			
 Load Skates	1 (8,9)	ER-1	160	100	65	18	51	4	4	11	3,8
	10 (89)	ER-10	210	102	66	18	51	6	5	15	5,2
	15 (133)	ER-15	220	115	75	24	60	10	4	13	7,3
	30 (267)	ER-30	270	130	92	30	68	10	4	13	13,0
	60 (533)	ER-60	380	168	125	42	76	16	4	13	31,9
	80 (711)	ER-80	530	182	145	50	86	19	6	17	60,9
 Turntable Swivel	1 (8,9)	ES-1	207	86	26	90	-	-	-	-	1,1
	10 (89)	ES-10	220	73	42	130	-	-	-	-	3,7
	15 (133)	ES-15	220	86	42	130	-	-	-	-	3,7
	30 (267)	ES-30	250	96	48	150	-	-	-	-	5,3
	60 (533)	ES-60	275	114	61	190	-	-	-	-	13,7
	80 (711)	ES-80	360	128	61	220	-	-	-	-	18,9
 Leveling Plate	10 (89)	ELP-10	149	73	42	120	-	-	-	-	3,7
	15 (133)	ELP-15	149	86	42	120	-	-	-	-	3,7
	30 (267)	ELP-30	178	96	48	130	-	-	-	-	5,3
	60 (533)	ELP-60	270	114	61	180	-	-	-	-	13,8
	80 (711)	ELP-80	350	128	61	200	-	-	-	-	18,8

▼ CM-16



- Protect your equipment from dust, water, grease and dirt
- Reduce losses on the jobsite, maintenance area or shop
- Durable steel, painted with rust-resistant primer and finished in durable enamel
- Heavy duty hinges and lifting handles
- Lockable.

▼ When not storing the lifting system, this heavy-duty storage case doubles as a work station.



## CM Series

Case Size:

**19 - 453 litres**

## Protect your Equipment



### Maintenance Sets

Enerpac Maintenance sets are a complete assortment of hydraulic powered tools. Using these sets allows you to quickly configure a unique tool to meet your most difficult jobs. Built around the Enerpac lightweight hand pump, hose and cylinder, these sets enable you to push, pull, lift, press, straighten, spread and clamp with forces up to 12,5 ton.

Page: **164**



### Hydraulic Pullers

These hydraulic pullers eliminate time-consuming and unsafe hammering, heating or prying. Damage to parts is minimized through the use of controlled hydraulic power.

Page: **151**

Case Size (litres)	Model Number	Dimensions L x W x H (mm)	Thickness (mm)	 (kg)
19	<b>CM-6</b>	597 x 178 x 178	0,9	7
32	<b>CM-1</b>	635 x 292 x 168	0,9	8
127	<b>CM-4</b>	787 x 457 x 355	1,5	16
212	<b>CM-7</b>	1206 x 381 x 457	1,9	57
453	<b>CM-16</b>	1219 x 609 x 609	1,5	55





# Hydraulic Wedgie and Spread Cylinders

▼ Shown clockwise from top: WR-13, WR-5, A-92, WR-15

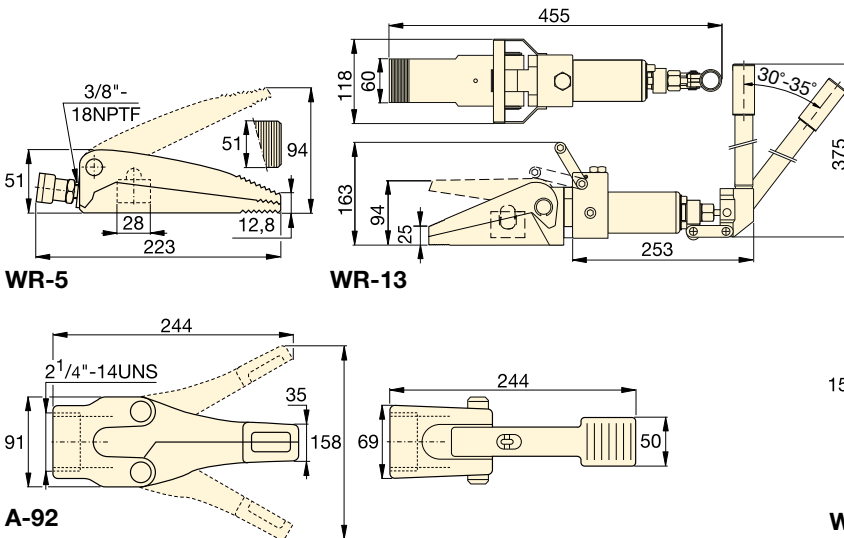

- **WR-5:** For use in very confined work areas
- **WR-13:** Integrated pump offers portable power
- **WR-15:** For long stroke spreading applications
- **Single-acting, spring return**
- **A-92:** Spreader attachment; threads on RC-Series 10 ton cylinders (except RC-101).



Cylinder Capacity ton (kN)	Tip Clearance mm	Model Number	Maximum Spread (mm)	Cylinder Effective Area (cm <sup>2</sup> )	Oil Capacity (cm <sup>3</sup> )	 (kg)
1 (8,9)	12,8	<b>WR-5</b>	94	6,5	10	2,3
1,50 (12)	25,4	<b>WR-13</b>	94	14,4	—	12,0
0,75 (6)	32	<b>WR-15</b>	292	14,5	64	11,3
1 (8,9)	35	<b>A-92</b>	158	—	—	3,6

## A WR Series



Capacity:  
**0,75 - 1,50 ton**

Tip Clearance:  
**12,8 - 35 mm**

Maximum Spread:  
**94 - 292 mm**

Maximum Operating Pressure:  
**700 bar**



**RC-Series Cylinders**  
10 ton RC-Series cylinders (except RC-101) fit into A-92 Spreader Attachment.

Page: 6



**Best Match Hand Pump**  
To power your WR-5 and WR-15 the **P-392** hand pump is an ideal choice. Use Enerpac H700-Series (page 120) for hydraulic connection.

Page: 66

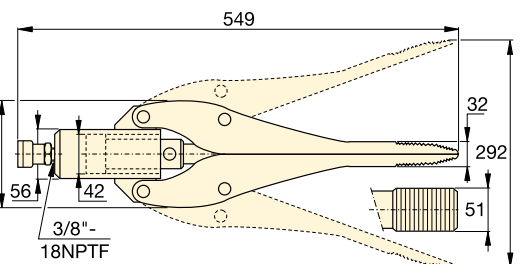



# Hydraulic Cutterheads

▼ Shown from left to right: WHC-4000, WHC-750



- Single-acting, spring return on all models, except WHR-1250
- Guillotine action for easy operation
- Lifting handles on larger models for easy transport
- Carrying bag included for easy carrying and tool protection
- Ideal for use with most Enerpac pumps featuring 3-way valve or dump valve and 700 bar pressure rating (except WHR-1250, which requires 4-way valve)
- CR-400 coupler and dust cap included on all models.

## WHC, WHR, STC Series

Capacity:  
**3 - 20 ton**

Cutting Capacity:  
**12 - 101 mm**

Maximum Operating Pressure:  
**700 bar**

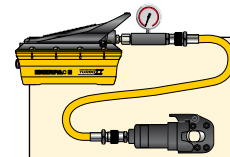

### Tool Sets

Cutterheads marked with an \* are available as sets (pump, tool, gauge, couplers and hose) for your ordering convenience.

Cutterhead Model Nr.	Pump Model Nr.	Set Model Number
WHC-750	P-392	<b>STC-750H</b>
WHC-750	P-392FP	<b>STC-750FP</b>
WHC-750	PATG-1102N	<b>STC-750A</b>
WHC-1250	P-392	<b>STC-1250H</b>
WHC-1250	P-392FP	<b>STC-1250FP</b>
WHC-1250	PATG-1102N	<b>STC-1250A</b>

▼ Steel rope is easily cut with the smooth guillotine action of an Enerpac cutterhead.



### ▼ Selection Chart Maximum Cutting Capacities (ø in mm)

Cutter Head Operation	Capacity	Model Number	Oil Capacity	Length	Steel Wire Rope, Hemp-core or IWRC 6x7 6x12 6x19	Round Bar				Wire Strand			Cable		Replacement Blades		
						Copper Wire or Bar	Aluminum Wire or Bar	Soft Steel Bolts	Reinforcing Bar	Bare Copper Wire Strands	Bare Aluminum Wire Strands	ACSR	Guy Steel Wire Strands	Telephone Cable CPP		Underground Cable (Power)	
Single-Acting	4	<b>WHC-750*</b>	19,7	127	19	19	19	19	12	19	19	19	16	☆	☆	3,2	<b>WCB-750</b>
	20	<b>WHC-1250*</b>	134,4	279	31	28	31	28	25	31	31	31	22	☆	☆	11,3	<b>WCB-1250</b>
	13	<b>WHC-2000</b>	119,6	381	25	31	31	22	☆	50	50	50	19	☆	50	10,4	<b>WCB-2000</b>
	3	<b>WHC-3380</b>	65,5	482	☆	☆	☆	☆	☆	41	42	☆	☆	85	85	9,1	<b>WCB-3380</b>
	8	<b>WHC-4000</b>	137,7	609	☆	☆	☆	☆	☆	☆	☆	☆	☆	101	101	14,5	<b>WCB-4000</b>
Dbl.-Act.	20	<b>WHR-1250</b>	122,9	419	31	31	31	28	25	31	31	31	22	☆	☆	11,8	<b>WCB-1250</b>

\* Available in sets with P-392 Hand Pump, P-392FP Foot Pump or PATG-1102N Turbo Air Pump.

☆ Will not cut designated material

# Self-Contained Hydraulic Cutters

▼ Shown from left to right: **WMC-2000, WMC-750**



- Rotating heads for operator convenience
- Guillotine action for easy operation
- Carrying bag included for easy carrying and tool protection
- Velcro straps to secure handles on larger models for easy carry
- Spring return for easy operation
- Light weight self-contained tool, can be used anywhere.

## WMC Series



Capacity:

**3 - 20 ton**

Cutting Capacity:

**14 - 85 mm**

Maximum Operating Pressure:

**700 bar**



### Replacement Blades

60-62HRC hardened replacement blades.

For Cutter Model Number	Order Blades Model Number
WMC-580	<b>WCB-580</b>
WMC-750	<b>WCB-750</b>
WMC-1000	<b>WCB-1000</b>
WMC-1250	<b>WCB-1250</b>
WMC-1580	<b>WCB-1580</b>
WMC-2000	<b>WCB-2000</b>
WMC-3380	<b>WCB-3380</b>



**CAUTION !:** A "☆" in the charts on these pages means that this hydraulic cutter is not designed to cut this size or type of material. Any attempt to do so may result in personal injury and damage to the unit and will void the warranty.

### ▼ Selection Chart Maximum Cutting Capacities (ø in mm)

Capacity ton	Model Number	Length (mm)	Steel Wire Rope, Hemp-core or IWRC 6x7 6x12 6x19	Round Bar				Wire Strand					Cable		Weight (kg)
				Copper Wire or Bar	Aluminum Wire or Bar	Soft Steel Bolts	Reinforcing Bar	Bare Copper Wire Strands	Bare Aluminum Wire Strands 6x7	ACSR Wire Strands	Guy Steel Wire Strands 1x7	Guy Steel Wire Strands 1x19	Telephone Cable CPP	Underground Cable (Power)	
4	<b>WMC-580</b>	381	16	16	16	16	☆	16	16	16	14	14	☆	16	3,6
4	<b>WMC-750</b>	381	19	17	17	17	☆	19	19	19	14	14	☆	17	3,6
20	<b>WMC-1000*</b>	679	☆	19	19	19	19	☆	☆	☆	☆	☆	☆	☆	11,3
20	<b>WMC-1250</b>	679	31	28	31	31	22	31	31	31	22	25	☆	☆	10,4
6	<b>WMC-1580</b>	558	19	19	19	19	☆	38	41	41	16	16	☆	41	6,8
13	<b>WMC-2000</b>	628	25	31	31	22	☆	50	50	50	19	19	☆	50	10,9
3	<b>WMC-3380</b>	660	☆	☆	☆	☆	☆	46	42	☆	☆	☆	85	85	10,0

\* Cuts 12 mm alloy chain grade 70 (type G7 transport or tie-down) or grade 80 (for overhead lifting applications)

☆ Will not cut designated material

# STB-Series, Pipe Bender Sets

▼ Shown: STB-101H



## Quick, Safe and Wrinkle-free Bending



### 'One Shot' and 'Sweep'





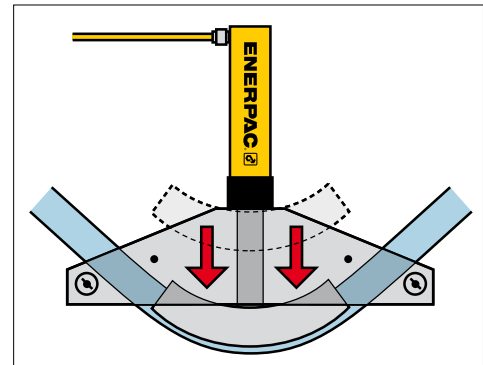



One shot shoes give up to a 90° bend without resetting. Sweep shoes are used where increasing radii are required for multiple parallel pipe installations.

- Makes smooth, wrinkle-free bends
- Sets include genuine Enerpac cylinder, hose and manual, air or electric pump
- Sets are also available without hydraulics
- Bending shoes and bending frame are lightweight, heat-treated aluminium
- All sets include sturdy steel storage case
- All sets include BZ-12091 angle indicator for accurate bending
- BZ-12377 Shoe Lock Pin included in every set
- Eject-O-Matic™ benders (STB-202 models) have double-acting cylinder to eject pipe from the bending shoe.



▲ Typical one shot bending operation.

### ▼ SELECTION CHART

Pipe Range Nominal Size (inch)		Set Model Number	Hand Pump*	Air Pump*	Electric Pump*		Cylinder*	Hose*	Saddle*	 (kg)
One Shot	Sweep									
1/2 - 2	-	STB-101X	-	-	-	-	-	-	A-12	40
		STB-101N	-	-	-	-	RC-1010	HC-7206	A-12	48
		STB-101H	P-392	-	-	-	RC-1010	HC-7206	A-12	52
		STB-101A	-	PATG-1102N	-	-	RC-1010	HC-7206	A-12	54
		STB-101E	-	-	PUJ-1200E <sup>2)</sup>	-	RC-1010	HC-7206	A-12	57
1 - 2	2 1/2 - 4	STB-221X	-	-	-	-	-	-	A-29	104
		STB-221N	-	-	-	-	RC-2510	HC-7206	A-29	119
		STB-221H	P-80	-	-	-	RC-2510	HC-7206	A-29	130
1 1/4 - 4	-	STB-202X <sup>1)</sup>	-	-	-	-	-	-	A-29	143
		STB-202N <sup>1)</sup>	-	-	-	-	RR-3014	HC-7206 (2x)	A-29	174
		STB-202E <sup>1)</sup>	-	-	-	ZU4408SE <sup>2)</sup>	RR-3014	HC-7206 (2x)	A-29	212

\* See corresponding sections in this catalog for more detailed specifications.

<sup>1)</sup> Eject-O-Matic™ <sup>2)</sup> For 115 volt applications replace the last digit of Set Model Number and pump from 'E' to 'B'.



# Pipe Bender Sets

Nominal Pipe Size (inch)	Wall Thickness (mm)	Schedule Pipe *	Pipe Bend Inside Radius (inch)	STB-101	STB-221	STB-202	One Shot Bending Shoe Model Number	Sweep Bending Shoe Model Number
				ø 1/2" - 2" One Shot	ø 1 - 2" One Shot ø 2 1/4" - 4" Sweep	ø 1 1/4" - 4" One Shot		
1/2	2,8	40	2 7/8	Yes	Yes	WS	BZ-12011	-
	3,7	80		Yes	Yes	WS		
	4,7	160		WS	WS	WS		
	7,5	DEH		WS	WS	WS		
3/4	2,9	40	4	Yes	Yes	WS	BZ-12021	-
	3,9	80		Yes	Yes	WS		
	5,5	160		WS	WS	WS		
	7,8	DEH		WS	WS	WS		
1	3,4	40	5 1/8	Yes	Yes	WS	BZ-12031	-
	4,5	80		Yes	Yes	WS		
	6,4	160		WS	WS	WS		
	9,1	DEH		-	WS	WS		
1 1/4	3,6	40	6 7/16	Yes	Yes	Yes	BZ-12041	-
	4,9	80		Yes	Yes	Yes		
	6,4	160		WS	WS	Yes		
	8,7	DEH		-	WS	WS		
1 1/2	3,7	40	7 5/16	Yes	Yes	Yes	BZ-12051	-
	5,1	80		Yes	Yes	Yes		
	7,1	160		WS	WS	Yes		
	10,2	DEH		-	WS	WS		
2	3,9	40	8 5/16	Yes	Yes	Yes	BZ-12061	-
	5,5	80		Yes	Yes	Yes		
	8,7	160		-	WS	Yes		
2 1/2	5,2	40	9 1/2	-	Yes	Yes	BZ-12341	BZ-12382
	7,0	80		-	WS	Yes		
	9,5	160		-	WS	Yes		
3	5,5	40	11 1/4	-	Yes	Yes	BZ-12351	BZ-12383
	7,6	80		-	WS	Yes		
3 1/2	5,7	40	15 1/2	-	Yes	Yes	BZ-12391	BZ-12384
	8,1	80		-	WS	Yes		
4	6,0	40	17 3/4	-	Yes	Yes	BZ-12392	BZ-12385
	8,6	80		-	-	Yes		

\*Schedule Pipe: 40 = Standard; 80 = Extra Heavy; 160 = Double Extra Heavy;  
DEH = Double Extra Heavy (slightly thicker than 160);  
WS = Can be bent using wider spacing for swivel shoes.

## STB Series



Nominal Pipe Size:

**1/2 - 4 inch**

Maximum Bending:

**90°**

Maximum Operating Pressure:

**700 bar**

▼ Steel pipe is quickly and safely bent up to 90° using the STB-101H Pipe Bender Set.



Frame Assembly	Pivot Pin	Pivot Shoes	Bending Shoes included (Shoes with <sup>3)</sup> are Sweep, all other shoes are One Shot)								Set Model Number
BZ-12371	BZ-12375	BZ-12071	BZ-12011	BZ-12021	BZ-12031	BZ-12041	BZ-12051	BZ-12061	-	-	STB-101X
											STB-101N
											STB-101H
											STB-101A
											STB-101E
BZ-12372	BZ-12376	BZ-13401	BZ-12031	BZ-12041	BZ-12051	BZ-12061	BZ-12382 <sup>3)</sup>	BZ-12383 <sup>3)</sup>	BZ-12384 <sup>3)</sup>	BZ-12385 <sup>3)</sup>	STB-221X
											STB-221N
											STB-221H
BZ-12374	BZ-12376	BZ-13401	-	BZ-12041	BZ-12051	BZ-12061	BZ-12341	BZ-12351	BZ-12391	BZ-12392	STB-202X <sup>1)</sup>
											STB-202N <sup>1)</sup>
											STB-202E <sup>1)</sup>



▼ Shown: PTJ5S and 5DA1



## Field-proven Tools for Mono-Strand Tensioning



### SCJ Short Cable Jack

For pulling applications where the tendons are shortened, the SCJ Jack only requires 100 mm of exposed cable. Uses standard 216 mm stroke single-acting cylinders, other strokes available upon request.

Contact Enerpac for details.



### ZU4-Series Electric Pumps

Specifically designed to operate with the most popular lines of stressing jacks, the ZU4-Series Pumps have the features, performance and options that are required for use in post-tensioning markets.

- Durable, field-proven designs, with “soft-grip” ergonomic handles reduce operator fatigue
- Single-acting *PTJ* models, with spring-seating and optional power-seating are equipped with the new Enerpac *RC* Post-tensioning cylinders with a 254 mm stroke, ideal for slab-on-grade applications
- Double-acting *DA* models have an 216 mm stroke and are machined from a steel billet; feature standard power-seating and “gun-drilled” internal hydraulic passages
- All jacks have a standard 3" nose assembly. Longer nose assemblies are available as accessories for all models
- A full line of grippers is available to tension common strand diameters
- Complete offering of Enerpac parts and soft kits allow quick and easy service.

Page:  86

### ▼ SELECTION CHART

Tool Capacity ton (kN)	Seater Type	Strand Diameter Standard (inch)	Model Number	Tool Operation**		Stroke (mm)	Oil Capacity (cm <sup>3</sup> )	Tool Effective Area (cm <sup>2</sup> )	Max. Pressure (bar)	 (kg)
				S/A	D/A					
20 (201)	Spring	.50 - .52	PTJ5S	•	-	254	743	28,9	700	25
20 (201)	Power (hydr.)	.50 - .52	PTJ5P	•	-	254	743	28,9	700	25
20 (201)	Power (hydr.)	.50 - .52	5DA1-AL	-	•	216	869	40,5	450	16
20 (201)	Power (hydr.)	.50 - .52	5DA1	-	•	216	869	40,5	450	19
20 (201)	*	.50 - .52	SCJ	•	-	254	743	28,9	700	22
30 (295)	Spring	.60 - .62	PTJ6S	•	-	254	1029	40,5	700	35
30 (295)	Power (hydr.)	.60 - .62	PTJ6P	•	-	254	1029	40,5	700	35
26 (231)	Power (hydr.)	.60 - .62	6DA1	-	•	216	1108	51,3	450	24

\* SCJ is a short-pull jack, there is no seating device.

\*\* S/A = single-acting; D/A = double-acting.

# Mono-Strand Stressing Tools

## Mono-Strand Tensioning Tool Operational Sequence

The sequence of operation of the double-acting **5DA1** tool is illustrated. Single-acting, spring-seat models are similar.

Installation    Pulling Tendon    Seating Wedge    Retraction

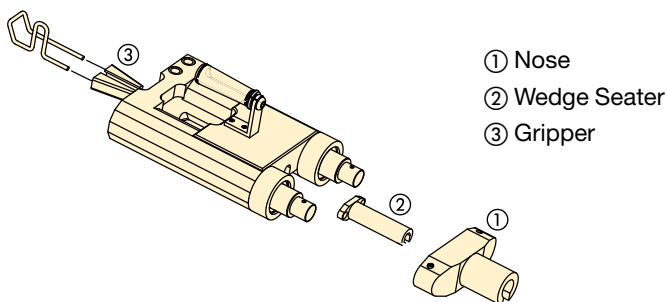
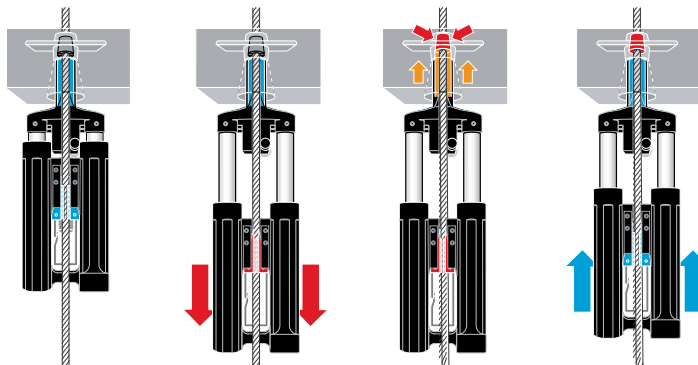

Dimensions (mm)			
Model No.	A	B	C
PTJ5	533	229	165
PTJ6	559	259	178
SCJ	470	216	165
5DA1	470	191	165
6DA1	470	216	165

3/8" NPTF ports; PTJ and DA power seat models include FZ-1055 fitting.

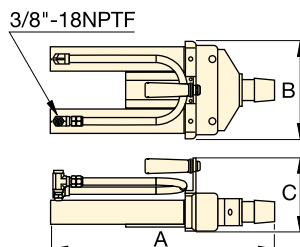

**PTJ  
5DA  
SCJ  
Series**



Capacity:  
**20 - 30 ton**

Stroke:  
**216 - 254 mm**

Strand Diameters:  
**12,7 - 15,7 mm**

Maximum Operating Pressure:  
**450 - 700 bar**



### Multi-Strand Stressing Jacks

For applications requiring multi-strand tensioning jacks, contact Enerpac Integrated Solutions at:

[integratedsolutions@enerpac.com](mailto:integratedsolutions@enerpac.com)

Page: 228

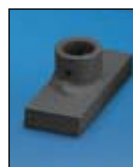

### Jack Feet

Two required per jack. Used in place of a nose to react on either side of wedge pocket.

Model Number	Used with Jack
402000	5DA1
403325	6DA1

## ▼ Optional and Replacement Accessories Selection Chart

Nose		Wedge Seater		Gripper Set Diameter								Used with Jack	
76 mm	152 mm	76 mm	152 mm	9,7 mm	10,9 mm	12,7 mm	15,7 mm	4 mm	5 mm	6 mm	7 mm		
												PTJ5S	
400740*	401180	305340*	401200	400900	400880	400850*	-	400930	400940	400950	400960		PTJ5D
401520*	401840	305360*	305365	401652	401655	401660*	-	-	401670	-	-		5DA1-AL
401520*	401840	305360*	305365	401652	401655	401660*	-	-	401670	-	-		5DA1
-	-	-	-	-	-	-	-	-	-	-	-		SCJ
400740*	401180	305340*	401200	400900	400880	400850	400980*	400930	400940	400950	400960	PTJ6S	
400740*	401180	305340*	401200	400900	400880	400850	400980*	400930	400940	400950	400960	PTJ6P	
403180*	403220	403140*	403165	400988	-	400986	400990*	-	-	-	-	6DA1	

\* Shipped with tool.

**ENERPAC's Bolting Solutions cater to the complete bolting work-flow, ensuring joint integrity in a variety of applications throughout the industry:**

### Joint Assembly

From simple pipe alignment to complex joint positioning of large structural assemblies, our comprehensive line of joint assembly products range from hydraulic and mechanical alignment tools to PLC-controlled multi-point positioning systems.

### Controlled Tightening

Enerpac offers a variety of controlled tightening options to best meet the requirements of your application. From mechanical torque multipliers to hydraulically driven square drive wrenches and from low profile torque wrenches to inter-connectable bolt tensioning tools; we offer the products you need for accurate and simultaneous tightening of multiple bolts.

### Joint Separation

Enerpac also provides hydraulic nut splitters and a variety of mechanical and hydraulic spreading tools for joint separation during inspection, maintenance and decommissioning operations.

High quality bolting solutions from the brand you can trust. See how Enerpac can make your bolting work-flow more accurate, safer and efficient.



### Bolting Integrity Software

Visit [www.enerpac.com](http://www.enerpac.com) to access our free on-line bolting software application and obtain information on tool selection, bolt load calculations and tool pressure settings. A combined application data sheet and joint completion report is also available.

















### Torque Tightening

See our 'Yellow Pages' for information on torque tightening.

Page: **252**



# Bolting Tools & Pumps Section Overview

	Capacity	Tool type and functions	Series		Page
Controlled Tightening and Loosening	1015 - 10.845 Nm 750 - 8000 Ft.lbs	<b>Manual Torque Multipliers</b>	E		186 ▶
	1898 - 34.079 Nm 1400 - 25.140 Ft.lbs	<b>Square Drive Hydraulic Torque Wrenches</b> Rigid steel design & maximum versatility	S		188 ▶
	19 - 155 mm 3/4 - 6 1/8 inch	<b>Heavy-Duty Impact Sockets</b> Square drive	BSH		192 ▶
	2712 - 20.337 Nm 2000 - 15.000 Ft.lbs	<b>Hexagon Hydraulic Torque Wrenches</b> Rigid steel design & low profile	W		194 ▶
		<b>Selection Matrix</b> Torque Wrenches - Pumps - Hoses			202 ▶
	Flow: 0,34 l/min Power: 0,37 kW	<b>Portable Electric Torque Wrench Pumps</b> Compact Economy	PMU		203 ▶
	Flow: 0,90 l/min Power: 1,25 kW	<b>Portable Electric Torque Wrench Pumps</b> Z-Class innovation	ZU4T		204 ▶
	Flow: 0,82-1,64 l/min Power: 1,1 - 2,2 kW	<b>Electric Torque Wrench Pumps</b> Z-Class innovation	ZE4T ZE5T		208 ▶
	Flow: 0,33 l/min Air: 1130 l/min	<b>Air Driven Torque Wrench Pumps</b> Portable and Compact	PTA		210 ▶
	Flow: 0,90 l/min Air: 2840 l/min	<b>Air Driven Torque Wrench Pumps</b> Z-Class innovation	ZA4T		212 ▶
Joint Assembly and Joint Separation	0,3 - 0,5 ton (3 - 45 kN)	<b>Flange Alignment Tools</b> Mechanical and Hydraulic	ATM		216 ▶
	8 - 14 ton (72 - 125 kN)	<b>Step-type Industrial Spreaders</b> Mechanical and Hydraulic	FSH FSM		217 ▶
	5 - 10 ton (45 - 101 kN)	<b>Pin-type Hydraulic Flange Spreaders</b>	FS		218 ▶
	10 - 75 mm hex. 70 - 130 mm hex.	<b>Hydraulic Nut Cutters</b> <b>Hydraulic Nut Splitters</b>	NC NS		219 ▶ 220 ▶



# E-Series, Manual Torque Multipliers

▼ Shown from left to right: E291, E393, E494



- High-efficiency planetary gear sets achieve high output torque from low input torque
- Operator protected by anti-backlash device
- Torque multiplier accuracy  $\pm 5\%$
- Reversible, tighten or loosen bolts
- Reaction bar or reaction plate style
- Angle-of-turn protractor standard on E300-Series models
- Reaction plate models offer increased versatility with reaction point locations
- E300 and E400-Series have replaceable shear drives, providing overload protection of internal power train
- One replacement shear drive is included with each E300 and E400-Series models.



◀ Enerpac Reaction Bar Torque Multiplier E393 used to manually torque bolts up to 4300 Nm.

## Accurate, Efficient Torque Multiplication

When accurate make-up or break-out of stubborn fasteners requires high torque



### Typical Torque Multiplier Applications

- Locomotives
- Power plants
- Pulp and paper mills
- Refineries
- Chemical plants
- Mining and construction
- Off-road equipment
- Shipyards
- Cranes.



### MTW-250 Manual Torque Wrench

Available to power manual torque multipliers.

Technical information:

- 1/2" Square Drive
- 60-330 Nm (45-250 Ft.lbs)

### ▼ SELECTION CHART

Torque Multiplier Type	Output Torque Capacity		Model Number
	(Nm)	(Ft.lbs)	
Reaction Bar Multiplier	1015	750	E290PLUS
	1355	1000	E291
	1625	1200	E391
	2980	2200	E392
	4340	3200	E393
Reaction Plate Multiplier	2980	2200	E492
	4340	3200	E493
	6780	5000	E494
	10845	8000	E495

# Manual Torque Multipliers



## Manual Torque Multipliers

Enerpac manual torque multipliers provide efficient torque multiplication in wide clearance applications and when external power sources are not available.

Manual torque multipliers are used in most industrial, construction, and equipment maintenance applications. Hydraulic torque wrenches are better suited for tight tolerance, flange and repetitious bolting applications.

## Use Reaction Bar Models:

- where space is limited,
- where multiple reaction points are available,
- when portability is desirable.

## Use Reaction Plate Models:

- above 4300 Nm output torque,
- on flanges and applications where neighbouring bolt or nut is available to react against
- when extreme reaction forces are generated.

## E Series



Maximum Output Torque:

**1015 - 10.845 Nm**

Torque Ratio:

**3,3:1 - 52:1**

Output Ratio Accuracy:

**± 5 %**

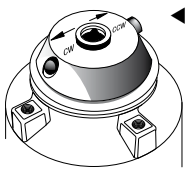

### Selector Pawl

Models with anti-backlash protection have directional selector pawls. Set the pawl for clockwise or counter-clockwise rotation.

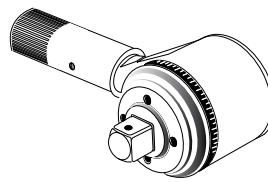

### Angle-of-Turn Protractor

E391, E392 and E393 models include an angle-of-turn protractor (scale) to tighten fasteners using a "torque turn" method. Allows accurate measuring a specific number of degrees of rotation.

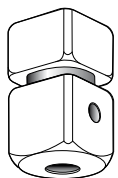

### Shearable Square Drive

Provides overload protection on E300- and E400-series multiplier's power train by shearing at 103-110% of rated capacity. Internal shear pin prevents tool from falling off bolt.



### CAUTION!

Never use impact air tools for power driving torque multipliers. Torque multiplier drive train damage will occur.



### Hydraulic Torque Wrenches

Enerpac offers a complete range of square drive and hexagon cassette torque wrenches.

Page: 188

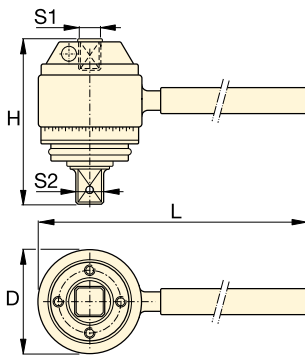

Reaction Bar Type <sup>1)</sup>

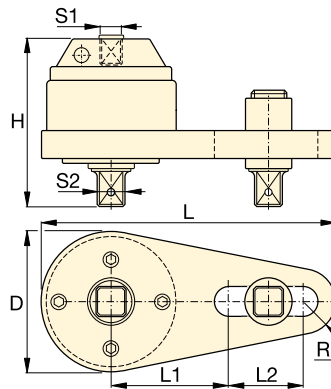

Reaction Plate Type <sup>1)</sup>



### BSH-Series Sockets

Heavy-Duty Impact Sockets for power driven torquing equipment.

Page: 192

Input Torque <sup>2)</sup>	Torque Ratio	Input Female Square Drive S1 (inch)	Output Male Square Drive		Over-load protection	Anti-Back-lash	Dimensions (mm)						Model Number	
			S2 (inch)	Replaceable Shear Drive Model Nr.			D	H	L	L1	L2	R		
308 (Nm)   227 (Ft.lbs)	3,3 : 1	1/2	3/4	–	No	No	71	84	218	–	–	–	1,8 (kg)	<b>E290PLUS</b>
411 (Nm)   303 (Ft.lbs)	3,3 : 1	1/2	3/4	–	No	No	71	84	442	–	–	–	2,5 (kg)	<b>E291</b>
271 (Nm)   200 (Ft.lbs)	6 : 1	1/2	3/4	E391SDK	Yes	No	100	102	498	–	–	–	4,1 (kg)	<b>E391</b>
219 (Nm)   162 (Ft.lbs)	13,6 : 1	1/2	1	E392SDK	Yes	Yes	103	146	498	–	–	–	6,9 (kg)	<b>E392</b>
234 (Nm)   173 (Ft.lbs)	18,5 : 1	1/2	1	E393SDK	Yes	Yes	103	165	498	–	–	–	8,3 (kg)	<b>E393</b>
219 (Nm)   162 (Ft.lbs)	13,6 : 1	1/2	1	E392SDK	Yes	Yes	124	140	356	140	124	32	7,8 (kg)	<b>E492</b>
234 (Nm)   173 (Ft.lbs)	18,5 : 1	1/2	1	E393SDK	Yes	Yes	124	163	356	140	124	32	8,8 (kg)	<b>E493</b>
256 (Nm)   189 (Ft.lbs)	26,5 : 1	1/2	1 1/2	E494SDK	Yes	Yes	143	222	378	178	89	42	15,4 (kg)	<b>E494</b>
208 (Nm)   154 (Ft.lbs)	52 : 1	1/2	1 1/2	E495SDK	Yes	Yes	148	273	386	178	89	48	22,8 (kg)	<b>E495</b>

<sup>1)</sup> E200 and E400-series do not have an Angle-of-Turn Protractor (scale).

<sup>2)</sup> User must verify manual torque wrench accuracy prior to use to ensure accurate final output torque.

▼ From left to right: S3000, S6000, S1500



## Rigid Steel Design

## The *Professional* Square Drive Solution



### S-Series, Square Drive Wrenches

This product range has been designed using state-of-the-art CAD techniques to bring you the most advanced square drive torque wrench on the market.

To ensure that the tools you buy meet our own exacting requirements, during the design process every prototype was put through finite element stress analysis, photo-elastic modelling, rigorous cyclic testing and strain gauging.

### Simplicity

- 360° click-on, multi-position reaction arm
- Push button square drive release to quickly reverse the square drive for tightening or loosening
- Fine tooth ratchet prevents tool “lock-on”
- Single 360° hydraulic swivel manifold, complete with screw lock couplings, increases wrench and hose manoeuvrability.

### Design

- Compact, high strength uni-body construction for a small operating radius
- Robust design with minimal parts enables easy on-site maintenance without special tools
- Lightweight, ergonomic design for easy handling and an easy fit, even in applications where access is limited
- Optimised strength-to-weight ratio
- Fast operation due to the large nut rotation per wrench cycle (35 degree rotation angle) and rapid return stroke.

### Reliability

- All wrenches are nickel-plated for excellent corrosion protection and improved durability in harsh environments.

### Accuracy

- Constant torque output provides high accuracy across the full stroke
- Uni-body construction ensures accuracy by reducing internal deflections.



### TSP - Pro Series Swivel

Featuring Tilt & Swivel technology the TSP provides 360° X-axis rotation and 160° Y-axis rotation.

#### How to Order:

Order as an accessory which can be fitted to existing S-Series wrenches.

Factory fitted to new S-Series wrenches: Add suffix “P” to the torque wrench model number. Example: **S1500-P**.

Page: 191



### Torque Wrench Hoses

Use Enerpac THQ-700 Series torque wrench hoses with S-Series torque wrenches to ensure the integrity of your

hydraulic system.

6 m long, 2 hoses	<b>THQ-706T</b>
12 m long, 2 hoses	<b>THQ-712T</b>

# Double-acting Square Drive Hydraulic Torque Wrenches

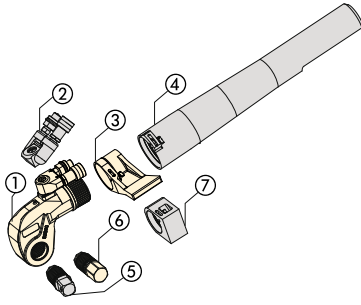

- ① Drive Unit
- ② Pro Series Swivel (page 191)
- ③ Reaction Arm (page 191)
- ④ Extended Reaction Arm (page 191)
- ⑤ Square Drive
- ⑥ Allen Drive (page 190)
- ⑦ Short Reaction Arm (page 190)



## Use only Heavy Duty Impact Sockets

For power driven torquing equipment, according to ISO2725 and ISO1174;

DIN 3129 and DIN 3121 or ASME-B107.2/1995.

Page: 192

## S Series



Maximum Torque at 700 bar:

**34.079 Nm**

Square Drive Range:

**3/4 - 2 1/2 inch**

Nose Radius:

**25,0 - 63,5 mm**

Maximum Operating Pressure:

**700 bar**

### TORQUE WRENCH SELECTION (based on socket size range <sup>1)</sup>)

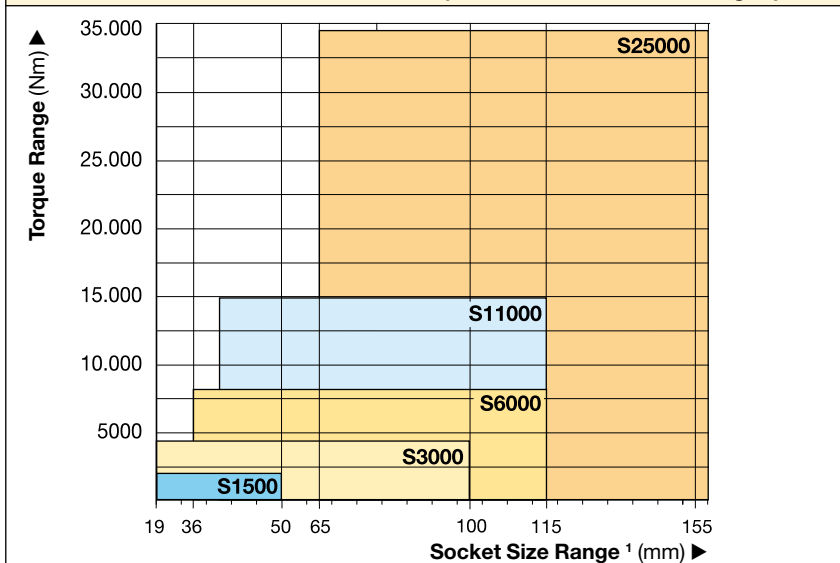

<sup>1)</sup> See page 254 for table of hexagon sizes of bolts, nuts and related thread diameters.



### Torque Wrench Pump Selection Matrix

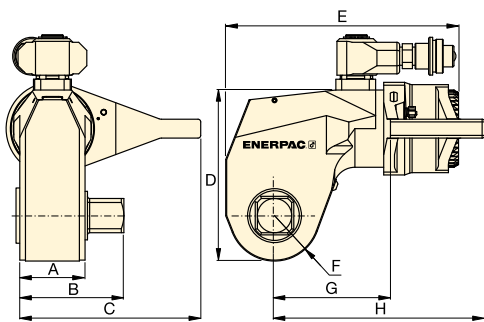

For optimum speed and performance see the torque wrench and pump matrix.

Page: 202



The rigid steel design of S-Series torque wrenches guarantee durability, reliability and safety. These wrenches can be powered by the portable ZU4T-Series pumps.



Maximum Torque at 700 bar		Square Drive		Torque Wrench Model Number *	Dimensions (mm)								(kg)	
		Size (inch)	Model Nr. (included with wrench)		A	B	C	D	E	F	G	H		
(Nm)	(Ft.lbs)													
1898	1400	3/4	SD15-012	<b>S1500</b>	39	63	110	95	136	25,0	69	119	2,7	
4339	3200	1	SD30-100	<b>S3000</b>	48	77	134	126	172	33,0	90	159	5,0	
8144	6010	1 1/2	SD60-108	<b>S6000</b>	57	90	179	162	201	42,0	112	187	8,5	
14.914	11.000	1 1/2	SD110-108	<b>S11000</b>	71	111	196	185	226	49,5	132	227	15,0	
34.079	25.140	2 1/2	SD250-208	<b>S25000</b>	87	143	244	240	292	63,5	182	292	31,0	

See "Yellow Pages" section for torque conversions.

\* To order a S-series wrench fitted with the TSP swivel, add suffix "P" to the model number. Example: **S1500-P**.



# SDA-Series, Allen Drives

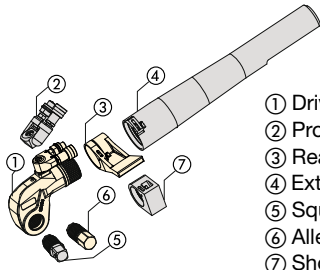

- ① Drive Unit
- ② Pro Series Swivel
- ③ Reaction Arm
- ④ Extended Reaction Arm
- ⑤ Square Drive
- ⑥ Allen Drive
- ⑦ Short Reaction Arm

Maximum Torque at 700 bar:

**34.079 Nm**

Hexagon Size Allen Drive:



**1/2 - 2 1/4 inch**

Hexagon Size Allen Drive:

**14 - 85 mm**

**For  
S  
Series**



Torque Wrench	Optional Allen Drives, Imperial				Optional Allen Drives, Metric				Short Reaction Arm for Allen Drives			
	Model Number	Hexagon Size <sup>1)</sup> (inch)	Maximum Torque (Nm)	Model Number	Dim. B1 (mm)	Hexagon Size <sup>1)</sup> (mm)	Maximum Torque (Nm)	Model Number	Dim. B1 (mm)	Model Number	Dimensions (mm) C1   H1	
 <b>S1500</b> (1898 Nm)		1/2	481	SDA15-008	66	14	644	SDA15-14	66	 <b>SRA15</b>	67,5	65
		5/8	935	SDA15-010	67	17	1152	SDA15-17	68			
		3/4	1619	SDA15-012	71	19	1606	SDA15-19	70			
		7/8	1897	SDA15-014	74	22	1897	SDA15-22	73			
		1	1897	SDA15-100	77	24	1897	SDA15-24	74			
<b>S3000</b> (4339 Nm)		5/8	935	SDA30-010	77	17	1152	SDA30-17	77	<b>SRA30</b>	80,0	74
		3/4	1619	SDA30-012	80	19	1606	SDA30-19	79			
		7/8	2568	SDA30-014	83	22	2486	SDA30-22	82			
		1	3828	SDA30-100	86	24	3232	SDA30-24	84			
		1 1/8	4336	SDA30-102	88	27	4336	SDA30-27	85			
		1 1/4	4336	SDA30-104	89	30	4336	SDA30-30	87			
		-	-	-	-	32	4336	SDA30-32	88			
<b>S6000</b> (8144 Nm)		5/8	935	SDA60-010	85	17	1152	SDA60-17	86	<b>SRA60</b>	91,5	89
		3/4	1619	SDA60-012	89	19	1606	SDA60-19	88			
		7/8	2568	SDA60-014	92	22	2486	SDA60-22	91			
		1	3828	SDA60-100	95	24	3232	SDA60-24	93			
		1 1/8	5454	SDA60-102	97	27	4600	SDA60-27	94			
		1 1/4	7480	SDA60-104	98	30	6308	SDA60-30	96			
		-	-	-	-	32	7656	SDA60-32	97			
<b>S11000</b> (14.911 Nm)		1 1/4	7480	SDA110-104	115	30	6308	SDA110-30	112	<b>SRA110</b>	127,5	106
		1 3/8	9953	SDA110-106	117	32	7656	SDA110-32	114			
		1 1/2	12.920	SDA110-108	118	36	10.894	SDA110-36	117			
		1 5/8	14.905	SDA110-110	122	41	14.905	SDA110-41	121			
		1 3/4	14.905	SDA110-112	125	46	14.905	SDA110-46	127			
<b>S25000</b> (34.079 Nm)		1 1/2	12.920	SDA250-108	141	36	10.894	SDA250-36	140	<b>SRA250</b>	158,5	135
		1 5/8	16.423	SDA250-110	145	41	16.098	SDA250-41	144			
		1 3/4	20.508	SDA250-112	148	46	22.730	SDA250-46	148			
		1 7/8	25.230	SDA250-114	149	50	29.194	SDA250-50	151			
		2	30.617	SDA250-200	151	55	34.079	SDA250-55	154			
		2 1/4	34.079	SDA250-204	154	60	34.079	SDA250-60	158			
		-	-	-	-	65	34.079	SDA250-65	161			
		-	-	-	-	70	34.079	SDA250-70	164			
		-	-	-	-	75	34.079	SDA250-75	168			
		-	-	-	-	85	34.079	SDA250-85	175			

<sup>1)</sup> See page 254 for table of hexagon sizes of bolts, nuts and related thread diameters.

# Accessories for S-Series Torque Wrenches

## TSP-Series, Pro Series Swivels

- Featuring Tilt and Swivel technology
- 360° X-axis and 160° Y-axis rotation
- Increases tool fit in restricted access areas
- Simplifies hose placement.

**TSP  
RTE  
SRS  
Series**

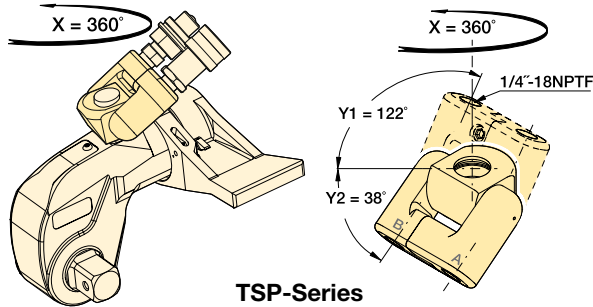

TSP-Series

For Torque Wrench Model Number	Model Number	Maximum Pressure (bar)	 (kg)
S1500, S3000	<b>TSP100</b>	700	0,2
S6000, S11000, S25000	<b>TSP200</b>	700	0,2

To order an S-series wrench fitted with the TSP swivel, add suffix "P" to the model number. Example: **S1500-P**.

## RTE-Series, Reaction Tube Extensions

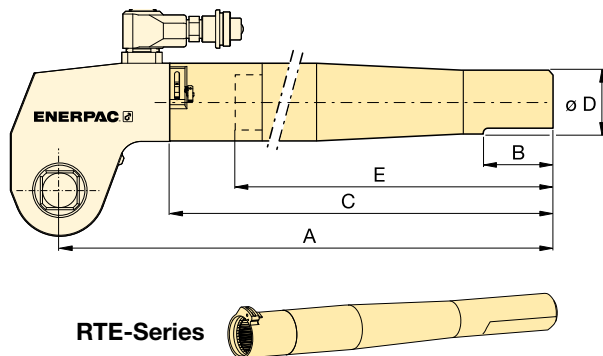

RTE-Series

- Full torque rated
- Increases tool fit in restricted access areas.

For Torque Wrench Model Number	Model Number	Dimensions (mm)					 (kg)*
		A	B	C	D	E	
S1500	<b>RTE15</b>	706	152	636	58	600	4,6
S3000	<b>RTE30</b>	733	152	647	57	600	5,5
S6000	<b>RTE60</b>	747	152	659	65	600	7,7
S11000	<b>RTE110</b>	769	152	675	76	600	11,2
S25000	<b>RTE250</b>	813	152	685	100	600	17,3

\* Weights indicated are for the accessories only and do not include the wrench.

## SRS-Series, Extended Reaction Arms

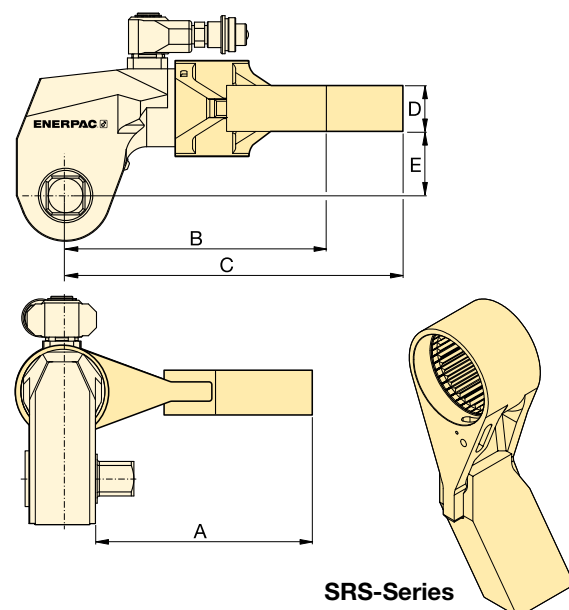

SRS-Series

- Lightweight interchangeable design.

For Wrench Model	Max. Torque (Nm)	Model Number	Dimensions (mm)					 (kg)*
			A	B	C	D	E	
S1500	1800	<b>SRS151</b>	97	87	128	24	34	0,8
	1640	<b>SRS152</b>	122	98	139	24	34	1,0
	1533	<b>SRS153</b>	147	109	150	24	34	1,2
S3000	3918	<b>SRS301</b>	111	104	170	34	48	1,6
	3712	<b>SRS302</b>	137	119	185	34	48	2,0
	3574	<b>SRS303</b>	162	133	200	34	48	2,5
S6000	7842	<b>SRS601</b>	148	134	198	39	62	2,3
	7454	<b>SRS602</b>	173	149	213	39	62	2,7
	7175	<b>SRS603</b>	198	163	228	39	62	3,4
S11000	14650	<b>SRS1101</b>	151	158	233	46	76	4,4
	13957	<b>SRS1102</b>	176	173	248	46	76	5,1
	13391	<b>SRS1103</b>	201	187	262	46	76	5,8
S25000	33538	<b>SRS2501</b>	183	225	314	50	100	7,6
	32049	<b>SRS2502</b>	208	240	329	50	100	8,4
	30750	<b>SRS2503</b>	233	254	344	50	100	10,0

\* Weights indicated are for the accessories only and do not include the wrench.

# BSH-Series, Heavy-Duty Sockets

- Heavy-duty impact sockets
- Supplied with "Pin and Ring"

## METRIC SOCKETS

3/4" Square Drive		1" Square Drive		1 1/2" Square Drive		2 1/2" Square Drive	
Model Number	A/F (mm)	Model Number	A/F (mm)	Model Number	A/F (mm)	Model Number	A/F (mm)
BSH7519	19	BSH1019	19	BSH1536	36	BSH2565	65
BSH7524	24	BSH1024	24	BSH15163	41	BSH2570	70
BSH7527	27	BSH1027	27	BSH1546	46	BSH2575	75
BSH7530	30	BSH1030	30	BSH1550	50	BSH2580	80
BSH7532	32	BSH1032	32	BSH1555	55	BSH2585	85
BSH7536	36	BSH1036	36	BSH1560	60	BSH2590	90
BSH75163	41	BSH10163	41	BSH1565	65	BSH2595	95
BSH7546	46	BSH1046	46	BSH1570	70	BSH25100	100
BSH7550	50	BSH1050	50	BSH1575	75	BSH25105	105
-	-	BSH1055	55	BSH1580	80	BSH25110	110
-	-	BSH1060	60	BSH1585	85	BSH25115	115
-	-	BSH1065	65	BSH1590	90	BSH25120	120
-	-	BSH1070	70	BSH1595	95	BSH25125	125
-	-	BSH1075	75	BSH15100	100	BSH25135	135
-	-	BSH1080	80	BSH15105	105	BSH25140	140
-	-	BSH1085	85	BSH15110	110	BSH25145	145
-	-	BSH1090	90	BSH15115	115	BSH25150	150
-	-	BSH1095	95	-	-	BSH25155	155
-	-	BSH10100	100	-	-	-	-

## BSH Series



Hexagon Size:

**19 - 155 mm | 3/4" - 6 1/8"**



### Select the Right Torque

Choose your Enerpac Torque Wrench using the untightening rule of thumb: Loosening torque equals about 250% of tightening torque.

Page: 252

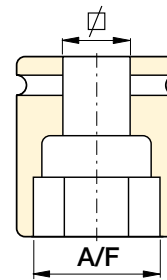

### Hexagon Bolt and Nut Sizes

See the table of hexagon sizes of bolts, nuts and related thread diameters.

Page: 254

## IMPERIAL SOCKETS

3/4" Square Drive		1" Square Drive		1 1/2" Square Drive		1 1/2" Square Drive		2 1/2" Square Drive		2 1/2" Square Drive			
Model Number	A/F (inch)	Model Number	A/F (inch)	Model Number	A/F (inch)	Model Number	A/F (inch)	Model Number	A/F (inch)	Model Number	A/F (inch)		
BSH7519	3/4"	BSH1019	3/4"	BSH10231	2 5/16"	BSH15144	1 7/16"	BSH15281	2 13/16"	BSH25244	2 7/16"	BSH25419	4 13/16"
BSH75088	7/8"	BSH10088	7/8"	BSH10238	2 3/8"	BSH1538	1 1/2"	BSH15288	2 7/8"	BSH25250	2 1/2"	BSH25425	4 1/4"
BSH75094	15/16"	BSH10094	15/16"	BSH10244	2 7/16"	BSH15156	1 9/16"	BSH1575	2 15/16"	BSH2565	2 13/16"	BSH25110	4 5/16"
BSH7527	1 1/16"	BSH1027	1 1/16"	BSH10250	2 1/2"	BSH15163	1 5/8"	BSH15300	3"	BSH25263	2 5/8"	BSH25438	4 3/8"
BSH7530	1 3/16"	BSH1030	1 3/16"	BSH1065	2 9/16"	BSH1543	1 11/16"	BSH15306	3 1/16"	BSH25269	2 11/16"	BSH25450	4 1/2"
BSH75125	1 1/4"	BSH10125	1 1/4"	BSH10263	2 5/8"	BSH15175	1 3/4"	BSH15313	3 1/8"	BSH2570	2 3/4"	BSH25463	4 5/8"
BSH75131	1 5/16"	BSH10131	1 5/16"	BSH10269	2 11/16"	BSH1546	1 13/16"	BSH15319	3 3/16"	BSH25281	2 11/16"	BSH25475	4 3/4"
BSH7535	1 3/8"	BSH1035	1 3/8"	BSH1070	2 3/4"	BSH15188	1 7/8"	BSH15325	3 1/4"	BSH25288	2 7/8"	BSH25488	4 7/8"
BSH75144	1 7/16"	BSH10144	1 7/16"	BSH10281	2 13/16"	BSH15194	1 15/16"	BSH15338	3 3/8"	BSH2575	2 15/16"	BSH25500	5"
BSH7538	1 1/2"	BSH1038	1 1/2"	BSH10288	2 7/8"	BSH15200	2"	BSH15350	3 1/2"	BSH25300	3"	BSH25513	5 1/8"
BSH75156	1 9/16"	BSH10156	1 9/16"	BSH1075	2 15/16"	BSH15206	2 1/16"	BSH15363	3 5/8"	BSH25306	3 1/16"	BSH25519	5 3/16"
BSH75163	1 5/8"	BSH10163	1 5/8"	BSH10300	3"	BSH15213	2 1/8"	BSH1595	3 3/4"	BSH25313	3 1/8"	BSH25525	5 1/4"
BSH7543	1 11/16"	BSH1043	1 11/16"	BSH10306	3 1/16"	BSH15219	2 3/16"	BSH15388	3 7/8"	BSH25319	3 3/16"	BSH25538	5 3/8"
BSH75175	1 3/4"	BSH10175	1 3/4"	BSH10313	3 1/8"	BSH15225	2 1/4"	BSH15100	3 15/16"	BSH25325	3 1/4"	BSH25140	5 1/2"
BSH7546	1 3/16"	BSH1046	1 13/16"	BSH10319	3 3/16"	BSH15231	2 5/16"	BSH15400	4"	BSH25338	3 3/8"	BSH25575	5 3/4"
BSH75188	1 7/8"	BSH10188	1 7/8"	BSH10325	3 1/4"	BSH15238	2 3/8"	BSH15105	4 1/8"	BSH25350	3 1/2"	BSH25150	5 7/8"
BSH75194	1 15/16"	BSH10194	1 15/16"	BSH10338	3 3/8"	BSH15244	2 7/16"	BSH15419	4 3/16"	BSH25363	3 5/8"	BSH25600	6"
BSH75200	2"	BSH10200	2"	BSH10350	3 1/2"	BSH15250	2 1/2"	BSH15425	4 1/4"	BSH2595	3 3/4"	BSH25613	6 1/8"
-	-	BSH10206	2 1/16"	BSH10363	3 5/8"	BSH1565	2 9/16"	BSH15110	4 5/16"	BSH25388	3 7/8"	-	-
-	-	BSH10213	2 1/8"	BSH1095	3 3/4"	BSH15263	2 5/8"	BSH15438	4 3/8"	BSH25100	3 15/16"	-	-
-	-	BSH10219	2 3/16"	BSH10388	3 7/8"	BSH15269	2 11/16"	BSH15450	4 1/2"	BSH25400	4"	-	-
-	-	BSH10225	2 1/4"	-	-	BSH1570	2 3/4"	BSH15463	4 5/8"	BSH25105	4 1/8"	-	-

<sup>1)</sup> See page 254 for table of hexagon sizes of bolts, nuts and related thread diameters.

# Bolting Application Ideas

Enerpac professional series steel torque wrenches provide reliable controlled tightening solutions across the industry.

## **S3000 Square Drive Torque Wrench on Wind Tower erection and maintenance ►**

S3000 used to connect wind tower segments during assembly and maintenance. A robust but compact solution is required for tightening of bolts on wind tower sections. Large numbers of fasteners require precise application of torque to ensure joint integrity is achieved and maintained.

The Enerpac S-Series wrench was selected as it offers simple and reliable operation while providing accurate and repeatable results.



## **◀ W4000 Low Profile Torque Wrench on an ANSI Pipe Flange**

Throughout the Oil and Gas, Petrochemical and Processing Industries, pipeline joints, valves, pumps and machinery present challenges for controlled bolting.

The restricted access on this pipeline elbow was easily overcome by the selection of an Enerpac W-Series Torque Wrench.

The W-Series Wrenches offer reliability and control resulting in even and consistent torque being applied to all bolts.

## **S6000 on a High Volume Pump Unit ►**

High vibration requires long studs to be accurately tightened to the calculated preload.

During maintenance quick turnaround times are essential; S Series wrenches are chosen as they provide a large angle of nut rotation per stroke, offering speed and accuracy in a compact ergonomic tool.





▼ Shown: Drive units with interchangeable cassettes



## Rigid Steel Design

## The *Professional* Low Profile Solution

### Simplicity

- No tools are needed for changing the hexagon cassettes
- Innovative, pinless wrench construction incorporates quick release cylinder and automatic crank engagement
- Single 360° hydraulic swivel manifold complete with screw lock couplings increases wrench and hose manoeuvrability.

### Design

- Cylinders and low profile cassettes have been engineered to give ultra slim, compact low clearance tooling with a small nose radius
- Robust design with minimal parts enables easy on-site maintenance without special tools
- Nut sizes covered range from 30 - 115 mm (1 1/8 - 4 5/8 inch)
- Optimized strength-to-weight ratio
- Fast operation due to the large nut rotation per wrench cycle (30 degree rotation angle) and rapid return stroke.

### Reliability

- All wrenches are nickel-plated for excellent corrosion protection and improved durability in harsh environments
- All wrenches are fitted with bronze bushings to ensure the ratchet will never seize in the sideplates, thus eliminating costly repairs.

### Accuracy

- Constant torque output provides high accuracy across the full stroke
- In-line reaction foot ensures accuracy by reducing internal deflections.



### W-Series, Low Profile Torque Wrenches

This product range has been designed using state-of-the art CAD techniques to bring you the most advanced low profile torque wrench on the market. Safety, quality, toughness and reliability are built in.

During the design process every prototype was put through finite element stress analysis, photo-elastic modelling, rigorous cyclic testing and strain gauging.



### TSP - Pro Series Swivel

Featuring Tilt and Swivel technology the TSP provides 360° X-axis rotation and 160° Y-axis rotation.

### How to Order

Order as an accessory which can be fitted to existing W-Series wrenches.

Factory fitted to new W-Series wrenches: Suffix the wrench model number with "P" e.g.: **W2000-P**.

Page: 201



### Torque Wrench Hoses

Use Enerpac THQ-700 Series hoses with W-Series torque wrenches to ensure the integrity of your hydraulic system.

6 m long, 2 hoses	<b>THQ-706T</b>
12 m long, 2 hoses	<b>THQ-712T</b>

# Double-Acting Hydraulic Hexagon Torque Wrenches

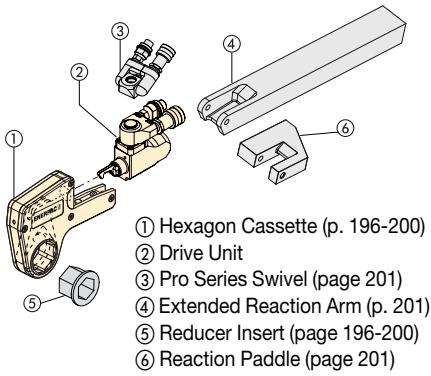

- ① Hexagon Cassette (p. 196-200)
- ② Drive Unit
- ③ Pro Series Swivel (page 201)
- ④ Extended Reaction Arm (p. 201)
- ⑤ Reducer Insert (page 196-200)
- ⑥ Reaction Paddle (page 201)



## Hexagon Cassettes and Reducer Inserts

Maximum versatility with the full range of interchangeable hexagon cassettes and hexagon reducing inserts is available in metric and inch sizes.

Page: 196

## W Series



Maximum Torque at 700 bar:

**20.337 Nm**

Hexagon Range:

**30 - 115 mm**

Nose Radius:

**31 - 87,5 mm**

Maximum Operating Pressure:

**700 bar**

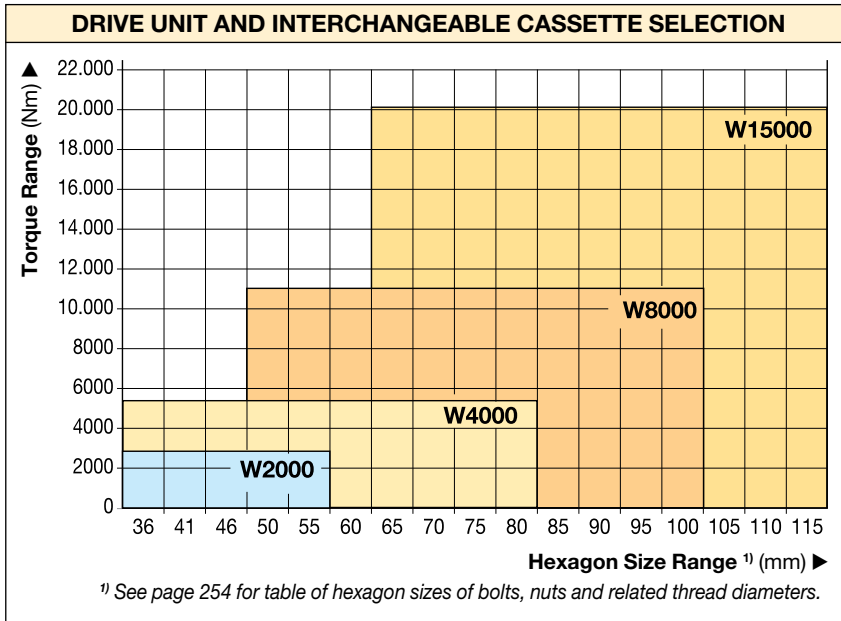

## Torque Wrench Pump Selection Matrix

For optimum speed and performance see the torque wrench and pump matrix.

Page: 202

▼ These rigid steel wrenches with low profile interchangeable hexagon cassettes guarantee durability and maximum versatility in bolting applications.

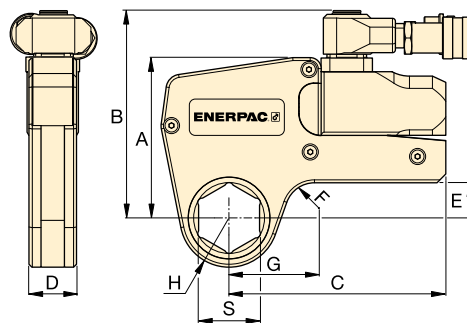

## ▼ SELECTION CHART

Hexagon Range *		Maximum Torque at 700 bar		Drive Unit Model Number **	Minimum Torque		Dimensions (mm) (see pages 196-200 for dimensions H, G and S)						Weight (drive unit without hexagon cassette) (kg)
(mm)	(inch)	(Nm)	(Ft.lbs)		(Nm)	(Ft.lbs)	A	B	C	D	E	F	
30 - 60	1 1/8 - 2 3/8	2712	2000	<b>W2000</b>	271	200	109	141	148	32	24	20	1,4
36 - 85	1 5/16 - 3 3/8	5423	4000	<b>W4000</b>	542	400	136	167	178	41	33	20	2,0
50 - 105	1 7/8 - 4 1/8	10.846	8000	<b>W8000</b>	1084	800	172	205	208	53	42	25	3,0
65 - 115	2 7/16 - 4 5/8	20.337	15.000	<b>W15000</b>	2033	1500	207	240	253	63	50	20	5,0

\* With in-line reaction foot.

\*\* To order a W-series wrench fitted with the TSP swivel, suffix the model number with "-P". Example: **W2000-P**.

# W2000, Inch-Cassettes & Reducer Inserts

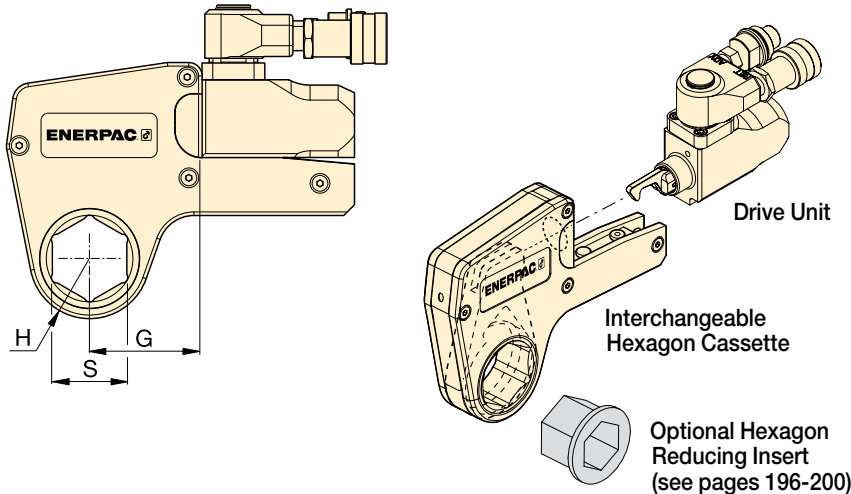

## W Series



Maximum Torque at 700 bar:  
**2712 Nm**

Hexagon Range:  
**1 1/8 - 2 3/8 inch**

Maximum Operating Pressure:  
**700 bar**



### Metric Sizes

For metric sizes of hexagon cassettes and reducer inserts see:

Page: **200**



### Hexagon Bolt and Nut Sizes

See the table for hexagon sizes of bolts, nuts and related thread diameters.

Page: **254**

## ▼ SELECTION CHART

Drive Unit Model Number	Hexagon Size <sup>1)</sup>	Nose Radius	Dim.	Model Number	Weight (kg)	Hexagon Reducer		Hexagon Reducer		Hexagon Reducer	
						Hexagon Reducer (inch)	Model Number	Hexagon Reducer (inch)	Model Number	Hexagon Reducer (inch)	Model Number
<b>W2000</b>	1 1/8	31	54	<b>W2102</b>	2,1	-	-	-	-	-	-
	1 3/16	31	54	<b>W2103</b>	2,1	-	-	-	-	-	-
	1 1/4	31	54	<b>W2104</b>	2,1	-	-	-	-	-	-
	1 5/16	31	54	<b>W2105</b>	2,1	-	-	-	-	-	-
	1 3/8	31	54	<b>W2106</b>	2,1	-	-	-	-	-	-
	1 7/16	31	54	<b>W2107</b>	2,1	1 7/16 - 1 1/8	<b>W2107R102</b>	-	-	-	-
	1 1/2	34	58	<b>W2108</b>	2,2	-	-	-	-	-	-
	1 9/16	34	58	<b>W2109</b>	2,2	-	-	-	-	-	-
	1 5/8	34	58	<b>W2110</b>	2,2	1 5/8 - 1 1/4	<b>W2110R104</b>	1 5/8 - 1 3/16	<b>W2110R103</b>	-	-
	1 11/16	37	61	<b>W2111</b>	2,2	-	-	-	-	-	-
	1 3/4	37	61	<b>W2112</b>	2,2	-	-	-	-	-	-
	1 13/16	37	61	<b>W2113</b>	2,2	1 13/16 - 1 7/16	<b>W2113R107</b>	1 13/16 - 1 1/4	<b>W2113R104</b>	-	-
	1 7/8	39	63	<b>W2114</b>	2,2	-	-	-	-	-	-
	1 9/16	39	63	<b>W2115</b>	2,2	-	-	-	-	-	-
	2	39	63	<b>W2200</b>	2,2	2 - 1 5/8	<b>W2200R110</b>	2 - 1 7/16	<b>W2200R107</b>	-	-
	2 1/16	42	69	<b>W2201</b>	2,3	-	-	-	-	-	-
	2 1/8	42	69	<b>W2202</b>	2,3	-	-	-	-	-	-
	2 3/16	42	69	<b>W2203</b>	2,3	2 3/16 - 1 13/16	<b>W2203R113</b>	2 3/16 - 1 5/8	<b>W2203R110</b>	2 3/16 - 1 7/16	<b>W2203R107</b>
	-	-	-	-	-	-	-	-	-	-	-
	2 1/4	45	65	<b>W2204</b>	2,2	-	-	-	-	-	-
2 5/16	45	65	<b>W2205</b>	2,2	-	-	-	-	-	-	
2 3/8	45	65	<b>W2206</b>	2,2	2 3/8 - 2	<b>W2206R200</b>	2 3/8 - 1 7/8	<b>W2206R114</b>	2 3/8 - 1 13/16	<b>W2206R113</b>	
-	-	-	-	-	-	2 3/8 - 1 1/2	<b>W2206R108</b>	2 3/8 - 1 7/16	<b>W2206R107</b>	-	

<sup>1)</sup> See page 254 for table of hexagon sizes of bolts, nuts and related thread diameters.

# W4000-Series, Inch-Cassettes & Reducer Inserts

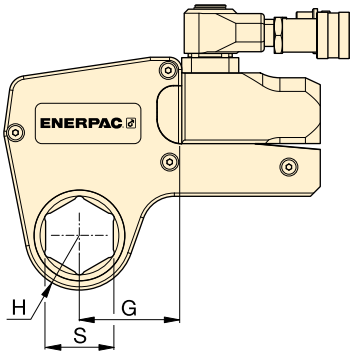

Maximum Torque at 700 bar:

**5423 Nm**

Hexagon Range:

**1<sup>5</sup>/<sub>16</sub> - 3<sup>3</sup>/<sub>8</sub> inch**

Maximum Operating Pressure:

**700 bar**

**W  
Series**



Drive Unit Model Number	Hexagon Size <sup>1)</sup>	Nose Radius	Dim.	Model Number	Weight (kg)	Hexagon Reducer		Hexagon Reducer		Hexagon Reducer	
						Hexagon Reducer (inch)	Model Number	Hexagon Reducer (inch)	Model Number	Hexagon Reducer (inch)	Model Number
W4000	1 <sup>5</sup> / <sub>16</sub>	37	61	W4105	3,7	-	-	-	-	-	-
	1 <sup>3</sup> / <sub>8</sub>	37	61	W4106	3,7	-	-	-	-	-	-
	1 <sup>7</sup> / <sub>16</sub>	37	61	W4107	3,7	-	-	-	-	-	-
	1 <sup>1</sup> / <sub>2</sub>	37	61	W4108	3,7	-	-	-	-	-	-
	1 <sup>9</sup> / <sub>16</sub>	37	61	W4109	3,7	-	-	-	-	-	-
	1 <sup>5</sup> / <sub>8</sub>	37	61	W4110	3,7	-	-	-	-	-	-
	1 <sup>11</sup> / <sub>16</sub>	40	64	W4111	3,8	-	-	-	-	-	-
	1 <sup>3</sup> / <sub>4</sub>	40	64	W4112	3,8	-	-	-	-	-	-
	1 <sup>13</sup> / <sub>16</sub>	40	64	W4113	3,8	-	-	-	-	-	-
	1 <sup>7</sup> / <sub>8</sub>	42	67	W4114	3,9	-	-	-	-	-	-
	1 <sup>15</sup> / <sub>16</sub>	42	67	W4115	3,9	-	-	-	-	-	-
	2	42	67	W4200	3,9	2 - 1 <sup>7</sup> / <sub>8</sub>	W4200R107	-	-	-	-
	2 <sup>1</sup> / <sub>16</sub>	44	73	W4201	4,0	-	-	-	-	-	-
	2 <sup>1</sup> / <sub>8</sub>	44	73	W4202	4,0	-	-	-	-	-	-
	2 <sup>3</sup> / <sub>16</sub>	44	73	W4203	4,0	2 <sup>3</sup> / <sub>16</sub> - 1 <sup>5</sup> / <sub>8</sub>	W4203R110	2 <sup>3</sup> / <sub>16</sub> - 1 <sup>7</sup> / <sub>16</sub>	W4203R107	2 <sup>3</sup> / <sub>16</sub> - 1 <sup>1</sup> / <sub>4</sub>	W4203R104
	2 <sup>1</sup> / <sub>4</sub>	47	71	W4204	4,1	-	-	-	-	-	-
	2 <sup>5</sup> / <sub>16</sub>	47	71	W4205	4,1	-	-	-	-	-	-
	2 <sup>3</sup> / <sub>8</sub>	47	71	W4206	4,1	2 <sup>3</sup> / <sub>8</sub> - 2	W4206R200	2 <sup>3</sup> / <sub>8</sub> - 1 <sup>13</sup> / <sub>16</sub>	W4206R113	2 <sup>3</sup> / <sub>8</sub> - 1 <sup>7</sup> / <sub>16</sub>	W4206R107
	-	-	-	-	-	2 <sup>3</sup> / <sub>8</sub> - 1 <sup>3</sup> / <sub>8</sub>	R4206R106	-	-	-	-
	2 <sup>7</sup> / <sub>16</sub>	50	76	W4207	4,1	2 <sup>7</sup> / <sub>16</sub> - 2	W4207R200	-	-	-	-
	2 <sup>1</sup> / <sub>2</sub>	50	76	W4208	4,1	2 <sup>1</sup> / <sub>2</sub> - 2	W4208R200	2 <sup>1</sup> / <sub>2</sub> - 1 <sup>7</sup> / <sub>16</sub>	W4208R113	-	-
	2 <sup>9</sup> / <sub>16</sub>	50	76	W4209	4,1	2 <sup>9</sup> / <sub>16</sub> - 2 <sup>3</sup> / <sub>16</sub>	W4209R203	2 <sup>9</sup> / <sub>16</sub> - 2 <sup>1</sup> / <sub>8</sub>	W4209R202	2 <sup>9</sup> / <sub>16</sub> - 2 <sup>1</sup> / <sub>16</sub>	W4208R201
	-	-	-	-	-	2 <sup>9</sup> / <sub>16</sub> - 2	W4209R200	2 <sup>9</sup> / <sub>16</sub> - 2 <sup>13</sup> / <sub>16</sub>	W4209R113	-	-
	2 <sup>5</sup> / <sub>8</sub>	53	78	W4210	4,2	-	-	-	-	-	-
	2 <sup>11</sup> / <sub>16</sub>	53	78	W4211	4,2	-	-	-	-	-	-
	2 <sup>3</sup> / <sub>4</sub>	53	78	W4212	4,2	2 <sup>3</sup> / <sub>4</sub> - 2 <sup>3</sup> / <sub>8</sub>	W4212R206	2 <sup>3</sup> / <sub>4</sub> - 2 <sup>3</sup> / <sub>16</sub>	W4212R203	2 <sup>3</sup> / <sub>4</sub> - 2 <sup>1</sup> / <sub>8</sub>	W4212R202
	2 <sup>13</sup> / <sub>16</sub>	55	82	W4213	4,3	-	-	-	-	-	-
	2 <sup>7</sup> / <sub>8</sub>	55	82	W4214	4,3	-	-	-	-	-	-
	2 <sup>15</sup> / <sub>16</sub>	55	82	W4215	4,3	2 <sup>15</sup> / <sub>16</sub> - 2 <sup>9</sup> / <sub>16</sub>	W4215R209	2 <sup>15</sup> / <sub>16</sub> - 2 <sup>3</sup> / <sub>8</sub>	W4215R206	2 <sup>15</sup> / <sub>16</sub> - 2 <sup>3</sup> / <sub>16</sub>	W4215R203
	-	-	-	-	-	2 <sup>15</sup> / <sub>16</sub> - 2	W4215R200	-	-	-	-
	3	59	84	W4300	4,4	3 - 2 <sup>3</sup> / <sub>16</sub>	W4300R203	-	-	-	-
	3 <sup>1</sup> / <sub>16</sub>	59	84	W4301	4,4	-	-	-	-	-	-
	3 <sup>1</sup> / <sub>8</sub>	59	84	W4302	4,4	3 <sup>1</sup> / <sub>8</sub> - 2 <sup>3</sup> / <sub>4</sub>	W4302R212	3 <sup>1</sup> / <sub>8</sub> - 2 <sup>9</sup> / <sub>16</sub>	W4302R209	3 <sup>1</sup> / <sub>8</sub> - 2 <sup>3</sup> / <sub>8</sub>	W4302R206
	-	-	-	-	-	3 <sup>1</sup> / <sub>8</sub> - 2 <sup>5</sup> / <sub>16</sub>	W4302R205	3 <sup>1</sup> / <sub>8</sub> - 2 <sup>1</sup> / <sub>4</sub>	W4302R204	3 <sup>1</sup> / <sub>8</sub> - 2 <sup>3</sup> / <sub>16</sub>	W4302R203
	-	-	-	-	-	3 <sup>1</sup> / <sub>8</sub> - 2 <sup>1</sup> / <sub>8</sub>	W4302R202	3 <sup>1</sup> / <sub>8</sub> - 2	W4302R200	-	-
	3 <sup>3</sup> / <sub>16</sub>	62	86	W4303	4,5	-	-	-	-	-	-
3 <sup>1</sup> / <sub>4</sub>	62	86	W4304	4,5	-	-	-	-	-	-	
3 <sup>5</sup> / <sub>16</sub>	62	86	W4305	4,5	-	-	-	-	-	-	
3 <sup>3</sup> / <sub>8</sub>	62	86	W4306	4,5	-	-	-	-	-	-	

<sup>1)</sup> See page 254 for table of hexagon sizes of bolts, nuts and related thread diameters.



# W8000-Series, Inch-Cassettes & Reducers

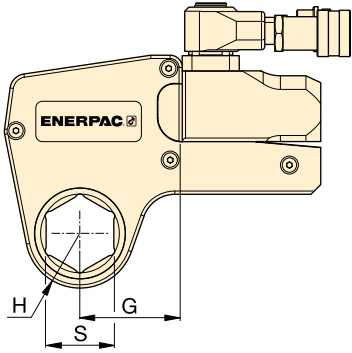

Maximum Torque at 700 bar:

**10.846 Nm**

Hexagon Range:

**1<sup>7</sup>/<sub>8</sub> - 4<sup>1</sup>/<sub>8</sub> inch**

Maximum Operating Pressure:

**700 bar**

**W**  
Series



▼ SELECTION CHART

Drive Unit Model Number	Hexagon Size <sup>1)</sup>	Nose Radius	Dim.	Model Number	Weight (kg)	Hexagon Reducer		Hexagon Reducer		Hexagon Reducer	
						Hexagon Reducer (inch)	Model Number	Hexagon Reducer (inch)	Model Number	Hexagon Reducer (inch)	Model Number
W8000	1 <sup>7</sup> / <sub>8</sub>	45	78	W8114	8,1	-	-	-	-	-	-
	1 <sup>15</sup> / <sub>16</sub>	45	78	W8115	8,1	-	-	-	-	-	-
	2	45	78	W8200	8,1	-	-	-	-	-	-
	2 <sup>1</sup> / <sub>16</sub>	48	80	W8201	8,1	-	-	-	-	-	-
	2 <sup>1</sup> / <sub>8</sub>	48	80	W8202	8,1	-	-	-	-	-	-
	2 <sup>3</sup> / <sub>16</sub>	48	80	W8203	8,1	-	-	-	-	-	-
	2 <sup>1</sup> / <sub>4</sub>	51	83	W8204	8,1	-	-	-	-	-	-
	2 <sup>5</sup> / <sub>16</sub>	51	83	W8205	8,1	-	-	-	-	-	-
	2 <sup>3</sup> / <sub>8</sub>	51	83	W8206	8,1	-	-	-	-	-	-
	2 <sup>7</sup> / <sub>16</sub>	53	86	W8207	8,1	-	-	-	-	-	-
	2 <sup>1</sup> / <sub>2</sub>	53	86	W8208	8,1	-	-	-	-	-	-
	2 <sup>9</sup> / <sub>16</sub>	53	86	W8209	8,1	2 <sup>9</sup> / <sub>16</sub> - 2	W8209R200	-	-	-	-
	2 <sup>5</sup> / <sub>8</sub>	56	85	W8210	8,1	-	-	-	-	-	-
	2 <sup>11</sup> / <sub>16</sub>	56	85	W8211	7,9	-	-	-	-	-	-
	2 <sup>3</sup> / <sub>4</sub>	56	85	W8212	7,9	2 <sup>3</sup> / <sub>4</sub> - 2 <sup>3</sup> / <sub>16</sub>	W8212R203	-	-	-	-
	2 <sup>13</sup> / <sub>16</sub>	58	85	W8213	7,9	-	-	-	-	-	-
	2 <sup>7</sup> / <sub>8</sub>	58	85	W8214	7,9	-	-	-	-	-	-
	2 <sup>15</sup> / <sub>16</sub>	58	85	W8215	7,9	2 <sup>15</sup> / <sub>16</sub> - 2 <sup>3</sup> / <sub>8</sub>	W8215R206	2 <sup>15</sup> / <sub>16</sub> - 2 <sup>3</sup> / <sub>16</sub>	W8215R203	-	-
	3	61	90	W8300	8,0	-	-	-	-	-	-
	3 <sup>1</sup> / <sub>16</sub>	61	90	W8301	8,0	-	-	-	-	-	-
	3 <sup>1</sup> / <sub>8</sub>	61	90	W8302	8,0	3 <sup>1</sup> / <sub>8</sub> - 2 <sup>9</sup> / <sub>16</sub>	W8302R209	3 <sup>1</sup> / <sub>8</sub> - 2 <sup>3</sup> / <sub>8</sub>	W8302R206	3 <sup>1</sup> / <sub>8</sub> - 2 <sup>9</sup> / <sub>16</sub>	W8302R203
	-	-	-	-	-	-	3 <sup>1</sup> / <sub>8</sub> - 2	W8302R200	-	-	-
	3 <sup>3</sup> / <sub>16</sub>	66	92	W8303	8,2	-	-	-	-	-	-
	3 <sup>1</sup> / <sub>4</sub>	66	92	W8304	8,2	-	-	-	-	-	-
	3 <sup>5</sup> / <sub>16</sub>	66	92	W8305	8,2	-	-	-	-	-	-
	3 <sup>3</sup> / <sub>8</sub>	66	92	W8306	8,2	-	-	-	-	-	-
	3 <sup>7</sup> / <sub>16</sub>	66	92	W8307I	8,2	-	-	-	-	-	-
	3 <sup>1</sup> / <sub>2</sub>	66	92	W8308	8,2	3 <sup>1</sup> / <sub>2</sub> - 3	W8308R300	3 <sup>1</sup> / <sub>2</sub> - 2 <sup>15</sup> / <sub>16</sub>	W8308R215	3 <sup>1</sup> / <sub>2</sub> - 2 <sup>3</sup> / <sub>4</sub>	W8308R212
	3 <sup>9</sup> / <sub>16</sub>	74	103	W8309	8,8	-	-	-	-	-	-
	3 <sup>5</sup> / <sub>8</sub>	74	103	W8310	8,8	-	-	-	-	-	-
	3 <sup>11</sup> / <sub>16</sub>	74	103	W8311	8,8	-	-	-	-	-	-
	3 <sup>3</sup> / <sub>4</sub>	74	103	W8312	8,8	3 <sup>3</sup> / <sub>4</sub> - 3 <sup>1</sup> / <sub>8</sub>	W8312R302	3 <sup>3</sup> / <sub>4</sub> - 2 <sup>15</sup> / <sub>16</sub>	W8312R215	3 <sup>3</sup> / <sub>4</sub> - 2 <sup>3</sup> / <sub>4</sub>	W8312R212
3 <sup>13</sup> / <sub>16</sub>	74	103	W8313	8,8	-	-	-	-	-	-	
3 <sup>7</sup> / <sub>8</sub>	74	103	W8314	8,8	3 <sup>7</sup> / <sub>8</sub> - 3 <sup>1</sup> / <sub>8</sub>	W8314R302	3 <sup>7</sup> / <sub>8</sub> - 2 <sup>15</sup> / <sub>16</sub>	W8314R215	-	-	
3 <sup>15</sup> / <sub>16</sub>	80	110	W8315	9,3	-	-	-	-	-	-	
4	80	110	W8400	9,3	-	-	-	-	-	-	
4 <sup>1</sup> / <sub>16</sub>	80	110	W8401I	9,3	-	-	-	-	-	-	
4 <sup>1</sup> / <sub>8</sub>	80	110	W8402	9,3	-	-	-	-	-	-	

<sup>1)</sup> See page 254 for table of hexagon sizes of bolts, nuts and related thread diameters.

# W15000-Series, Inch-Cassettes & Reducer Inserts

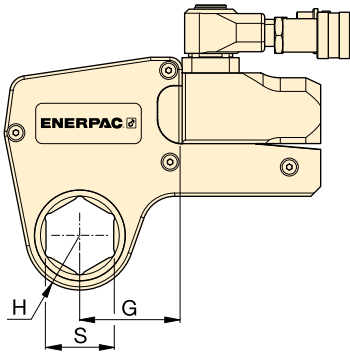

Maximum Torque at 700 bar:

**20.337 Nm**

Hexagon Range:

**2<sup>7</sup>/<sub>16</sub> - 4<sup>5</sup>/<sub>8</sub> inch**

Maximum Operating Pressure:

**700 bar**

**W Series**



## ▼ SELECTION CHART

Drive Unit Model Number	Hexagon Size <sup>1)</sup>	Nose Radius	Dim.	Model Number	Weight (kg)	Hexagon Reducer		Hexagon Reducer		Hexagon Reducer	
						Hexagon Reducer (inch)	Model Number	Hexagon Reducer (inch)	Model Number	Hexagon Reducer (inch)	Model Number
W15000	2 <sup>7</sup> / <sub>16</sub>	59	89	W15207	13,6	-	-	-	-	-	-
	2 <sup>1</sup> / <sub>2</sub>	59	89	W15208	13,6	-	-	-	-	-	-
	2 <sup>9</sup> / <sub>16</sub>	59	89	W15209	13,6	-	-	-	-	-	-
	2 <sup>5</sup> / <sub>8</sub>	59	89	W15210	13,6	-	-	-	-	-	-
	2 <sup>11</sup> / <sub>16</sub>	59	89	W15211	13,6	-	-	-	-	-	-
	2 <sup>3</sup> / <sub>4</sub>	59	89	W15212	13,6	-	-	-	-	-	-
	2 <sup>13</sup> / <sub>16</sub>	62	91	W15213	13,7	-	-	-	-	-	-
	2 <sup>7</sup> / <sub>8</sub>	62	91	W15214	13,7	-	-	-	-	-	-
	2 <sup>15</sup> / <sub>16</sub>	62	91	W15215	13,7	-	-	-	-	-	-
	3	65	93	W15300	13,8	3 - 2 <sup>1</sup> / <sub>8</sub>	W15300R202	-	-	-	-
	3 <sup>1</sup> / <sub>16</sub>	65	93	W15301	13,8	-	-	-	-	-	-
	3 <sup>1</sup> / <sub>8</sub>	65	93	W15302	13,8	3 <sup>1</sup> / <sub>8</sub> - 2 <sup>9</sup> / <sub>16</sub>	W15302R209	-	-	-	-
	3 <sup>3</sup> / <sub>16</sub>	70	97	W15303	14,1	-	-	-	-	-	-
	3 <sup>1</sup> / <sub>4</sub>	70	97	W15304	14,1	-	-	-	-	-	-
	3 <sup>5</sup> / <sub>16</sub>	70	97	W15305	14,1	-	-	-	-	-	-
	3 <sup>3</sup> / <sub>8</sub>	70	97	W15306	14,1	-	-	-	-	-	-
	3 <sup>7</sup> / <sub>16</sub>	70	97	W15307I	14,1	-	-	-	-	-	-
	3 <sup>1</sup> / <sub>2</sub>	70	97	W15308	14,1	3 <sup>1</sup> / <sub>2</sub> - 2 <sup>15</sup> / <sub>16</sub>	W15308R215	3 <sup>1</sup> / <sub>2</sub> - 2 <sup>3</sup> / <sub>4</sub>	W15308R212	-	-
	3 <sup>9</sup> / <sub>16</sub>	75	102	W15309	14,6	-	-	-	-	-	-
	3 <sup>5</sup> / <sub>8</sub>	75	102	W15310	14,6	-	-	-	-	-	-
	3 <sup>11</sup> / <sub>16</sub>	75	102	W15311	14,6	-	-	-	-	-	-
	3 <sup>3</sup> / <sub>4</sub>	75	102	W15312	14,6	3 <sup>3</sup> / <sub>4</sub> - 3 <sup>1</sup> / <sub>8</sub>	W15312R302	3 <sup>3</sup> / <sub>4</sub> - 2 <sup>15</sup> / <sub>16</sub>	W15312R215	-	-
	3 <sup>13</sup> / <sub>16</sub>	75	102	W15313	14,5	-	-	-	-	-	-
	3 <sup>7</sup> / <sub>8</sub>	75	102	W15314	14,5	3 <sup>7</sup> / <sub>8</sub> - 3 <sup>1</sup> / <sub>8</sub>	W15314R302	3 <sup>7</sup> / <sub>8</sub> - 2 <sup>15</sup> / <sub>16</sub>	W15314R215	-	-
	3 <sup>15</sup> / <sub>16</sub>	81	103	W15315	14,8	-	-	-	-	-	-
	4	81	103	W15400	14,8	-	-	-	-	-	-
	4 <sup>1</sup> / <sub>16</sub>	81	103	W15401I	14,8	-	-	-	-	-	-
	4 <sup>1</sup> / <sub>8</sub>	81	103	W15402	14,8	4 <sup>1</sup> / <sub>8</sub> - 3 <sup>1</sup> / <sub>2</sub>	W15402R308	4 <sup>1</sup> / <sub>8</sub> - 3 <sup>5</sup> / <sub>16</sub>	W15402R305	4 <sup>1</sup> / <sub>8</sub> - 3 <sup>1</sup> / <sub>4</sub>	W15402R304
	4 <sup>3</sup> / <sub>16</sub>	81	103	W15403I	14,8	-	-	-	-	-	-
	4 <sup>1</sup> / <sub>4</sub>	81	103	W15404	14,8	4 <sup>1</sup> / <sub>4</sub> - 3 <sup>1</sup> / <sub>2</sub>	W15404R308	4 <sup>1</sup> / <sub>4</sub> - 3 <sup>1</sup> / <sub>8</sub>	W15404R302	-	-
	4 <sup>5</sup> / <sub>16</sub>	88	115	W15405	15,1	-	-	-	-	-	-
	4 <sup>3</sup> / <sub>8</sub>	88	115	W15406	15,1	-	-	-	-	-	-
4 <sup>7</sup> / <sub>16</sub>	88	115	W15407	15,1	-	-	-	-	-	-	
4 <sup>1</sup> / <sub>2</sub>	88	115	W15408I	15,1	-	-	-	-	-	-	
4 <sup>9</sup> / <sub>16</sub>	88	115	W15409I	15,1	-	-	-	-	-	-	
4 <sup>5</sup> / <sub>8</sub>	88	115	W15410I	15,1	4 <sup>5</sup> / <sub>8</sub> - 3 <sup>15</sup> / <sub>16</sub>	W15410R315	4 <sup>5</sup> / <sub>8</sub> - 3 <sup>7</sup> / <sub>8</sub>	W15410R314	4 <sup>5</sup> / <sub>8</sub> - 3 <sup>3</sup> / <sub>4</sub>	W15410R312	
-	-	-	-	-	-	4 <sup>5</sup> / <sub>8</sub> - 3 <sup>1</sup> / <sub>2</sub>	W15410R308	-	-	-	
-	-	-	-	-	-	-	-	-	-	-	

<sup>1)</sup> See page 254 for table of hexagon sizes of bolts, nuts and related thread diameters.

# W-Series, Metric Cassettes and Reducers

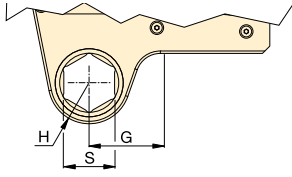





Hexagon Range:  
**30 - 115 mm**

Maximum Operating Pressure:  
**700 bar**

**W**  
Series



▼ SELECTION CHART

Drive Unit Model Number	Hexagon Size <sup>1)</sup> S (mm)	Nose Radius H (mm)	Dim. G (mm)	Model Number	 (kg)						
						Hexagon Reducer (mm)	Model Number	Hexagon Reducer (mm)	Model Number	Hexagon Reducer (mm)	Model Number
<b>W2000</b>	30	31	54	W2103	2,1	-	-	-	-	-	-
	32	31	54	W2104	2,1	-	-	-	-	-	-
	36	31	54	W2107	2,1	-	-	-	-	-	-
	38	34	58	W2108	2,2	-	-	-	-	-	-
	41	34	58	W2110	2,2	41 - 32	W2110R104	41 - 30	W2110R103	41 - 24	W2110R024M
	46	34	61	W2113	2,2	46 - 36	W2113R107	46 - 32	W2113R104	-	-
	50	39	63	W2200	2,2	50 - 41	W2200R110	50 - 36	W2200R107	-	-
	55	42	69	W2203	2,3	55 - 46	W2203R113	55 - 41	W2203R110	55 - 36	W2203R107
	60	45	65	W2206	2,2	60 - 50	W2206R200	60 - 46	W2206R113	60 - 41	W2206R110
-	-	-	-	-	60 - 36	W2206R107	-	-	-	-	
<b>W4000</b>	36	37	61	W4107	3,7	-	-	-	-	-	-
	41	37	61	W4110	3,7	-	-	-	-	-	-
	46	40	64	W4113	3,8	-	-	-	-	-	-
	50	42	67	W4200	3,9	50 - 36	W4200R107	-	-	-	-
	55	44	73	W4203	4,0	55 - 41	W4203R110	55 - 36	W4203R107	55 - 32	W4203R104
	60	47	71	W4206	4,1	60 - 50	W4206R200	60 - 46	W4206R113	60 - 36	W4206R107
	65	50	76	W4209	4,1	65 - 55	W4209R203	65 - 50	W4209R200	65 - 46	W4209R113
	70	53	78	W4212	4,2	70 - 60	W4212R206	70 - 55	W4212R203	-	-
	75	55	82	W4215	4,3	75 - 65	W4215R209	75 - 60	W4215R206	-	-
	-	-	-	W4215	-	75 - 55	W4215R203	75 - 50	W4215R200	-	-
	80	59	84	W4302	4,4	80 - 75	W4302R215	80 - 70	W4302R212	80 - 65	W4302R209
	-	-	-	W4302	-	80 - 55	W4302R203	80 - 50	W4302R200	-	-
	85	62	86	W4085M	4,5	-	-	-	-	-	-
<b>W8000</b>	50	45	78	W8200	8,1	-	-	-	-	-	-
	55	48	80	W8203	8,1	-	-	-	-	-	-
	60	51	83	W8206	8,1	-	-	-	-	-	-
	65	56	85	W8209	8,1	65 - 50	W8209R200	-	-	-	-
	70	56	85	W8212	7,9	70 - 55	W8212R203	-	-	-	-
	75	58	85	W8215	7,9	75 - 60	W8215R206	75 - 55	W8215R203	-	-
	80	61	90	W8302	8	80 - 65	W8302R209	80 - 60	W8302R206	80 - 55	W8302R203
	-	-	-	-	-	80 - 50	W8302R200	-	-	-	-
	85	66	92	W8085M	8,2	85 - 70	W8085R070M	85 - 65	W8085R065M	85 - 60	W8085R060M
	-	-	-	-	-	85 - 55	W8085R055M	-	-	-	-
	90	74	103	W8090M	8,8	90 - 75	W8090R075M	-	-	-	-
	95	74	103	W8312	8,8	95 - 80	W8312R302	95 - 75	W8312R215	-	-
	100	80	110	W8315	9,3	-	-	-	-	-	-
<b>W15000</b>	105	80	110	W8402	9,3	-	-	-	-	-	-
	65	59	89	W15209	13,6	-	-	-	-	-	-
	70	59	89	W15212	13,6	-	-	-	-	-	-
	75	62	91	W15215	13,7	-	-	-	-	-	-
	80	65	93	W15302	13,8	80 - 65	W15302R209	-	-	-	-
	85	70	97	W15085M	14,1	85 - 70	W15085R070M	-	-	-	-
	90	75	102	W15090M	14,5	90 - 75	W15090R75M	-	-	-	-
	95	75	102	W15312	14,6	95 - 80	W15312R302	95 - 75	W15312R215	-	-
	100	81	103	W15315	14,8	-	-	-	-	-	-
	105	81	103	W15402	14,8	105 - 90	W15402R090M	-	-	-	-
	110	88	115	W15405	15,1	110 - 95	W15110R095M	-	-	-	-
115	88	115	W15115M	15,1	115 - 100	W15115R100M	-	-	-	-	

<sup>1)</sup> See page 254 for table of hexagon sizes of bolts, nuts and related thread diameters.

# Accessories for W-Series Torque Wrenches

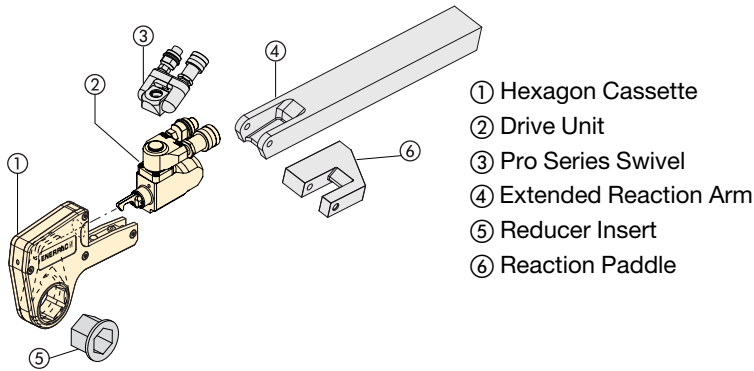

- ① Hexagon Cassette
- ② Drive Unit
- ③ Pro Series Swivel
- ④ Extended Reaction Arm
- ⑤ Reducer Insert
- ⑥ Reaction Paddle

## TSP WTE WRP Series



### TSP-Series, Pro Series Swivels

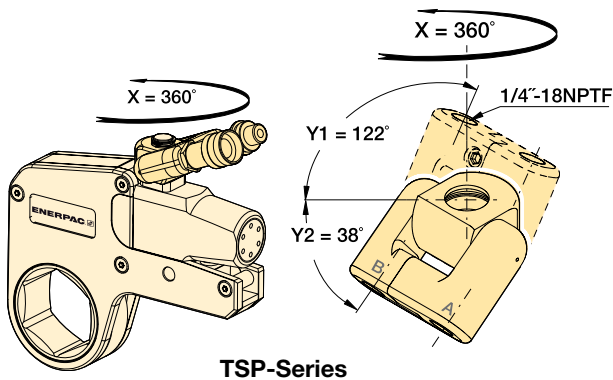

- Featuring Tilt and Swivel technology
- 360° X-axis and 160° Y-axis rotation
- Increases tool fit in restricted access areas
- Simplifies hose placement.

For Torque Wrench Model Number	Model Number	Maximum Pressure (bar)	 (kg)
W2000, W4000	<b>TSP100</b>	700	0,2
W8000, W15000	<b>TSP200</b>	700	0,2

To order a W-series wrench fitted with the TSP swivel, add suffix "P" to the model number. Example: **W2000-P**.

### WTE-Series, Extended Reaction Arm

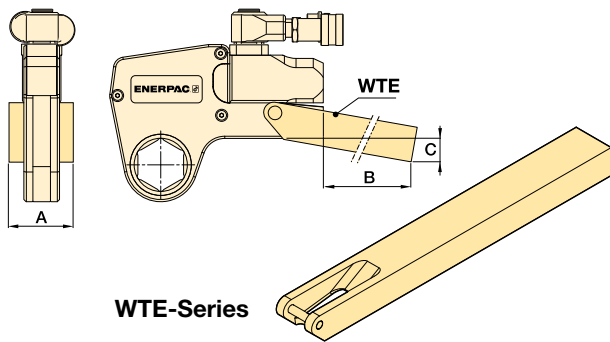

- Full torque rated
- Increases tool fit in restricted access areas.

For Torque Wrench Model Number	Model Number	Dimensions (mm)			 (kg)*
		A	B	C	
W2000	<b>WTE20</b>	56	398	76	2,6
W4000	<b>WTE40</b>	66	436	74	4,6
W8000	<b>WTE80</b>	85	449	66	7,6
W15000	<b>WTE150</b>	102	498	72	12,0

\* Weights indicated are for the accessories only and do not include the wrench.

### WRP-Series, Low Profile Reaction Paddles

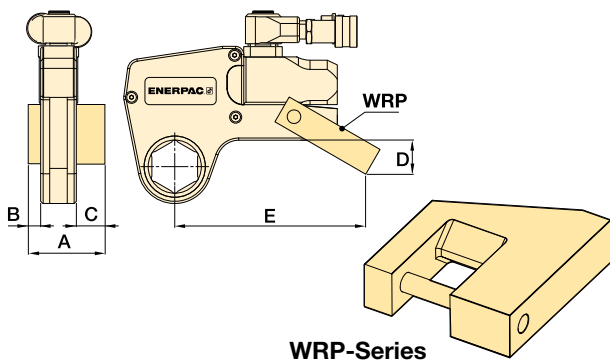

- Lightweight interchangeable design
- Allows for offset reaction when in-line reaction is not available.

For Torque Wrench Model Nr.	Model Number	Dimensions (mm)					 (kg)*
		A	B	C	D	E	
W2000	<b>WRP20</b>	84	16	35	45	148	0,4
W4000	<b>WRP40</b>	109	21	47	59	190	0,8
W8000	<b>WRP80</b>	137	26	57	69	223	2,0
W15000	<b>WRP150</b>	165	32	69	87	257	3,9

\* Weights indicated are for the accessories only and do not include the wrench.





## Optimum Torque Wrench and Pump Combinations

For optimum speed and performance Enerpac recommends the following system set-up with wrench-pump-hose combinations.

		ELECTRIC PUMPS			AIR DRIVEN PUMPS		TWIN HOSES	
		PMU-Series	ZU4T-Series	ZE4T, ZE5T-Series	PTA-Series	ZA4T-Series	THQ-Series	
		Page: 203	Page: 204	Page: 208	Page: 210	Page: 212		
		Flow at rated pressure: 0,33 l/min 115V, 1 ph	Flow at rated pressure: 0,33 l/min 230V, 1 ph	Flow at rated pressure: 1,0 l/min 115V, 1 ph 230V, 1 ph	Flow at rated pressure: 0,82-1,64 l/min 115V, 1ph 230V, 1 or 3 ph	Flow at rated pressure: 0,33 l/min	Flow at rated pressure: 1,0 l/min	
700 bar Torque Wrenches Model Number	 188	PMU-10427-Q	PMU-10422-Q	Any ZU4T-Series pump may be used.	Any ZE-Series pump may be used.	PTA-1404-Q	Any ZA4T-Series pump may be used.	THQ-706T (6m) THQ-712T (12m)
	 194	PMU-10427-Q	PMU-10422-Q			PTA-1404-Q		



### ZU4T-Series Electric Torque Wrench Pump

Utilizing a universal motor, the ZU4T-Series has excellent low voltage characteristics. It works well with long extension cords or generator driven electrical power supplies. A field proven, efficient design ensures this pump is dependable and will draw less current — lowering your operating costs.

The ZU4T-Series pumps are available in **Pro** and **Classic** formats.

**ZU4T Pro** pumps have an LCD feature to display torque or pressure, selectable torque wrench, and self diagnostics – premium features not available on any other pump.

**ZU4T Classic** pumps feature an analog gauge and a basic electrical package to deliver durable, safe and efficient hydraulic power.

### ZE4T and ZE5T-Series Electric Torque Wrench Pump

The ZE-Series features premium options, such as the LCD to display torque or pressure values, and self diagnostics. These pumps utilize an induction motor, making the ZE-Series the coolest and quietest pumps in their class.

### ZA4T-Series Air Torque Wrench Pump

Utilizing the highly efficient design of the Z-Class pumping element, this air driven pump is best suited to power medium to large size torque wrenches.



### 800 bar Torque Wrench Pumps

Pumps are available for higher pressure wrenches. See pump product pages.



### IMPORTANT!

Always make sure that the torque scale on the pump matches the torque size for accurate torque settings. Valid only for PMU, PTA and ZA4T-Series torque wrench pumps.



### Torque Wrench Couplers

See the “System Components” in this catalogue for ordering couplers for hydraulic torque wrenches.

# Portable Electric Torque Wrench Pumps

▼ Shown: **PMU-10422**



- Powerful two-speed pump is lightweight and easy to carry
- Standard heat exchanger package keeps pump cool under extreme use
- Glycerin filled gauge with scales reading in psi and bar
- Transparent overlays in Nm and Ft.lbs for all Enerpac torque wrenches provide a quick torque reference
- Universal motor for a high power-to-weight ratio; generates full pressure on as little as 50% of the rated line voltage
- Adjustable pressure relief valve for accurate torque adjustments and precise repeatability.

## PMU Series



Reservoir Capacity:

**1,9 - 3,8 litres**

Flow at Rated Pressure:

**0,33 l/min**

Motor Size:

**0,37 kW**

Maximum Operating Pressure:

**700 - 800 bar**



### Torque Wrench Hoses

Use Enerpac twin safety hoses to connect your torque wrench to the pump.

For 700 bar	Model-Nr.
6 m long, 2 hoses	<b>THQ-706T</b>
12 m long, 2 hoses	<b>THQ-712T</b>
For 800 bar	
6 m long, 2 hoses	<b>THC-7062</b>
12 m long, 2 hoses	<b>THC-7122</b>



### Gauge Overlay Kit

Available separately for use with PMU-Series pumps: **GT-4015-Q** includes overlays for all S- and W-Series torque wrenches.

**GT-4015** includes overlays for all SQD and HXD torque wrenches.

## ▼ SELECTION CHART

For Use With Torque Wrenches		Maximum Pressure Rating (bar)		Oil Flow Rate (l/min)		Model Number	Useable Oil Capacity (litres)	Electric Motor (Volt-phase-Hz)	Dimensions L x W x H (mm)	Weight (kg)
		1 <sup>st</sup> stage	2 <sup>nd</sup> stage	1 <sup>st</sup> stage	2 <sup>nd</sup> stage					
S1500 S3000	W2000	48	700	3,3	0,33	<b>PMU-10427-Q</b>	1,9	115 - 1 - 50/60	431x280x381	24
		48	700	3,3	0,33	<b>PMU-10447-Q</b>	3,8	115 - 1 - 50/60	431x330x381	27
	W4000	48	700	3,3	0,33	<b>PMU-10422-Q</b>	1,9	230 - 1 - 50/60	431x280x381	24
		48	700	3,3	0,33	<b>PMU-10442-Q</b>	3,8	230 - 1 - 50/60	431x330x381	27
SQD-25-I SQD-50-I	HXD-30	48	800	3,3	0,33	<b>PMU-10427</b>	1,9	115 - 1 - 50/60	431x280x381	24
		48	800	3,3	0,33	<b>PMU-10447</b>	3,8	115 - 1 - 50/60	431x330x381	27
	HXD-60	48	800	3,3	0,33	<b>PMU-10422</b>	1,9	230 - 1 - 50/60	431x280x381	24
		48	800	3,3	0,33	<b>PMU-10442</b>	3,8	230 - 1 - 50/60	431x330x381	27

# ZU4T, Electric Torque Wrench Pumps

▼ ZU4204TE-Q, ZU4204BE-Q



- Features **Z-Class** high-efficiency pump design; higher oil flow and bypass pressure, cooler running and requires 18% less current draw than comparable pumps
- Powerful 1,25 kW universal electric motor provides high power-to-weight ratio and excellent low-voltage operating characteristics
- High-strength, molded composite shroud protects motor and electrical components, while providing an ergonomic, non-conductive handle for easy transport
- Low-voltage pendant provides additional safety for the operator

### Pro Series pump only

- LCD readout provides pressure display and a number of diagnostic and readout capabilities never before offered on a portable electric pump
- AutoCycle feature provides continuous cycle operation of the torque wrench as long as the advance button is pressed (pump can be used with or without auto cycle feature).



◀ Any brand of hydraulic torque wrench can be powered by the portable ZU4-Series torque wrench pump.

## Z Tough, Dependable Innovative CLASS



### FIRMWARE 7.0, for Pro-Series

- Display torque in Nm or Ft.lbs
- Display pressure in bar, MPa or psi
- Torque wrench model is selectable
- “Auto cycle” setting easily programmable.



### Classic Electrical

Basic electrical package includes mechanical contactor, ON/OFF toggle switch, pendant with

electro-mechanical push buttons, 24V transformer timer and operator accessible circuit breaker.



### Pro-Series

Back-lit LCD and Pressure Transducer featuring Auto-Cycle Technology.

- Digital read-out and “Autocycle” setting
- Pump usage information, hour and cycle counts
- Low-voltage warning and recording
- Self-test and diagnostic capabilities
- Information can be displayed in English, French, German, Italian, Spanish and Portuguese
- Pressure transducer is more accurate and durable than analog gauges
- Easy-viewing variable rate display
- Display pressure in bar, MPa or psi.

# ZU4T-Series, Torque Wrench Pumps



## Z-Class – A Pump For Every Application

Patented **Z-Class** pump technology provides high by-pass pressures for increased productivity – important in applications using long hose runs and high pressure-drop circuits, like heavy lifting or certain double-acting tools.

Enerpac ZU4T-Series pumps are built to power small to large torque wrenches. Choosing the right ZU4T-Series torque wrench pump for your application is easy.

### Classic Electric Torque Wrench Pump

- The Classic has traditional electro-mechanical components (transformers, relays and switches) in place of solid-state electronics. The Classic delivers durable, safe and efficient hydraulic power.

## Pro Series Electric Torque Wrench Pump

- Digital (LCD) display features a built-in hour meter, pressure display and shows self-diagnostic, cycle-count and low voltage warning information.

These premium features are not available on any other pump – anywhere!

- Auto-Cycle feature provides continuous cycle operation of the torque wrench as long as the advance button is pressed (pump can be used with or without Auto-Cycle feature).

## ZU4T Series



Reservoir Capacity:

**4,0 and 6,6 litres**

Flow at Rated Pressure:

**1,0 l/min**

Motor Size:

**1,25 kW**

Maximum Operating Pressure:

**700 and 800 bar**



### Torque Wrench Pump Selection Matrix

For optimum speed and performance see the torque wrench pump and hose selection matrix.

Page: 202

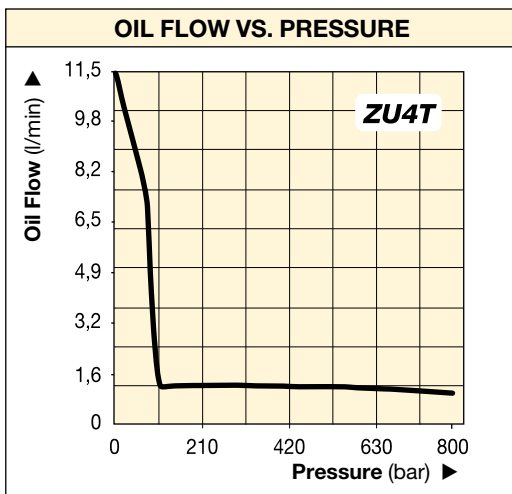

## COMMON PUMP MODELS

	For Use With Torque Wrenches	Model Number <sup>1) 4)</sup>	Motor Electrical Specification	Usable Oil Capacity (litres)	(kg)
Pro Series	All wrenches	ZU4204TB-Q	115 VAC, 1-ph	4,0	32
		ZU4208TB-Q	115 VAC, 1-ph	6,6	34
		ZU4204TE-Q <sup>2)</sup>	208-240 VAC, 1-ph	4,0	32
		ZU4208TE-Q <sup>2)</sup>	208-240 VAC, 1-ph	6,6	34
		ZU4204TI-Q <sup>3)</sup>	208-240 VAC, 1-ph	4,0	32
		ZU4208TI-Q <sup>3)</sup>	208-240 VAC, 1-ph	6,6	34
Classic	All wrenches	ZU4204BB-QH	115 VAC, 1-ph	4,0	37
		ZU4204BB-Q	115 VAC, 1-ph	4,0	33
		ZU4208BE-QH <sup>2)</sup>	208-240 VAC, 1-ph	6,6	38
		ZU4204BE-Q <sup>2)</sup>	208-240 VAC, 1-ph	4,0	34
		ZU4208BI-QH <sup>3)</sup>	208-240 VAC, 1-ph	6,6	40
		ZU4208BI-Q <sup>3)</sup>	208-240 VAC, 1-ph	6,6	36



## Pump Ratings

-Q suffix pumps are for 700 bar torque wrenches, and include spin-on couplers.

-E suffix pumps are for use with Enerpac SQD and HXD 800 bar torque wrenches, and include polarized lock-ring safety couplers.

Page: 207



### Gauge Overlay Kit

Available separately for use with ZU4T-Series Classic: **GT-4015-Q** includes overlays for all S- and

W-Series torque wrenches.

**GT-4015** includes overlays for all SQD and HXD torque wrenches.

<sup>1)</sup> All models meet CE safety requirements and all CSA requirements.

<sup>2)</sup> European plug and CE EMC directive compliant

<sup>3)</sup> With NEMA 6-15 plug

<sup>4)</sup> Select -E suffixed pumps for Enerpac SQD and HXD 800 bar torque wrenches, see page 206.



# ZU4T-Series, Pump Options



## 4-Wrench Manifold

- For simultaneous operation of multiple torque wrenches
- Can be factory installed or ordered separately.

Accessory Kit * Model Nr.	Can be used on ZU4-Series torque wrench pumps
<b>ZTM-E</b>	for 800 bar torque wrenches
<b>ZTM-Q</b>	for 700 bar torque wrenches

\* Add suffix **M** for factory installation.

**Ordering Example: ZU4208TE-QM**



## Skid Bar

- Provides greater pump stability on soft or uneven surfaces
- Provides easy two-handed lift.

Accessory Kit * Model Nr.	Can be used on ZU4-Series torque wrench pumps
<b>SBZ-4</b>	4 and 6,6 litres reservoir <sup>1)</sup>
<b>SBZ-4L</b>	4 and 6,6 litres reservoir <sup>2)</sup>

\* Add suffix **K** to pump model number for factory installation.

<sup>1)</sup> Without heat exchanger 2,2 kg.

<sup>2)</sup> With heat exchanger 3,2 kg.

**Ordering Example: ZU4208TE-QK**



## Heat Exchanger

- Removes heat from the bypass oil to provide cooler operation
- Stabilizes oil viscosity, increasing oil life and reduces wear of pump and other hydraulic components.

Accessory Kit * Model Nr.	Can be used on ZU4-Series torque wrench pumps
<b>ZHE-U4</b>	4 and 6,6 litres reservoir

\* Add suffix **H** to pump model number for factory installation.

Heat Exchanger adds 4,1 kg to pump weight.

**Ordering Example: ZU4208TE-QH**

▼ Most hydraulic torque wrenches can be powered by the Enerpac ZU4-Series torque wrench pump.



## Roll Cage

- Protects pump
- Provides greater pump stability.

Accessory Kit * Model Nr.	Can be used on ZU4-Series torque wrench pumps
<b>ZRC-04</b>	4 and 6,6 litres reservoir <sup>1)</sup>
<b>ZRC-04H</b>	4 and 6,6 litres reservoir <sup>2)</sup>

\* Add suffix **R** for factory installation.

<sup>1)</sup> Without heat exchanger.

<sup>2)</sup> With heat exchanger.

**Ordering Example: ZU4208BE-QR**

Thermal Transfer *	Max. Pressure	Max. Oil Flow	Voltage
(Btu/h)	(bar)	(l/min)	(VDC)
900	20,7	26,5	12

\* At 1,9 l/min at 21 °C ambient temperature.

Do not exceed maximum oil flow and pressure ratings.

Heat exchanger is not suitable for water-glycol or high water-based fluids.

# ZU4T-Series, Ordering Matrix and Specifications

▼ This is how a ZU4T-Series pump model number is built up:

<b>Z</b>	<b>U</b>	<b>4</b>	<b>2</b>	<b>08</b>	<b>T</b>	<b>E</b>	<b>-</b>	<b>Q</b>	<b>H</b>	<b>M</b>
1	2	3	4	5	6	7		8	8	8
Product Type	Motor Type	Flow Group	Valve Type	Reservoir Size	Valve Operation	Voltage		Must be E or Q	Options	Options

## 1 Product Type

**Z** = Pump series

## 2 Motor Type

**U** = Universal electric motor

## 3 Flow Group

**4** = 1,0 l/min @ 700 bar

## 4 Valve Type

**2** = Torque wrench valve

## 5 Reservoir Size (useable oil)

**04** = 4,0 litres

**08** = 6,6 litres

## 6 Valve Operation

**T** = **Pro Serie pump** with solenoid valve and pendant, LCD Electric and pressure transducer

**B** = **Classic pump** with solenoid valve and pendant.

## 7 Voltage

**B** = 115V, 1 ph, 50/60 Hz

**E** = 208-240V, 1 ph, 50/60 Hz (with European plug CE RF compliant)

**I** = 208-240V, 1 ph, 50/60 Hz (with NEMA 6-15 plug)

## 8 Options

**E** = **800 bar coupler** for use with HXD and SQD-Series or other wrenches

**Q** = **700 bar coupler** for use with S and W-Series or other wrenches

**H** = Heat exchanger

**K** = Skid bar

**M** = 4-wrench manifold

**R** = Roll cage

## ZU4T Series



Reservoir Capacity:

**4,0 and 6,6 litres**

Flow at Rated Pressure:

**1,0 l/min**

Motor Size:

**1,25 kW**

Maximum Operating Pressure:

**700 and 800 bar**



**How to order your ZU4T-Series torque wrench pump**

### Ordering Example

**Model No. ZU4208TE-QMHK**

**700 bar Pro Serie pump** for use with Enerpac S and W-Series and other 700 bar torque wrenches, 230V motor, 6,6 litres reservoir, 4-wrench manifold, heat exchanger and skidbar.

Refer to the torque wrench pump selection matrix for optimum wrench, pump and hose combinations.

Page: 202

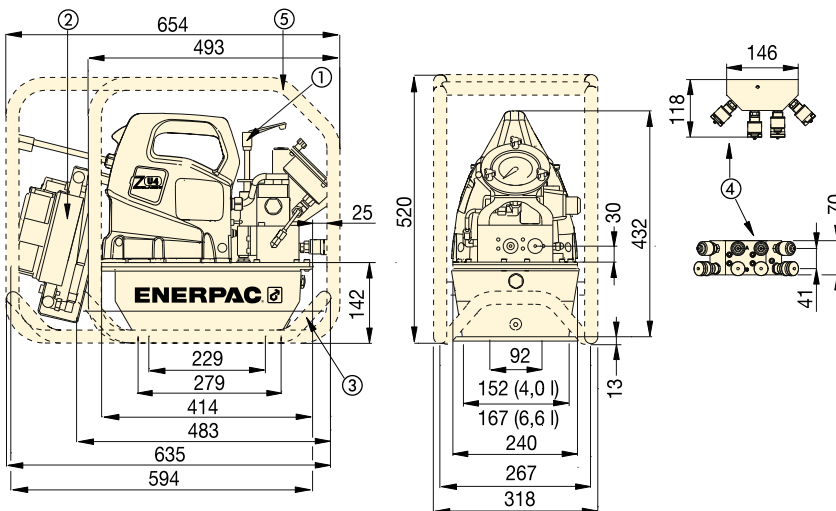

## ZU4T-Series Torque Wrench Pumps

- ① User adjustable relief valve
- ② Heat Exchanger (optional)
- ③ Skidbar (optional)
- ④ 4-wrench manifold (optional)
- ⑤ Roll cage (optional)

ZU4T-Series Performance Chart							
Motor Size (kW)	Output Flow Rate (l/min)				Motor Electrical Specification (Volt - Phase - Hz)	Sound Level (dBA)	Relief Valve Adjustment Range (bar)
	7 bar	50 bar	350 bar	700 bar			
1,25	11,5	8,8	1,2	1,0	115 - 1 - 50/60 208-240 - 1 - 50/60	85-90	124-700 *

\* Pump type (-Q) shown, (-E) range is 124-800 bar.



### Torque Wrench Hoses

Use Enerpac twin safety hoses to connect your torque wrench to the pump.

For 700 bar	Model-Nr.
6 m long, 2 hoses	<b>THQ-706T</b>
12 m long, 2 hoses	<b>THQ-712T</b>
For 800 bar	
6 m long, 2 hoses	<b>THC-7062</b>
12 m long, 2 hoses	<b>THC-7122</b>

▼ ZE4204TE-QHR



**Z** Tough,  
Dependable  
Innovative  
**CLASS**

- Auto-Cycle feature provides continuous cycle operation of the torque wrench as long as the advance button is pressed (pump can be used with or without auto cycle feature)
- LCD readout provides pressure and torque display and a number of diagnostic and readout capabilities never before offered on a portable electric pump
- Totally enclosed, fan-cooled industrial electric motors supply extended life and stand up to harsh industrial environments
- High-strength, molded electrical enclosure protects electronics, power supplies and LCD readout from harsh environments.



#### ZE4T and ZE5T-Series Torque Wrench Pumps

Back-lit LCD and Pressure Transducer featuring Auto-Cycle Technology.

- Digital read-out and “Auto-Cycle” setting
- Auto cycle” setting easily programmable.
- Torque wrench model is selectable
- Display torque in Nm or Ft.lbs
- Pump usage information, hour and cycle counts
- Low-voltage warning and recording
- Self-test and diagnostic capabilities
- Information can be displayed in English, French, German, Italian, Spanish and Portuguese
- Pressure transducer is more accurate and durable than analog gauges
- Easy-viewing variable rate display
- Display pressure in bar, MPa or psi.



◀ The ZE4T-Series torque wrench pumps are perfectly matched for this W2000 wrench.

# ZE-Series, Electric Torque Wrench Pumps

## ZE4T AND ZE5T-SERIES OIL FLOW VERSUS PRESSURE

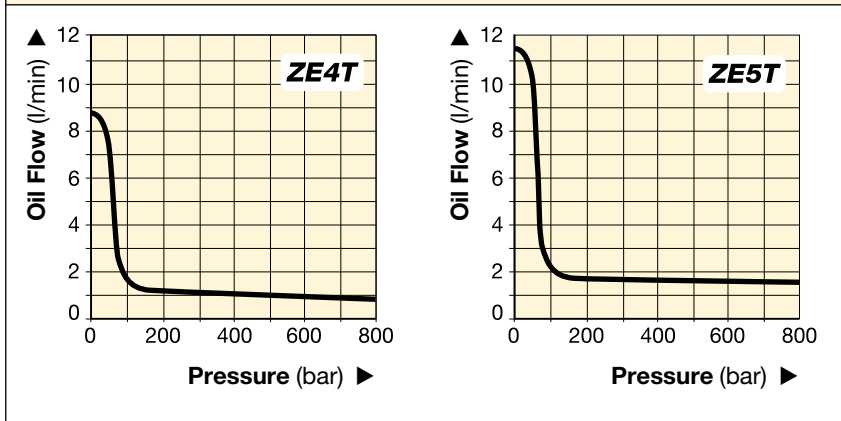

## ZE4T ZE5T Series



Reservoir Capacity:

**4,0 and 8,0 litres**

Flow at Rated Pressure:

**0,82 - 1,64 l/min**

Motor Size:

**1,1 - 2,2 kW**

Maximum Operating Pressure:

**700 and 800 bar**

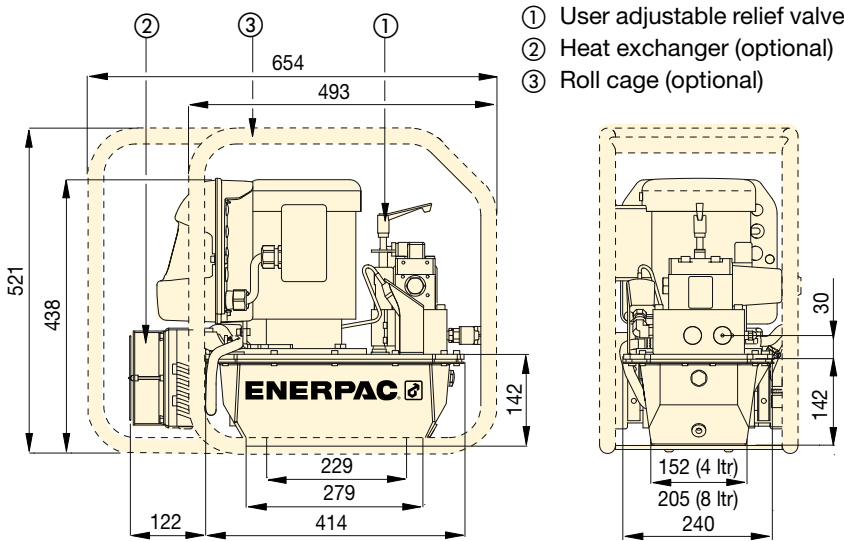

ZE4T and ZE5T-Series, 4 and 8 litres reservoirs

### ▼ COMMON TORQUE WRENCH PUMP MODELS

For Use With Torque Wrenches	Max. Operating Pressure (bar)	Model Number with Heat Exchanger and Roll Cage	Motor Electrical Specification (Volt - Ph - Hz)	Usable Oil Capacity <sup>1)</sup> (litres)	Weight (kg)
all S and W-Series	700	ZE4204TB-QHR	115 - 1 - 50/60	4,0	61
	700	ZE4204TE-QHR	230 - 1 - 50/60	4,0	61
	700	ZE4204TG-QHR	230 - 3 - 50/60	4,0	62
	700	ZE5204TW-QHR	400 - 3 - 50/60	4,0	62
all SQD and HXD-Series	800	ZE4204TB-EHR	115 - 1 - 50/60	4,0	61
	800	ZE4204TE-EHR	230 - 1 - 50/60	4,0	61
	800	ZE4204TG-EHR	230 - 3 - 50/60	4,0	62
	800	ZE5204TW-EHR	400 - 3 - 50/60	4,0	62

<sup>1)</sup> Larger reservoirs (8, 10, 20 and 40 litres) are available. Contact Enerpac.

### ▼ PERFORMANCE CHART

Pump Series	Output Flow Rate at 50 Hz <sup>2)</sup> (l/min)				Motor Size (kW)	Relief Valve Adjustment Range (bar)	Sound Level (dBA)
	7 bar	50 bar	350 bar	700 bar			
ZE4T	8,8	8,1	0,9	0,8	1,1	70 - 800	75
ZE5T	11,8	11,2	1,7	1,6	2,2	70 - 800	75

<sup>2)</sup> Flow rate will be approximately 6/5 higher at 60 Hz.



### Torque Wrench Pump Selection Matrix

For optimum speed and performance see the torque wrench pump and hose selection matrix.

Page: 202



### Torque Wrench Hoses

Use Enerpac twin safety hoses to connect your torque wrench to the pump.

For 700 bar	Model Nr.
6 m long, 2 hoses	THQ-706T
12 m long, 2 hoses	THQ-712T
For 800 bar	Model Nr.
6 m long, 2 hoses	THC-7062
12 m long, 2 hoses	THC-7122



▼ PTA-1404



- Compact and portable
- Handle located directly over pump's center of gravity for greater ease in carrying
- High bypass (125 bar) for faster torque cycles
- High power-to-weight ratio suits all Enerpac torque wrenches
- Glycerine filled pressure gauge with scales reading in bar/psi
- Transparent overlays in Nm and Ft.lbs for all Enerpac torque wrenches provide a quick torque reference
- Internal safety relief valve, factory preset.



## Two-Stage Power in a Portable Design



### Torque Wrench Hoses

Use Enerpac twin safety hoses to connect your torque wrench to the pump.

For 700 bar	Model Nr.
6 m long, 2 hoses	<b>THQ-706T</b>
12 m long, 2 hoses	<b>THQ-712T</b>
For 800 bar	
6 m long, 2 hoses	<b>THC-7062</b>
12 m long, 2 hoses	<b>THC-7122</b>



### Gauge Overlay Kit

Available separately for use with PTA-Series pumps: **GT-4015-Q** includes overlays for all S and

W-Series torque wrenches.

**GT-4015** includes overlays for all SQD and HXD torque wrenches.

◀ *Easy and reliable service and maintenance in the workshop with Enerpac steel wrenches powered by a pneumatic torque wrench pump.*

# Compact Pneumatic Torque Wrench Pump

**PTA Series**



Reservoir Capacity:

**3,8 litres**

Flow at Rated Pressure:

**0,33 l/min**

Air Consumption:

**1133 l/min**

Maximum Operating Pressure:

**700 - 800 bar**

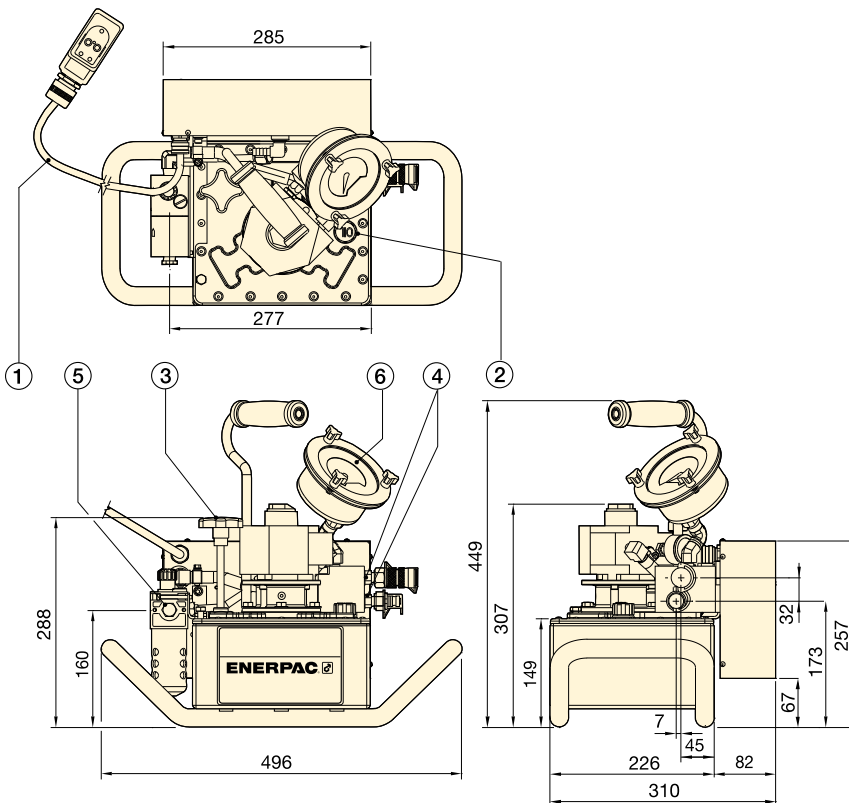

- ① 5 mtr Air control pendant
- ② Vent/Fill plug
- ③ Externally adjustable relief valve
- ④ 1/4"-18 NPTF Hydraulic ports
- ⑤ 3/8"-18 NPTF Air inlet
- ⑥ Gauge with overlay kit



### Torque Wrench Pump Selection Matrix

For optimum speed and performance see the torque wrench pump and hose selection matrix.

Page: 202

### OIL FLOW VERSUS PRESSURE

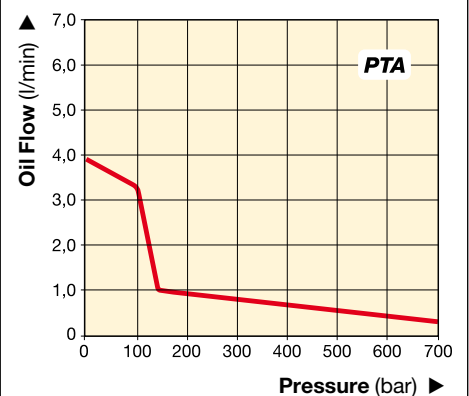

### ▼ PERFORMANCE CHART

For Use With Torque Wrenches		Pressure Rating		Model Number	Oil Flow Rate		Reservoir Capacity	Useable Oil	Air Consumption	Air Pressure Range	Weight
		1st stage	2nd stage		1st stage	2nd stage					
S1500 S3000	W2000 W4000	125	<b>700</b>	<b>PTA-1404-Q</b>	3,9	0,33	3,8	1,9	1133	3,4 - 7,0	24,5
SQD-25-I SQD-50-I	HXD-30 HXD-60	125	<b>800</b>	<b>PTA-1404</b>	3,9	0,33	3,8	1,9	1133	3,4 - 7,0	24,5

# ZA4T, Air Driven Torque Wrench Pumps

▼ ZA4204TX-ER



- Two-speed operation and high by-pass pressure reduces cycle time for improved productivity
- Glycerin filled pressure gauge with transparent overlays in Nm and Ft.lbs for Enerpac torque wrenches provide a quick torque reference
- Regulator-Filter-Lubricator with removable bowls and auto drain is standard
- Heat exchanger warms exhaust air to prevent freezing and cools the oil
- Ergonomic pendant allows remote operation up to 6 m.



**Z** Tough,  
Dependable  
Innovative  
**CLASS**



### Torque Wrench Hoses

Use Enerpac twin safety hoses to connect your torque wrench to the pump.

For 700 bar	Model Nr.
6 m long, 2 hoses	<b>THQ-706T</b>
12 m long, 2 hoses	<b>THQ-712T</b>
For 800 bar	
6 m long, 2 hoses	<b>THC-7062</b>
12 m long, 2 hoses	<b>THC-7122</b>



### Gauge Overlay Kit

Available separately for use with ZA4T-Series pumps: **GT-4015-Q** includes overlays for all S- and W-Series torque wrenches.

**GT-4015** includes overlays for all SQD and HXD torque wrenches.

◀ Most hydraulic torque wrenches can be powered by the Enerpac ZA4T-Series torque wrench pump.

# Air Driven Torque Wrench Pumps



## ZA4T-Series Pump Applications

The ZA4T-Series pump is best suited to power medium to large size torque wrenches.

Patent-pending **Z-Class** technology provides high by-pass pressures for increased productivity.

Its high power to weight ratio and compact design make it ideal for applications which require easy transport of the pump.

All ZA4T-Series pump models meet CE, CSA and TÜV safety requirements.

For further application assistance contact your local Enerpac office.

## ATEX 95 Certified

The ZA4T-Series pumps are tested and certified according to the **Equipment Directive 94 / 9 / EC "ATEX Directive"**.

The explosion protection is for equipment group II, equipment category 2 (hazardous area zone 1), in gas and/or dust atmospheres. The ZA4T-Series pumps are marked with: Ex II 2 GD ck T4.



## ZA4T Series



Reservoir Capacity:

**4,0 and 6,6 litres**

Flow at Rated Pressure:

**1,0 l/min**

Air Consumption:

**600 - 2840 l/min**

Maximum Operating Pressure:

**700 and 800 bar**

### OIL FLOW VERSUS PRESSURE

6,9 bar dynamic air pressure at 2840 l/min

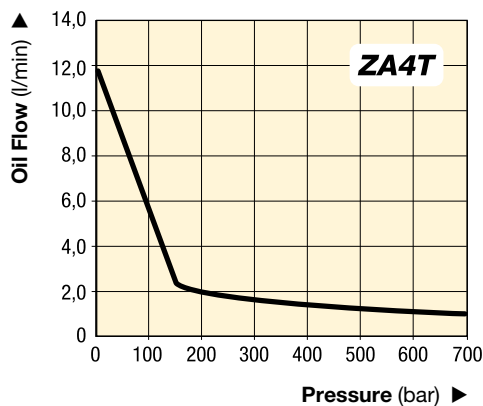

### Torque Wrench Pump Selection Matrix

For optimum speed and performance see the torque wrench pump and hose selection matrix.

Page: 202



### Accessory Options

Available by placing the following additional suffix at the end of the model number:

- K** = Skid bar
- M** = 4-wrench manifold
- R** = Roll cage.

Page: 214

### ▼ COMMON PUMP MODELS

For Use With Torque Wrenches		Maximum Operating Pressure (bar)	Model Number	Usable Oil Capacity (litres)	Weight (kg)
S1500 S3000 S6000 S11000 S25000	W2000 W4000	700	ZA4204TX-Q	4,0	42
		700	ZA4208TX-Q	6,6	47
	W8000 W15000	700	ZA4204TX-QR	4,0	46
		700	ZA4208TX-QR	6,6	51
SQD-75-I SQD-100-I SQD-160-I SQD-270-I	HXD-120 HXD-240	800	ZA4204TX-E	4,0	42
		800	ZA4208TX-E	6,6	47
		800	ZA4204TX-ER	4,0	46
		800	ZA4208TX-ER	6,6	51





### Skid Bar

- Provides greater pump stability on soft or uneven surfaces
- Provides easy two-handed lift.



### 4-Wrench Manifold

- For simultaneous operation of multiple torque wrenches
- Can be factory installed or ordered separately.



### Roll Cage

- Protects pump
- Provides greater pump stability

Accessory Kit * Model Nr.	Can be used on ZA4T-Series torque wrench pumps
<b>SBZ-4</b>	4,0 and 6,6 litres reservoir

\* Add suffix **K** for factory installation.  
Weight skid bar 2,2 kg.  
Ordering Example: **ZA4208TX-QK**

Accessory Kit * Model Nr.	Can be used on ZA4T-Series torque wrench pumps
<b>ZTM-E</b>	for 800 bar torque wrenches
<b>ZTM-Q</b>	for 700 bar torque wrenches

\* Add suffix **M** for factory installation.  
Weight manifold 4,5 kg.  
Ordering Example: **ZA4208TX-QM**

Accessory Kit * Model Nr.	Can be used on ZA4T-Series torque wrench pumps
<b>ZRC-04</b>	4,0 and 6,6 litres reservoir

\* Add suffix **R** for factory installation.  
Roll cage weight 3,4 kg.  
Ordering Example: **ZA4208TX-QR**



### 700 bar Spin-on Couplers

- Mounted on:
  - Torque wrench pumps with suffix "Q"
  - S and W-Series wrenches
  - THQ-Series hoses
  - 4-Wrench manifold ZTM-Q.



### 800 bar Lock-ring Couplers

- Mounted on:
  - Torque wrench pumps with suffix "E"
  - HXD and SQD-Series wrenches
  - THC-Series hoses
  - 4-Wrench manifold ZTM-E.



### Torque Wrench Hoses

Use Enerpac twin safety hoses to connect your torque wrench to the pump.

For 700 bar	Model Nr.
6 m long, 2 hoses	<b>THQ-706T</b>
12 m long, 2 hoses	<b>THQ-712T</b>
For 800 bar	
6 m long, 2 hoses	<b>THC-7062</b>
12 m long, 2 hoses	<b>THC-7122</b>



### Torque Wrench Couplers

For Enerpac torque wrench couplers see our "System Components" section in this catalogue.

# ZA4T-Series, Ordering Matrix and Specifications

▼ This is how a ZA4T-Series pump model number is built up:

<b>Z</b>	<b>A</b>	<b>4</b>	<b>2</b>	<b>08</b>	<b>T</b>	<b>X</b>	<b>-Q*</b>	<b>M</b>	<b>R</b>
1	2	3	4	5	6	7	8	8	8
Product Type	Motor Type	Flow Group	Valve Type	Reservoir Size	Valve Operation	Voltage	Must be E or Q	Options	Options

### 1 Product Type

**Z** = Pump series

### 2 Motor Type

**A** = Air motor

### 3 Flow Group

**4** = 1,0 l/min @ 700 bar

### 4 Valve Type

**2** = Torque Wrench Valve

### 5 Reservoir Size

(useable capacity)

**04** = 4,0 litres

**08** = 6,6 litres

### 6 Valve Operation

**T** = Air operated valve with pendant

### 7 Voltage

**X** = Not applicable

### 8 Options

**E** = **800 bar couplers** for use with HXD and SQD-Series or other wrenches

**Q** = **700 bar couplers** for use with S and W-Series or other wrenches

**K** = Skid bar

**M** = 4-wrench manifold

**R** = Roll cage

## ZA4T Series



Reservoir Capacity:

**4,0 and 6,6 litres**

Flow at Rated Pressure:

**1,0 l/min**

Air Consumption:

**600 - 2840 l/min**

Maximum Operating Pressure:

**700 and 800 bar**



**How to order your ZA4T-Series torque wrench pump**

### Model No. ZA4208TX-QMR

**700 bar** pump for use with Enerpac S- and W-Series and other 700 bar torque wrenches, 6,6 litres reservoir, 4-wrench manifold, and roll cage.

Refer to the torque wrench pump selection matrix for optimum wrench, pump and hose combinations.

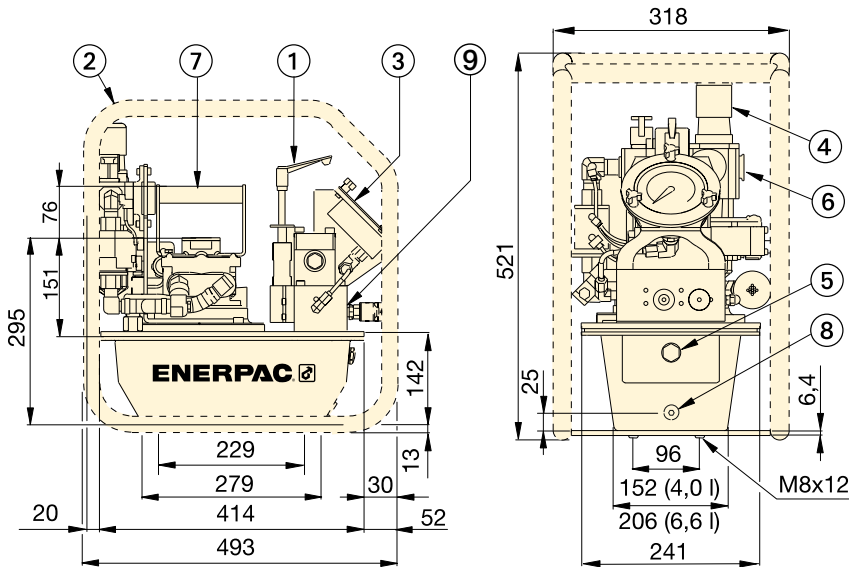

- ① User adjustable relief valve
- ② Roll Cage (optional)
- ③ Gauge with overlays
- ④ Filter/lubricator/regulator
- ⑤ Oil level sight gauge
- ⑥ Air input 1/2" NPTF
- ⑦ Standard handle
- ⑧ Oil drain
- ⑨ 1/4"-18 NPTF Oil outlet

ZA4T-Series Performance							
Output Flow Rate (l/min)				Dynamic Air Pressure Range (bar)	Air Consumption (l/min)	Sound Level (dBA)	Relief Valve Adjustment Range (bar)
7 bar	50 bar	350 bar	700 bar				
11,5	8,8	1,2	1,0	4,0 - 6,9	600 - 2840	85-90	124-700 *

\* Pump type (-Q) shown, (-E) range is 124-800 bar.

▼ Most hydraulic torque wrenches can be powered by the Enerpac ZA4T-Series torque wrench pump.



# ATM-Series, Flange Alignment Tools

▼ From left to right: **ATM-3, ATM-1, ATM-5** (shown without pump and hose)



- Rectifies twist and rotational misalignment without additional stress in pipe lines
- For most commonly used ANSI, API, BS and DIN flanges
- No slings, hooks, or lifting gear. Extremely safe, high precision
- ATM-1 supplied with three bushings for different bolt hole sizes. Can be used in reversed position
- ATM-3 fits on the following flanges:
  - Ring Type Joints: flange wall thickness min 30 - max 100 mm
  - Gasket Type Joints: flange wall thickness min 25 - max 115 mm
- ATM-5 Fits when flange joint is:
  - between 93 - 228 mm [3.75 - 9 inch] apart and
  - bolt hole size 31,5 mm [1.25 inch] or greater
- Can be installed and used in any position and any location
- Stays stable in position under full load.

▼ The Enerpac ATM-3 used to align a large ANSI flange.



## ATM Series

Minimum Bolt Hole Size:  
**17 - 54 mm / 1<sup>1</sup>/<sub>16</sub> - 2<sup>1</sup>/<sub>8</sub>"**

Flange Wall Thickness:  
**17 - 203 mm / 1<sup>1</sup>/<sub>16</sub> - 8"**

Maximum Lifting Force:  
**0,3 - 5,0 ton**



### Adjustable reach on ATM-3

The highly adjustable reach of the wing, the reversible lift hook and manual torque wrench **TW-22** allow precise alignment.



### ATM-5 including hydraulics

Including 700 bar hydraulics: RC-53 single-acting cylinder, P-142 two-speed hand pump and 1,8 meters long safety hose (HC-7206C).

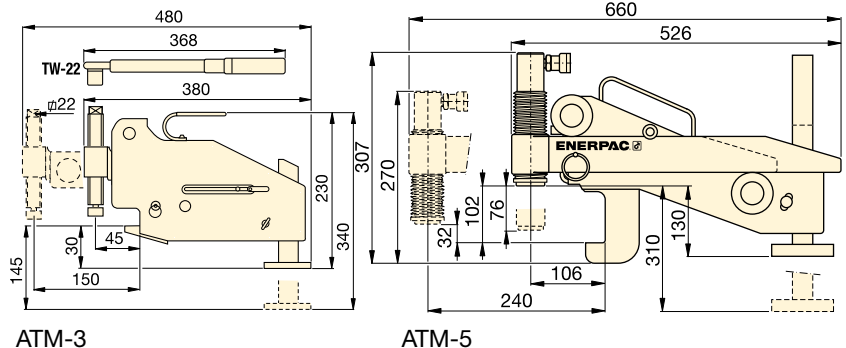
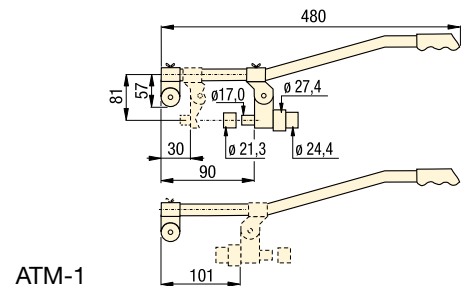

Maximum Lifting Force ton (kN)	Model Number	Bolt Hole Range		Flange Wall Thickness		 (kg)
		(mm)	(inch)	(mm)	(inch)	
0,3 (3)	<b>ATM-1</b>	17 - 27,2	1 <sup>1</sup> / <sub>16</sub> - 1 1 <sup>1</sup> / <sub>8</sub>	17 - 50	1 <sup>1</sup> / <sub>16</sub> - 2	2,0
3,0 (27)	<b>ATM-3</b>	25 - 54	1 - 2 1 <sup>1</sup> / <sub>8</sub>	30 - 115	1 3 <sup>3</sup> / <sub>16</sub> - 4 1 <sup>1</sup> / <sub>2</sub>	9,7
5,0 (45)	<b>ATM-5 *</b>	≥ 31,5	≥ 1 1 <sup>1</sup> / <sub>4</sub>	80-203	3 1 <sup>1</sup> / <sub>8</sub> - 8	16,2

\* At 700 bar maximum operating pressure.  
ATM-5 weight including hydraulic cylinder. Total set weight 28,2 kg.



# Hydraulic and Mechanical Wedge Spreaders

▼ FSH-14 and FSM-8 with safety blocks SB-1



- For maintenance, commissioning, shutdowns, testing and valve change outs
- Integrated wedge concept: Friction-free, smooth and parallel wedge movement eliminates flange damage and spreading arm failure
- Unique interlocking wedge design - no first step bending and risk of slipping out of joint
- Requires very small access gap of only 6 mm
- Stepped spreader arm design - each step can spread under full load
- Few moving parts mean durability and low maintenance
- Safety block SB-1 and ratchet spanner SW-22 included with FSM-8 mechanical wedge spreader
- Safety block SB-1 and Enerpac RC-102 single-acting cylinder included with FSH-14 hydraulic wedge spreader.

## FSH, FSM, STF Series

Tip Clearance / Maximum Spread <sup>1)</sup>:  
**6 mm / 80 mm**

Maximum Spread Force:  
**8 - 14 ton**

Maximum Operating Pressure:  
**700 bar (FSH-14)**



### Stepped Blocks FSB-1

Use stepped blocks to increase wedge opening up to 80 mm. Fits both FSH-14 and FSM-8.



### Control Manifolds

For simultaneously and even spreading of flange joints, 180° apart with FSH-14.

Page: 124

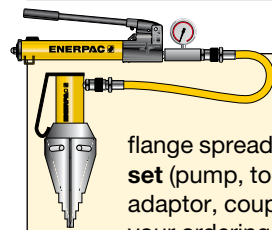

### Tool-Pump Sets

The hydraulic flange spreader is available as set (pump, tool, gauge adaptor, couplers and hose) for your ordering convenience.

Spreader Model Nr.	Handpump Model Nr.	Set Model Number
FSH-14	P-392	STF-14H

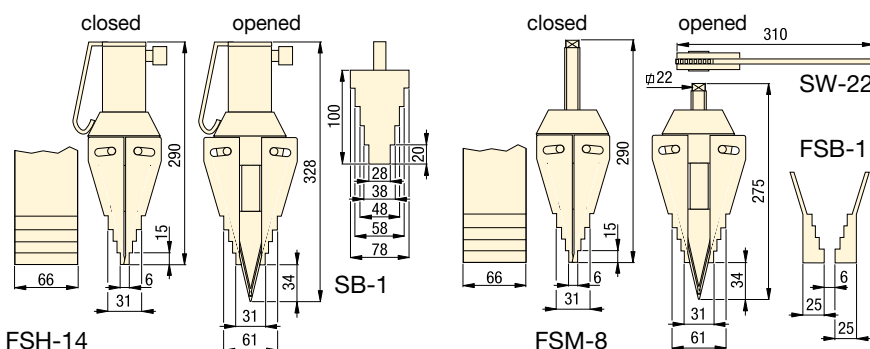

▼ Two FSH-14 spreaders used simultaneously with Enerpac handpump, hoses and AM-21 control manifold.



Maximum Spreading Force ton (kN)	Model Number	Tip Clearance (mm)	Maximum Spread <sup>1)</sup> (mm)	Spreader Type	Oil Capacity (cm <sup>3</sup> )	Weight (kg)
14 (125)	FSH-14*	6	80	Hydraulic	78	7,1
8 (72)	FSM-8	6	80	Mechanical	-	6,5

<sup>1)</sup> Using stepped blocks FSB-1

\* Available as pump-tool set, see note on this page.



# FS-Series, Hydraulic Flange Spreaders

▼ Shown: FS-56



- Lightweight, ergonomic design for ease of use
- Adjustable jaw widths from 70 mm to 216 mm for a wide range of applications
- Single-acting, spring return RC-Series cylinders for fast trouble-free operation.

## FS, STF Series



Capacity:  
**5 and 10 ton**

Spread:  
**70 - 216 mm**

Maximum Operating Pressure:  
**700 bar**

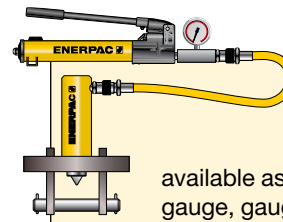

### Tool-Pump Sets

Both Flange Spreaders are available as **sets** (pump, tool, gauge, gauge adaptor, couplers and hose) for your ordering convenience.

Spreader Model Nr.	Pump Model Nr.	Set Model Number
FS-56	P-392	<b>STF-56H</b>
FS-109	P-392	<b>STF-109H</b>
FS-109	PATG-1102N	<b>STF-109A</b>



### Wedge Spreaders

Friction-free, smooth and parallel wedge movement with unique interlock wedge design. Eliminates flange damage and risk of spreading arm failure.

Page: **217**

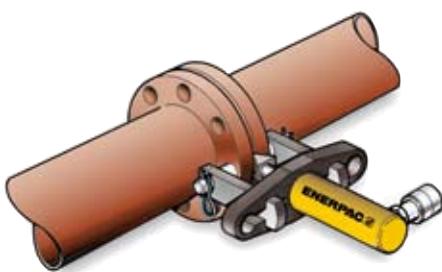
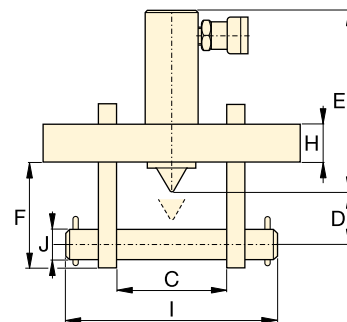
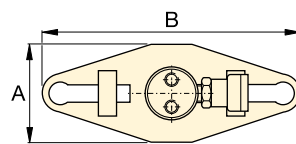

### Flange Spreader Matching Chart

ASA Rating (bar)	Pipe Size (mm)	
	FS-56	FS-109
<b>10</b>	127 - 508	558 - 1066
<b>20</b>	63 - 355	406 - 711
<b>27</b>	63 - 304	355 - 609
<b>35</b>	63 - 254	304 - 508
<b>62</b>	12 - 152	203 - 406
<b>103</b>	12 - 88	101 - 203
<b>172</b>	12 - 63	76 - 101

Maximum Flange Thickness (mm)	Stud Size (mm)	Standard Wedge (mm)	Capacity (ton)	Stroke (mm)	Oil Capacity (cm <sup>3</sup> )	Model Number	Dimensions (mm)										 (kg)
							A	B	C		D	E	F	H	I	J	
									Min.	Max.							
2 x 57	19 - 28	3 - 28	5	38	24,6	<b>FS-56*</b>	76	209	70	155	32	196	88	25	206	19	11,5
2 x 92	31 - 41	3 - 28	10	54	78,7	<b>FS-109*</b>	108	279	104	216	50	152	114	38	273	31	18,1

\* Available as Tool-Pump Set, see note on this page.

# Single-Acting Hydraulic Nut Splitters

▼ Shown from left to right: NC-3241, NC-1319, NC-1924



- Compact and ergonomic design, easy to use
- Unique angled head design
- Single-acting, spring return cylinder
- Heavy duty chisels can be reground
- Nut Splitters include spare chisel, spare set screw and wrench used to secure the chisel. A CR-400 coupler is standard.
- Applications include service trucks, piping industry, tank cleaning, petrochemical, steel construction, mining, etc.



◀ Easily removing rusty nuts during railroad construction is just one of many application examples for the Enerpac Nut Splitter.

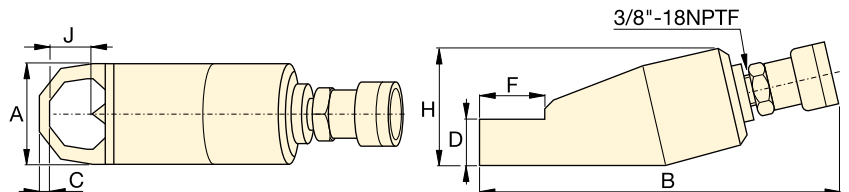

## NC, STN Series



Capacity:

**49 - 882 kN (5-90 ton)**

Bolt Range:

**M6 - M48**

Maximum Operating Pressure:

**700 bar**

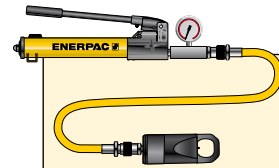

### Tool-Pump Sets

Hydraulic Nut Splitters are available as

sets (pump, tool, gauge, gauge adaptor, couplers and hose) for your ordering convenience.

Nut Splitter Model Nr.	Hand Pump Model Nr.	Set Model Nr
NC-1924	P-392	<b>STN-1924H</b>
NC-2432	P-392	<b>STN-2432H</b>
NC-3241	P-392	<b>STN-3241H</b>



### NS-Series, Nut Splitters

For splitting hexagon nut sizes from 70 - 130 mm see our high performance nut splitters.

Page: 220

Bolt Range (mm)	Hexagon Nut Range (mm)	Capacity ton (kN)	Oil Capacity (cm <sup>3</sup> )	Model Number	Dimensions (mm)							Replacement Chisel Model Number	
					A	B	C	D	F	H	J		
M6 - M12	10 - 19	5 (49)	15	NC-1319	40	170	7	19	28	48	21	1,2	NCB-1319
M12 - M16	19 - 24	10 (98)	20	NC-1924 *	54	191	10	26	40	62	25	2,0	NCB-1924
M16 - M22	24 - 32	15 (147)	60	NC-2432 *	64	222	13	29	51	72	33	3,0	NCB-2432
M22 - M27	32 - 41	20 (196)	80	NC-3241 *	75	244	17	36	66	88	43	4,4	NCB-3241
M27 - M33	41 - 50	35 (343)	155	NC-4150	94	288	21	45	74	105	54	8,2	NCB-4150
M33 - M39	50 - 60	50 (490)	240	NC-5060	106	318	23	54	90	128	60	11,8	NCB-5060
M39 - M48	60 - 75	90 (882)	492	NC-6075	156	393	26	72	110	181	80	34,1	NCB-6075

\* Available as Tool-Pump Set, see note on this page.

Ordering Notes: Maximum allowable hardness to split is HRc-44. Not to be used on square nuts.

▼ Shown: NS-Series Hydraulic Nut Splitters



- Specially designed to suit standard ANSI B16.5 / BS1560 flanges
- Single-acting (spring return) or double-acting cylinder
- Tri-blade technology provides three cutting surfaces on a single blade
- Interchangeable heads provide maximum nut range flexibility
- Preset scale allows controlled blade extension, which avoids damage to bolt threads
- Grip tape and handle included for more secure manoeuvrability
- Nickel-plated cylinder body for excellent corrosion protection and improved durability in harsh environments
- Internal Pressure Relief Valve for overload protection
- CR-400 coupler and dustcap included on all models.



◀ Heavily corroded and weathered nuts are quickly split and removed using a NS-Series Nutsplitter.

## Power and Precision High Performance Nut Splitter



### Blade Cutting Depth Scale

Adjustable cutting depth scale for controlled blade extension, which avoids damage to bolt threads.

The scale indicates the bolt range in metric and imperial values on each cutting head.



### NC-Series, Hydraulic Nut Cutters

The NC-Series models are available featuring an angle-head design for 10 - 75 mm hexagon nuts.

Page: 219



### Joint Separation Tools

FS and FSH-Series parallel wedge spreaders provide quick and easy joint separation using hydraulic or mechanical force.

Page: 217







### Flange Alignment Tools

The ATM-Series provide safe and high-precision flange alignment tools that fit most commonly used ANSI, API, BS and DIN flanges.

Page: 216

# Single and Double-Acting Hydraulic Nut Splitters

## ▼ NUT SPLITTER SELECTION CHART

Bolt Range* (mm)	Model Number 	Hydraulic Cylinder Type <sup>1)</sup>		Components included		
		SA	DA	Hydraulic Cylinder 	Cutting Head 	Replacement Blade 
M45 - M52	NS-7080	●		NSC-70	NSH-7080	NSB-70
M45 - M52	NS-7080D		●	NSC-70D	NSH-7080	NSB-70
M45 - M56	NS-7085	●		NSC-70	NSH-7085	NSB-70
M45 - M56	NS-7085D		●	NSC-70D	NSH-7085	NSB-70
M45 - M64	NS-7095	●		NSC-70	NSH-7095	NSB-70
M45 - M64	NS-7095D		●	NSC-70D	NSH-7095	NSB-70
M45 - M72	NS-70105	●		NSC-70	NSH-70105	NSB-70
M45 - M72	NS-70105D		●	NSC-70D	NSH-70105	NSB-70
M76 - M80	NS-110115	●		NSC-110	NSH-110115	NSB-110
M76 - M80	NS-110115D		●	NSC-110D	NSH-110115	NSB-110
M76 - M90	NS-110130	●		NSC-110	NSH-110130	NSB-110
M76 - M90	NS-110130D		●	NSC-110D	NSH-110130	NSB-110

<sup>1)</sup> SA = Single-Acting; DA = Double-Acting.

## NS Series



Capacity:

**917 - 1711 kN**

Hexagon Nut Size:

**70 - 130 mm**









Bolt Range:

**M45 - M90**

Maximum Operating Pressure:

**700 bar**

## ▼ TOOL-PUMP SET SELECTION CHART

Single-Acting Nut Splitter Model Nr.	Tool-Pump Set Model Nr.	Pump Selection <sup>2)</sup>			Accessories Included			
		Hand Pump Model Nr.	Air Pump Model Nr.	Electric Pump Model Nr.	Pressure Gauge Model Nr.	Gauge Adaptor Model Nr.	Hydraulic Hose Model Nr.	Storage Case Model Nr.
								
NS-70105	NS-70105SH	P-392	-	-	GP-10S	GA-2	HC-7206	CM-4
NS-70105	NS-70105SA	-	XA-11G	-	<sup>3)</sup>	-	HC-7206	CM-4
NS-70105	NS-70105SEE	-	-	PUD-1100E	GP-10S	GA-2	HC-7206	CM-7
NS-110130	NS-110130SH	P-802	-	-	GP-10S	GA-2	HC-7206	CM-4
NS-110130	NS-110130SA	-	XA-11G	-	<sup>3)</sup>	-	HC-7206	CM-4
NS-110130	NS-110130SEE	-	-	PUD-1100E	GP-10S	GA-2	HC-7206	CM-7

<sup>2)</sup> For operating double-acting nut splitters Enerpac recommend **P-842** hand pump, **XA-12VG** air pump or **PUJ-1400E** electric pump and two HC-7206 hoses.

<sup>3)</sup> XA-11G air pump features an integrated pressure gauge.

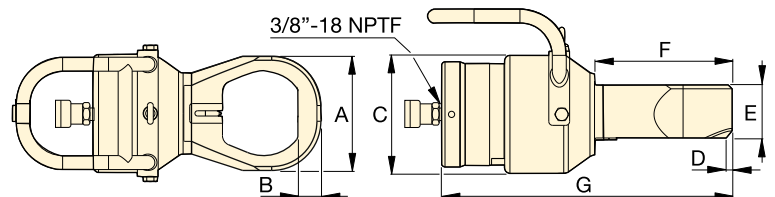

## ▼ NUT SPLITTER SPECIFICATIONS

Bolt Range <sup>4)</sup> (mm)	Hexagon Nut Range <sup>4)</sup> (mm)	Capacity ton (kN)	Oil Capacity (cm <sup>3</sup> )	Model Number <sup>5)</sup> Single-Acting	Model Number <sup>5)</sup> Double-Acting	Dimensions (mm)							 (kg)
						A	B	C	D	E	F	G	
M45 - M52	70 - 80	103 (917)	377	NS-7080	NS-7080D	132	28	180	8,0	81	186	412	37,0
M45 - M56	70 - 85	103 (917)	377	NS-7085	NS-7085D	145	30	180	8,0	81	196	422	37,0
M45 - M64	70 - 95	103 (917)	377	NS-7095	NS-7095D	160	32	180	8,0	81	201	432	38,5
M45 - M72	70 - 105	103 (917)	377	NS-70105	NS-70105D	174	35	180	9,0	81	209	443	39,5
M76 - M80	110 - 115	917 (1711)	819	NS-110115	NS-110115D	189	36	234	3,7	111	234	472	69,0
M76 - M90	110 - 130	917 (1711)	819	NS-110130	NS-110130D	219	41	234	2,5	111	242	493	71,5

<sup>4)</sup> Maximum allowable hardness to split is HRC-44. See page 254 for hexagon bolt and nut sizes and related thread diameters.

<sup>5)</sup> NS-Series Nut Splitters ship in two cases: One containing the NSC-Cylinder and one containing the NSH-Cutting Head. Assembly required.



With more than 50 years of experience, Enerpac has gained unique expertise which is acknowledged by industrial and construction professionals around the world. In addition to standard products and components, Enerpac specializes in the design, manufacture and supply (sale & rental) of high-force hydraulic systems required for the precise controlled movement of heavy structures.

Engineers and construction experts consult with Enerpac to develop integrated hydraulic solutions, which have included:







- The incremental launching equipment for the tallest bridge in the world – le Viaduct de Millau (France),
- Construction solutions for the China Olympics – Beijing’s National Stadium, the world’s largest steel structure and the retractable roof system for the Nantong Olympic Stadium.
- Automatic foundation leveling systems for offshore wind turbines,
- Strand jacking equipment for construction, oil & gas and industrial heavy lifting applications.

Across every continent Enerpac has presence through local offices, including application engineers, authorized distributors and service centers to deliver innovative solutions and technical assistance.

The deciding factor to choose for Enerpac resides on a history of supply of quality products & systems as well as a strong relationship with customers, Enerpac local representation and an excellent back-up in technical support on a global front.



# Integrated Solutions Section Overview

Capacity ton (kN)	Capabilities	Series	Page
N/A	<b>Synchronous Lifting Systems</b> Standard 4 to 16 point lift system	ESS	 <b>224</b> ▶
N/A	<b>Synchronous Lifting Systems</b> Premium 4 to 64 point lift system	EPS	 <b>226</b> ▶
<b>37 - 673</b> (360 - 6600)	<b>Heavy Lifting Strand Jack Systems</b> Accurate lifting, lowering or horizontal movements of heavy loads	TT	 <b>228</b> ▶
<b>5,5 - 37 kW</b>	<b>Strand Jack Hydraulic Pumps</b> <b>Master PLC-Control Units</b> Control multiple strand jacks & pumps	TTP	 <b>230</b> ▶ <b>231</b> ▶
<b>50 - 200</b> (498 - 1995)	<b>Stage Lifting Systems</b> Incremental lifting	BLS	 <b>232</b> ▶
<b>60 - 110</b> (605 - 1110)	<b>Synchronous Hoisting Systems</b> SyncHoist – hydraulic precision positioning systems	SHS	 <b>234</b> ▶
<b>0,25 - 250</b> (2,2 - 2222)	<b>Uni-Lift® Actuators</b> Mechanical precision positioning	M B	 <b>236</b> ▶

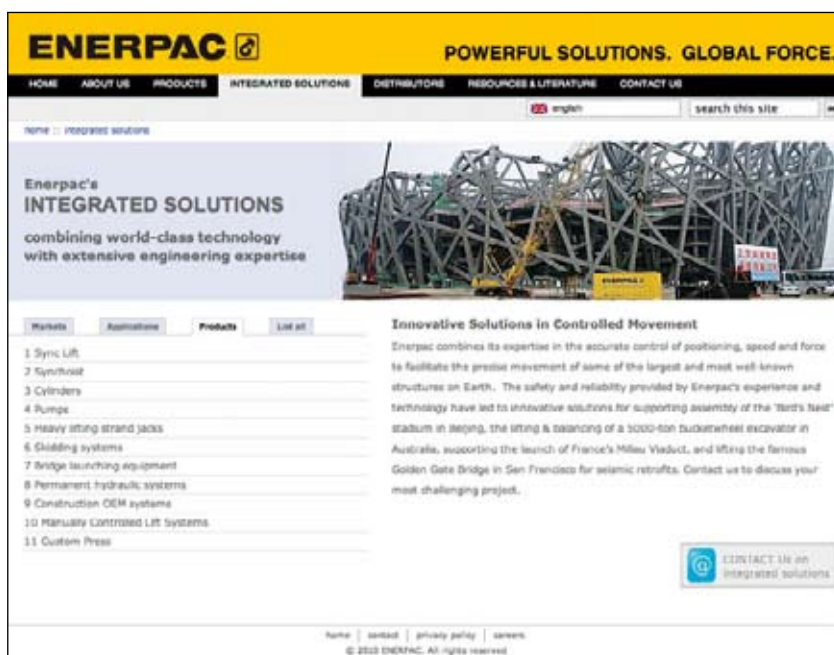

## Contact Enerpac!

Contact the Enerpac office nearest to you for advice and technical assistance in the layout of your ideal Lifting System or visit us at: [www.enerpac.com](http://www.enerpac.com).

Or ask Enerpac for assistance by email: [integratedsolutions@enerpac.com](mailto:integratedsolutions@enerpac.com).

# Standard 4 to 16 Point Lifting System

▼ **ESS-Series 8-point Synchronous Lifting System** (shown without cylinders)



- **Stroke and load controlled movement for positioning and weighing**
- **Measurement accuracy better than 1,0 mm between leading and lagging cylinders**
- **Data storage and recording capabilities**
- **Load and stroke alarms for optimal safety**
- **For use with standard single or double-acting cylinders**
- **Integrated 700 bar hydraulic pump and controls.**



▼ *Synchronous system lifted and monitored the load of the bridge as pier heads were rebuilt for wider traffic lanes, while highway below and the railway on top of this bridge were kept operational.*



## Controlled Hydraulic Movement for Positioning and Weighing



### Typical Synchronous Lifting Applications

- Lifting, lowering, weighing of heavy structures
- Centre of gravity measurement
- Bridge maintenance
- Deck lifting & bearing replacement
- De-propping/load transfer from temporary steel work
- Heavy plant installation
- Incremental bridge launching & box jacking
- Pile testing
- Foundation shoring.



### Contact Enerpac!

Contact the Enerpac office nearest to you for advice and technical assistance in the layout of your ideal Lifting System or visit us at: [www.enerpac.com](http://www.enerpac.com).

Or ask Enerpac for assistance by email: [integratedsolutions@enerpac.com](mailto:integratedsolutions@enerpac.com).



### Lifting Cylinders

For a complete line of Enerpac cylinders, see the Cylinder and Lifting Products Section of this catalogue.

Page: **5**



### Premium Synchronous Lifting Systems

For networking, data storage, preprogrammable and recording functions, graphical representation and up to 64 lifting points see the **EPS-Series** Synchronous Lifting System.

Page: **226**



# Standard 4 to 16 Point Synchronous Lifting System



## Synchronous Lifting

The synchronous lift system uses feedback from multiple sensors to control the lifting, lowering and positioning of any large, heavy or complex structure, regardless of weight distribution.

Synchronous lifting reduces the risk of bending, twisting or tilting, due to uneven weight distribution or load-shifts between the lift points.

A PLC controller monitors each lift position stroke and optional load transducers located at each lift point. By varying the oil flow to each lift point, the system maintains very accurate positional control.

This control maintains structural integrity and can increase the productivity and safety of the lift, by eliminating manual intervention in the event of a load-shift or other problem.

Programmable and failsafe monitoring and safety alarms include operating parameters and hydraulic conditions, such as oil-level and over-temperature.

Programmable data recording and "differential-lift" options allow a load to be manipulated into a pre-set position.

## ESS Series



Number of Lifting Points:  
**4, 8, 12 or 16**

Accuracy Over Full Stroke:  
**± 1,0 mm**

Maximum Operating Pressure:  
**700 bar**



### ▼ Touch screen display of ESS-Series synchronous lifting PLC-controller

The screenshot shows a control interface with the following elements:

- ① Total Load: 0000.0 KN
- Selected Load: 0000.0 KN
- ③ Absolute Position: 0000.0 mm
- ④ Relative Position: 0000.0 mm
- ⑤ Load: 0000.0 KN
- Real Position: 0000.0 mm
- Relative Position: 0000.0 mm
- Load: 0000.0 KN
- ⑥ MANUAL, SYNCHRO POSITION, LOAD MODE, RESET POSITION buttons
- ⑦ Delta Position: 0000.0 mm
- ⑧ Final Load: 0000.0 KN
- ⑨ Relative position reset button

▲ PLC-controller station for ESS-Series synchronous lifting system.

▼ Offshore wind turbines levelling in the North Sea, Germany: Enerpac's hydraulic synchronous lifting system provided the solution for levelling the supporting cross pieces for 80 wind turbines of 5 MW each.



### ▼ Typical layout for a 4-point ESS-Series synchronous lifting system

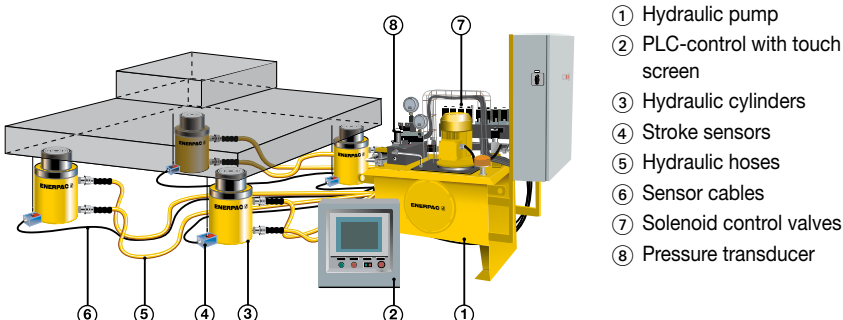



# Premium 4 to 64 Point Lifting System

## ▼ EPS-Series 4-point Premium Synchronous Lifting System



- Controls up to 64 lifting points
- Networking available to connect multiple systems
- Stroke, load and tilt controlled movement
- Hydraulic weighing and centre of gravity functions
- Dynamic load or stroke compensation
- Load and stroke alarms for optimal safety
- Pre-programmable movement
- Measurement accuracy better than  $\pm 0,25$  mm between leading and lagging cylinders
- Data storage, recording capabilities and graphic representation available
- For use with standard single- or double-acting cylinders
- Integrated 700 bar hydraulic pump and controls.



**Ideal for lifting applications requiring customised control features**



### Lifting an Unbalanced Load

Visit [www.enerpac.com](http://www.enerpac.com) to learn more about hydraulics and system set-ups.



### Contact Enerpac!

Contact the Enerpac office nearest to you for advice and technical assistance in the layout of your ideal Lift System. You can also ask Enerpac for assistance by email at: [integratedsolutions@enerpac.com](mailto:integratedsolutions@enerpac.com).



### EPS-Series Premium Synchronous Lifting Systems

The potential applications of this system are numerous. Synchronised lifting, lowering, pushing, pulling and positioning using computer technology and high-pressure hydraulics has become popular in many industries around the world.

The lifting or lowering capacity of this system is unlimited. By adding more or larger hydraulic cylinders to the setup, the system will allow jobs of 50.000 ton and more to be lifted with a high-level of safety and accuracy.

◀ Hydraulic lifting, weighing and manipulation system. During the lifting procedure the 16 point synchronous system operates within strict load and stroke constraints to ensure the desired load paths into the ship's hull structure are maintained. The various ship's hull segments up to 1300 tons are supported by the premium synchronous lifting system to confirm the design calculations.

# Premium 4 to 64 Point Synchronous Lifting System

▼ In tilting mode, each cylinder can be programmed to achieve a different stroke at the same time.

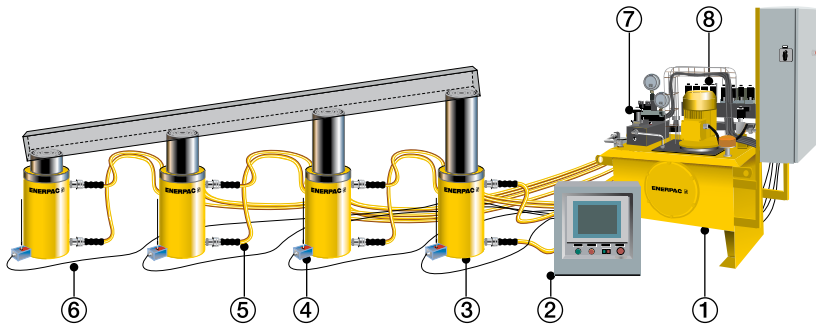

- ① Hydraulic pump
- ② PLC-control with touch screen
- ③ Hydraulic cylinders
- ④ Stroke sensors
- ⑤ Hydraulic hoses
- ⑥ Sensor cables
- ⑦ Solenoid control valves
- ⑧ Pressure transducer

## EPS Series



Number of Lifting Points:  
**4 to 64**

Accuracy Over Full Stroke:  
**± 0,25 mm**

Maximum Operating Pressure:  
**700 bar**

▼ Touch screen display of EPS Synchronous Lift Controller.

- ① Operating Mode
- ② Load Reading
- ③ Cylinder On/Off
- ④ Absolute Sensor Position
- ⑤ Relative Sensor Position
- ⑥ Individual Load Readings
- ⑦ Tilting Control Values
- ⑧ Operating Mode Selection
- ⑨ Manual Controls
- ⑩ Speed Control
- ⑪ Auto Control Values
- ⑫ Recording Controls
- ⑬ Relative Position Reset



▲ PLC-controller station of the EPS-Series premium synchronous lifting system.

▼ One of the world's first and largest lifting jobs for maintenance of a 3500 ton mining dragline was successfully done with an Enerpac synchronous hydraulic system: exact aligning of bearings on the rail on which this dragline rotates.



▼ Millau Viaduct, France: Bridge lifting and launching system. The load is balanced on groups of CLL-Series lock nut cylinders. The hydraulic lifting, launching and balancing movements are synchronised with PLC-control.





# TT-Series, Heavy Lifting Strand Jacks

▼ Shown: TT-84SJ706, 86 ton Strand Jack



- Hydraulic wedge setting and wedge release for positive load control
- Individual strand guidance through jack
- Multi functional treatment for corrosion protection and trouble-free wedge release
- Jacks designed to be operated in all positions: vertical, horizontal or inclined
- Strand jack designed according to the highest safety standards with a minimum of 2,5:1 of strand breaking load
- Built-in sensors for closed-loop control.

▼ Heavy lifting system with 11 x 3720 kN Strand Jacks, 6 pumps, a master PLC-control system and network, for lifting roofs during the construction of a new triple bay aircraft maintenance hangar at Abu Dhabi International Airport.



## Lifting, lowering or horizontal movements of heavy loads



### Lifting in Unusual Situations

When loads need to be lifted or lowered in tight areas or in situations where overhead clearance is limited, Enerpac offers this economical alternative to traditional rigging equipment. Contact Enerpac: [integratedsolutions@enerpac.com](mailto:integratedsolutions@enerpac.com).



### Pre-stress Cap

Included with all strand jacks. Used for tensioning strand prior to operation.



### Strand Wedges

Specially designed wedges for use with Enerpac strand jacks are included and available to purchase separately.



### Heavy Lifting Accessories

- Lifting attachments
- Palm trees
- Strand recoilers
- Strand dispenser.

▼ Eight 444 ton strand jacks including palm trees, lifting attachments, strand recoilers and lifting wedge consumables will lift twelve ball mills weighing 1500 ton to a height of 20 metres onto their bearing housings at an Australia mining facility.



# Heavy Lifting Strand Jacks

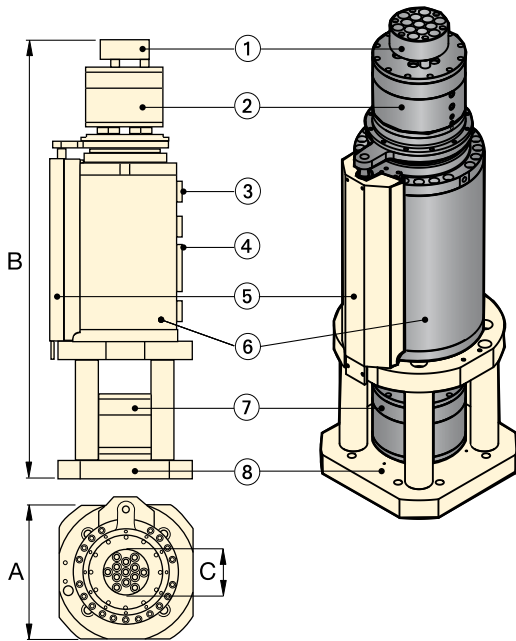

- ① Pre-Stress Cap
- ② Moving Lock Device
- ③ Pilot-Operated Check Valve
- ④ Electrical Connections
- ⑤ Stroke Sensor
- Anti Rotation Device
- ⑥ Lifting Cylinder
- ⑦ Static Lock Device
- ⑧ Chair

## TT Series



Rated Capacity per Jack:

**37 - 673 ton**

Effective Stroke:

**500 mm**

Working Pressure:

**300 bar**

### Strand Jacking Lifting Sequence

The sequence of operation is illustrated with the lock devices shown in *red* when the wedges are closed. The lock devices are shown in *blue* when the wedges are open.

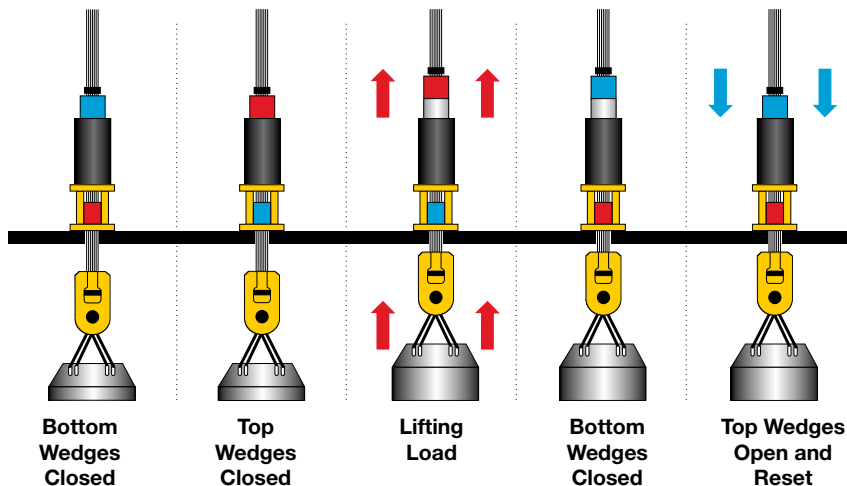

### PLC-Control Unit and Strand Jack Pumps

Using a network cable to interconnect each strand jack pump to the master control enables the use of an unlimited number of jacks.

Page: 231



### Mono Strand Lifting Jack

For heavy-lifting applications where a crane or hoist will not fit, the **ST-120M06** may be the only solution. Contact Enerpac for more details on this unique lifting solution.

### SELECTION CHART

Strand Jack Capacity <sup>1)</sup>	Model Number Strand Jack	Strand Diameter <sup>2)</sup>	Number of Strands	Effective Stroke	Effective Area	Nominal Working Pressure	Dimensions (mm)		
							A	B (extended)	C
ton (kN)		inch (mm)		(mm)	(cm <sup>2</sup> )	(bar)			
37 (360)	TT-36SJ306	0.60 (15,2)	3	500	123	300	300	2270	60
86 (840)	TT-84SJ706	0.60 (15,2)	7	500	287	300	430	2290	93
147 (1440)	TT-144SJ1206	0.60 (15,2)	12	500	466	300	490	2298	133
232 (2280)	TT-228SJ1906	0.60 (15,2)	19	500	754	300	600	2330	169
330 (3240)	TT-324SJ2706	0.60 (15,2)	27	500	1089	300	650	2330	208
453 (4440)	TT-444SJ3706	0.60 (15,2)	37	500	1486	300	700	2652	246
587 (5760)	TT-576SJ4806	0.60 (15,2)	48	500	1865	300	760	2693	284
673 (6600)	TT-660SJ5506	0.60 (15,2)	55	500	2199	300	900	2775	291

<sup>1)</sup> When used with compacted heavy lifting strand. Additional capacities and strokes are available.

<sup>2)</sup> Strand jacks are also available for 18,0 mm (0.70 inch) strand. Contact Enerpac for further information.



▼ Shown: TTP-Series, Strand Jack Hydraulic Pump



- Multiple pump and reservoir options
- PLC-controlled operation
- Steel frame and lifting eyes
- One pump per strand jack allows for short connections and flexible jack positions
- Pumps can be interconnected with a network cable.

**Premium Options:**

- Variable frequency drive for flow control and accurate synchronization between multiple lifting points
- One pump to operate multiple jacks
- Fully enclosed cabinet
- Oil cooler for operation in high temperature environments or continuous operation
- Reinforced cabinet with steel frame and lifting lugs
- Oil pre-heater in low temperature applications
- Biodegradable oil.

## Hydraulic Power for Demanding Strand Jacking Applications

Motor Size:

**5,5 - 37 kW**

Lifting Speed:

**1 - 29 m/hr**

Working Pressure:

**300 bar**



**Hand Pendant**

Allows individual control of strand jacks for set-up and manual operation. Included with each pump unit.



**Contact Enerpac!**

Contact the Enerpac office nearest to you for advice and technical assistance in the layout of your ideal Lifting System:  
**integratedsolutions@enerpac.com.**  
or visit: **www.enerpac.com.**



**TT-Series Strand Jacks**

Multi Strand Jacks for accurate lifting, lowering or horizontal movements of heavy loads.

Page: **228**



▼ Two concrete arches of this viaduct in Silleda, Spain are rotated and lowered by Enerpac Heavy Lifting Strand Jacking Systems.



▼ Shown: Master PLC-Control Unit



- Modular based system
- Control up to 32 strand jacks with one master controller
- Multiple controllers can be networked
- Individual or synchronous control
- Individual and accumulative stroke and load display
- Stroke and load alarms for safety
- Data logging capabilities.

▼ Strand jack pumps and eight strand jacks are networked to the master PLC-controller to lift twelve ball mills, weighing 1500 ton each, at a mining facility in Australia. By using a network cable to interconnect each strand jack pump, multiple strand jacks can be operated from one master controller.



## Control Multiple Strand Jacks from One Master Controller

▼ Bridge launching with Enerpac Heavy Lifting Strand Jacks.



▼ Bridge launching with Enerpac Heavy Lifting Strand Jacks.





▼ Shown: BLS-506 in three lifting positions.



- Double-acting cylinder with solid plunger design
- Simple three-stage operation
- Swivel saddle and large support attachments for stability
- Anti-rotation device
- Built-in overload protection.
- Option: stroke sensors for use with Enerpac synchronous lifting systems
- Capacity per lifting point 50 - 200 ton. Other capacities and strokes available, please contact Enerpac.

▼ PLC-controlled hydraulic movement: Enerpac stage lift systems lift and lower the umbrella deck on the world's largest concrete block builder with 1,0 mm accuracy, provided by 30 hydraulic climbing units in an integrated hydraulic system. Each climbing unit consists of two 70 ton double-acting cylinders and two 20 ton locking cylinders.



## A Simple Solution to Incremental Lifting



### Lifting Height

Stage-lift cylinders overcome the usual limitation of lift height imposed by the cylinder's plunger stroke length. Large objects, such as oil tanks, can be lifted, held and lowered for maintenance without sending for a crane.



### Synchronous Lift System

Multi-cylinder arrangements can be powered and fully synchronized by Enerpac's Synchronous Lift System.

Page: **224**

▼ Typical stage-lift application using a custom built Enerpac system to lift the 360 ton Akkerwinde wooden bridge in the Netherlands.



# Double-Acting Stage-Lift Cylinders



## Stage Lifting Application

For many lifting applications, the cylinder stroke can not be made long enough to lift the load to the required height. There is a direct relationship between the stroke length and the collapsed height of a cylinder. This relationship many times prevents a cylinder with the proper stroke length from also fitting in the required position to lift the load correctly. When these limitations are experienced, sometimes Stage-Lifting is the only solution.

Stage-Lifting is the process of lifting the load to the maximum stroke of

the cylinder and then “cribbing” or holding, the load at this point. Once this is done and the load is secure, the cylinder is retracted, cribbing is then placed under the cylinder and then the cycle is repeated. This stage-lifting cycle allows the load to be lifted many times the stroke of the cylinder and total height is only limited by the strength and stability of the cribbing system.

The BLS-Series of cylinders feature attachments that facilitate the cribbing application, by providing reaction points for both the load and the piston cribbing reaction points.

## BLS Series



Capacity per Lifting Point:

**50 - 200 ton**

Stroke per Stage:

**150 mm**

Maximum Operating Pressure:

**700 bar**

### ▼ Stage Lifting Sequence

- Step 1:** The Stage Lift cylinder is placed on a solid support under the load (retracted plunger).
- Step 2:** Plunger extends, lifting the load and giving clearance to insert two outer blocks under the spreading plate.

- Step 3:** Plunger retracts, giving clearance to position the central blocks which will support the plunger plate for the next extension.
- Step 4:** Plunger extends, lifting the load, giving clearance to insert two new blocks, placed crosswise under the spreading plate.

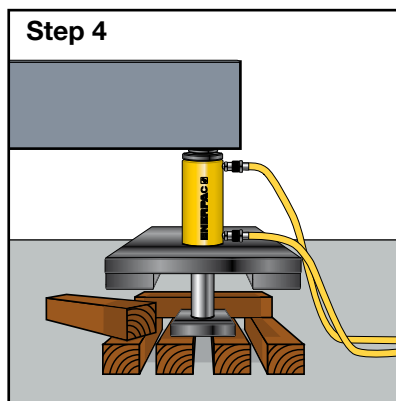
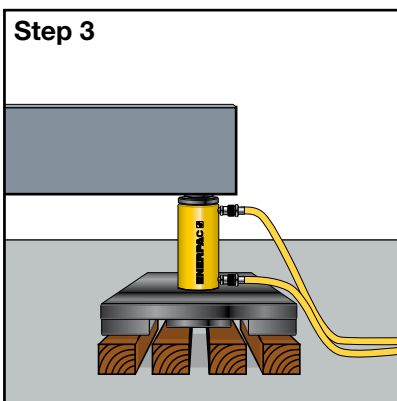
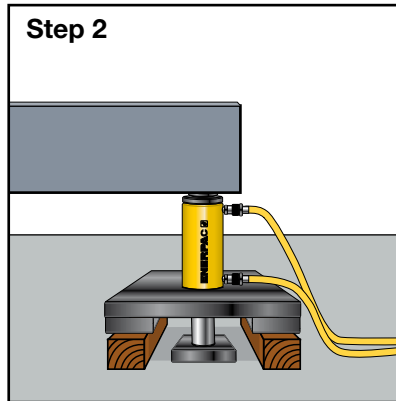
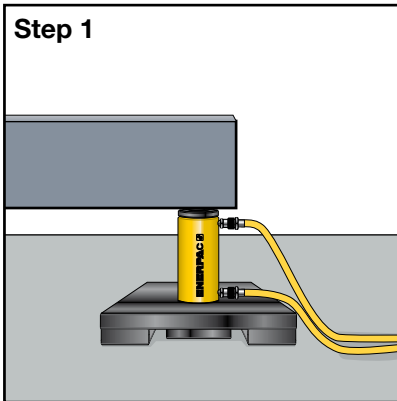

### Think Safety

Manufacturer's rating of load and stroke are maximum safe limits.

Good practice encourages using only 80% of these ratings!



### Lifting an Unbalanced Load?

See our “Yellow Pages” for multi-cylinder set-ups

Page: 245

- ▼ Bridge maintenance with synchronous stage lifting systems. Two systems are networked to a PLC-controlled 8-point lift and crib system.





▼ SHS-Series 4-Point SyncHoist System



- High precision load manoeuvring, vertically and horizontally – using one crane
- Reduces the risk of damage from oscillations of wire rope due to sudden crane starts/stops
- Vastly improving operating speed and worker safety
- Weather conditions play less critical role
- Intelligent hydraulics turn lifting into high accuracy hoisting and load positioning system
- High accuracy (+/- 1,0 mm)
- 700 bar double-acting push/pull cylinders with parachute valves for added safety in case of hose rupture or coupler damage
- Cost reduction when compared to conventional load positioning methods.

**Options for system management & control:**

- Manual control: stroke control and system warning functions
- Extended manual control: stroke control, load and stroke display and system warning functions
- PLC-control: fully monitorized system with programmable functions using touch screen and wireless remote control and system warning functions
- Contact Enerpac for stroke, capacity or control options.

## Accurate Hoisting and Load Positioning Enhancing a Crane's Capability



### Typical SyncHoist Functions and Applications

**Functions**

- High precision load positioning
- Pre-programmed positioning, tilting and aligning
- Counterweighing – determining centre of gravity.

**Applications**

- Positioning of roof sections, concrete elements, steel structures
- Positioning of turbines, transformers, fuel rods
- Precise machinery loading, mill rod changes, bearing changes
- Precise positioning of pipe lines, blow out valves
- Positioning and aligning of ship segments prior to assembly.

Visit [www.enerpac.com](http://www.enerpac.com) to learn more about SyncHoist and download the animation.

▼ Bridge segments are hoisted from the ground, being positioned with a 4-point SyncHoist system with fully monitorized cylinders.



# SyncHoist - High Precision Load Positioning

## SHS-Series, Enerpac SyncHoist Systems

System Load Capacity	240 ton (2350 kN)	320 ton (3125 kN)	440 ton (4310 kN)
Max. handling load <sup>1)</sup>	4x60 ton	4x80 ton	4x110 ton
Number of lifting points <sup>2)</sup>	4	4	4
System reach	1500 mm	1500 mm	1500 mm
<b>Cylinder configuration</b>			
Push force @ 90 bar	10,5 ton	14,0 ton	22,0 ton
Pull force @ 700 bar	60,0 ton	80,0 ton	110,0 ton
Plunger stroke <sup>2)</sup>	1500 mm	1500 mm	1500 mm
<b>Pump single-stage</b>			
Oil flow at 700 bar	4,0 l/min	4,0 l/min	4,0 l/min

### Control options & system management <sup>3)</sup>

Manual control	Manual directional control valves
Extended manual control	Joystick controls with position display
PLC-control <sup>4)</sup>	Fully closed-loop control system

- <sup>1)</sup> Subject to angle and position of lifting cylinders.  
<sup>2)</sup> Each cylinder equipped with parachute valve for added safety in event of hose/coupler damage.  
 Note: Enerpac SyncHoist have standard 4 lifting points. In the event that more or less lifting points are required, contact your local Enerpac representative.  
<sup>3)</sup> See chart below for detailed control features.  
<sup>4)</sup> Required for counterweighing (centre of gravity).

## SHS Series



Capacity Per Lifting Point:

**60 - 110 ton**

Maximum Stroke:

**1500 mm**

Accuracy Over Full Stroke:

**± 1,0 mm**

Maximum Operating Pressure:

**700 bar**



▲ *Perfectly synchronised balance: Naval ship superstructure weighing over 600 tons placed on the hull using Enerpac's hydraulic SyncHoist.*

▼ *Designs of Santiago Calatrava (architect) often require creative technological solutions. Enerpac SyncHoist System is one of them and was used for roof positioning of the Palace of the Arts in Valencia (Spain). Segments are hoisted from the ground, being positioned with four fully monitored cylinders.*



### Three options for system management and control

Contact Enerpac for the following options, or other customised stroke, capacity and control configurations.

#### 1. Manual control

- Plunger stroke control
- System warnings for:
  - oil level, filter indication, thermal motor protection.

#### 2. Extended manual control

- Plunger stroke control
- Load & stroke display
- System warnings for:
  - maximum cylinder load control setting
  - oil level, filter indication, thermal motor protection.

#### 3. PLC-control

- Touch screen
- Remote wireless radio control
- Load and stroke monitoring
- Load calculations (centre of gravity)
- Pre-programmable motions and data recording
- System warnings for:
  - maximum cylinder load control setting
  - stroke and position control
  - oil level, filter indication, thermal motor protection.

▼ Shown: Uni-Lift® Mechanical Actuators



## Precision Positioning and Control in a Mechanical Package

- Machine screw versions up to 250 ton for low-cycle, high-load applications and positive load holding
- Ball-Screw versions up to 5 tons for high-cycle, high-speed applications
- Electro-Mechanical Drive System can be interlinked and easily synchronized
- Precision rolled load screws Class 3 fit for additional strength
- Preloaded tapered roller bearings tolerate high thrust loads and minimize side loading
- Precision machine gear sets provide minimum backlash while reducing wear
- Wide variety of base-mounting and screw-end configurations.



### Maximize Your System Control

Custom control boxes designed to meet your specific application requirements.



### System Accessories

Enerpac offers a large array of motors, drive components, and boots to meet any demanding project.



◀ *Uni-Lift® Actuators were the ideal choice to position and adjust the complex scaffolding for aircraft maintenance. Precision movement and flexibility was an asset in getting the job done efficiently and safely.*



# Uni-Lift® Mechanical Actuators



Ball Screw Cutaway



Machine Screw Cutaway

## B, M Series



Capacity:

**2,2 - 2222 kN**

Maximum Stroke:

**380 - 6095 mm**

Actuator Types:

**Machine & Ball Screw**

### Design Features:

- Available with translating, rotating and keyed load screw designs
- High-strength rolled load screws provide maximum durability
- Rugged aluminum alloy and ductile iron housings for demanding or rigorous environment
- Corrosion resistant zinc plating is standard on most units
- The widest range options gear ratios are available to meet all application requirements
- Speeds up to 0,17 m/sec.

### Actuator Accessories:

- High-quality bellow boots for added loadscrew protection
- Easy mounting of optional screw ends are available in plain, top plate and clevis design
- Wide selection of motors and C-face adaptors
- Limit switches and encoders for complete system control
- Couplers and shafting available for individual system requirements
- A large choice of mitre gear boxes and reducers provide maximum system design flexibility
- Custom built control boxes to meet your specific need.



### Over-travel Stop Nuts

Provide a mechanical stop and are used to prevent the ejection of the power screw from the actuator.



### CAD Modeling Software

Our experienced sales team and application engineers will deliver the precise support you need to meet the most demanding and unique requirements. State-of-the-art CAD modeling software offers the needed flexibility to design custom built "special" screw jacks to suit all customer needs. See Uni-Lift® Solutions in Action.

Page: 238

### Typical Mechanical Actuator Set-Up

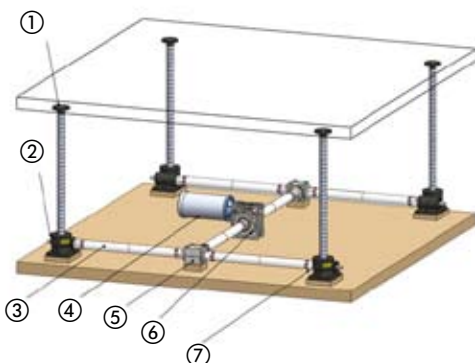

- ① Top Plate (4x)
- ② Uni-Lift® Mechanical Actuator (4x)
- ③ Shafting (6x)
- ④ Electric Motor (1x)
- ⑤ Mitre Gearbox (2x)
- ⑥ Reducer (1x)
- ⑦ Coupler (1x)



### Contact Enerpac!

Contact the Enerpac office nearest to you for advice and technical assistance in the layout of your ideal Lifting System or visit us at: [www.enerpac.com](http://www.enerpac.com). Or ask Enerpac for assistance by email: [integratedsolutions@enerpac.com](mailto:integratedsolutions@enerpac.com).



## Precision Positioning and Control in a Mechanical Package.

### Actuators move the ramp of ferry dock ►

Engineers utilized two (2) Uni-Lift® 100-ton actuators with 5 metres of travel to raise and lower the ramp on each ferry dock along the Mississippi River, USA. The Department of Transportation engineers needed a way of lifting and lowering ramps during high and low tide conditions, while holding up to the harsh environmental conditions of the gulf coast.



### ◀ Opening large doors of plating tanks

When engineers needed a quick and compact way of opening the large doors of these large plating tanks, they contacted Uni-Lift® for help. This application utilizes two 5-ton double-clevis actuators, with a motor and a limit switch box mounted on each actuator. The operator just pushes a button to open the doors, and pushes another button to close them. This method greatly enhances operator safety and helps to prevent cross contamination between tanks.

### OEM motion control solutions ►

Uni-Lift® screw jacks are used extensively in a variety of material handling applications. Whether used in positioning conveyer belts, placing tension on overhead beams or moving heavy-duty equipment, Uni-Lift® actuators are the ideal solution for many jackings, tensionings, and positioning applications. Whether you have one lifting point or multiple lifting points, Uni-Lift® actuators are the perfect solution for many different OEM motion control applications.





## Enerpac 'Yellow Pages' stand for Hydraulic Information!

If selecting hydraulic equipment is not your daily routine, then you will appreciate these pages. The 'Yellow Pages' are designed to help you work with hydraulics. They will help you to better understand the basics of hydraulics, of system set-ups and of the most commonly used hydraulic techniques. The better your choice of equipment, the better you will appreciate hydraulics. Take the time to go through these 'Yellow Pages' and you will benefit even more from Enerpac High Pressure Hydraulics.

Section		Page
Safety Instructions		240-241 ▶
Pump Selection		242 ▶
Selection Worksheet		243 ▶
Basic System Set-ups		244-245 ▶
Basic Hydraulics		246-247 ▶
Conversion Tables		248 ▶
Cylinder Speed Charts		249 ▶
Valve Information		250 ▶
Global Warranty Policy		251 ▶
Torque Tightening		252-253 ▶
Hexagon Bolt and Nut Sizes		254 ▶



[www.enerpac.com](http://www.enerpac.com)

Visit our web site for the complete Global Lifetime Warranty or call your Authorized Service Center.

Page: 251

### GLOBAL LIFETIME WARRANTY STATEMENT

Enerpac products are warranted to be free of defects in materials and workmanship. Any product that does not conform to specification will be repaired or replaced at Enerpac's expense, anywhere in the world; simple as that!

This warranty does not cover ordinary wear and tear, abuse, misuse, alterations, or the use of improper fluids. Determination of the authenticity of a warranty claim will be made only by Enerpac or its Authorized Service Centers (see page 251).

Enerpac is certified for several quality standards. These standards require compliance with standards for management, administration, product development and manufacturing.



#### ATEX 95 Certified

The ZA and XA-Series air pumps are tested and certified according to the Equipment Directive 94 / 9 / EC "ATEX Directive".

#### Product Design Criteria

All hydraulic components are designed and tested to be safe for use at maximum 700 bar (10.000 psi) pressure unless otherwise specifically noted.

#### DIN 20024

Enerpac thermoplastic hoses are related to the criteria set forth in Deutsche Industrie Norm 20024.



Where specified, Enerpac electric power units meet the design, assembly and test requirements of the Standards Council of Canada (CAN C22.2 No. 68-92), and UL73 for the United States. Units were tested and certified for both USA and Canada by TUV, a nationally recognized testing laboratory.

#### EMC Directive 2004/108/EC

Where specified, Enerpac electric power pumps meet the requirements for Electro-magnetic Compatibility per EMC Directive 2004/108/EC.



Enerpac provides a Declaration of Conformity and CE marking for products that conform with the European Community Directives.

#### ASME B30.1

Our cylinders fully comply with the criteria set forth by the American National Standards Institute (except 'BRD', 'CLL' and CLS series).



Enerpac worked hard to earn the quality rating ISO 9001, in its ongoing pursuit of excellence.



# Safety Instructions



When used correctly, hydraulic power is one of the safest methods of applying force to your work. And to that end we offer

some DO's and DON'Ts, simple common sense points which apply to practically all Enerpac hydraulic products.

- Lift slowly and check often
- Avoid standing in the line of force
- Anticipate possible problems and take steps to avoid them.

The line drawings and application photo's of Enerpac products throughout this catalog are used to portray how some of our customers have used hydraulics in industry.

In designing similar systems, care must be taken to select the proper components that provide safe operation and fit your needs. Check to see if all safety measures have been taken to avoid the risk of injury and property damage from your application or system.

Enerpac can not be held responsible for damage or injury, caused by unsafe use,

maintenance or application of its products. Please contact the Enerpac office or a representative for guidance when you are in doubt as to the proper safety precautions to be taken in designing and setting up your particular system.

In addition to these tips, every Enerpac product comes with instructions spelling out specific safety information. Please read them carefully.

## Jacks

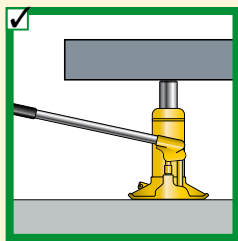
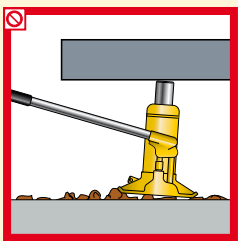

Provide a level and solid support for the entire jack base area.

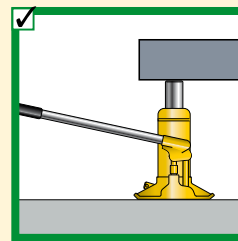
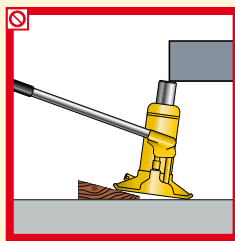

The entire jack saddle must be in contact with the load. Movement of the load to be in the same direction as jack plunger.



Never place any part of your body under the load. Ensure the load is on a solid support before venturing under.

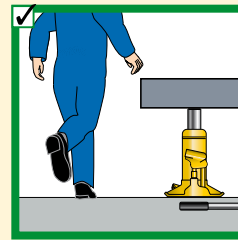
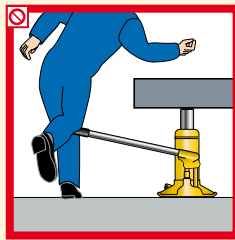

Remove the jack handle when it is not being used.

## Cylinders

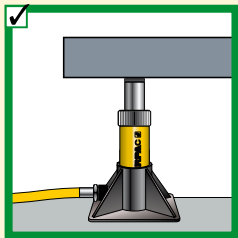
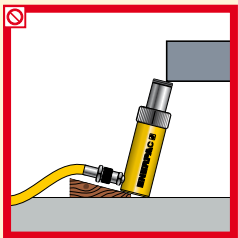

Provide a solid support for the entire cylinder base area. Use cylinder base attachment for more stability.

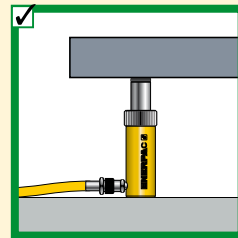
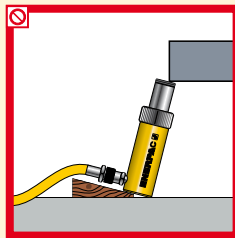

The entire cylinder saddle must be in contact with the load. Movement of the cylinder must be parallel with the movement of the load.

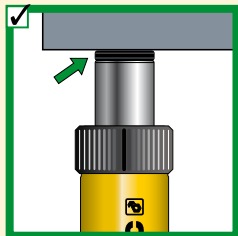
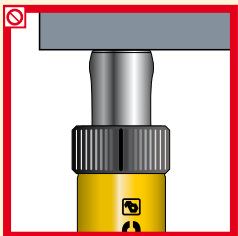

Do not use cylinder without saddle. This will cause plunger to "mushroom". Saddles distribute load evenly on the plunger.

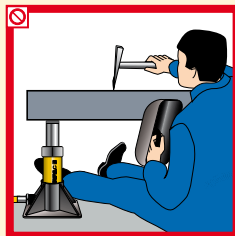

As with jacks, never place any part of your body under the load. Load must be on cribbing before venturing under.



Always protect cylinder threads for use with attachments.

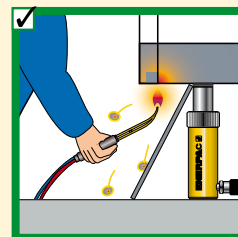

Keep hydraulic equipment away from open fire and temperatures above 65 °C (150 °F).





## General

**80%** Manufacturer's rating of load and stroke are maximum safe limits. **80%** Good practice encourages using only 80% of these ratings!

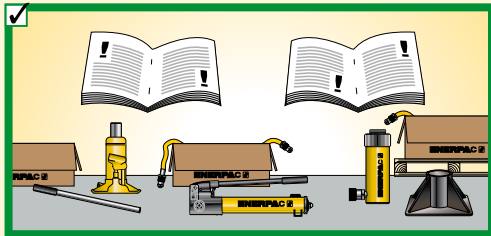

Always read instructions and safety warnings that come with your Enerpac hydraulic equipment.

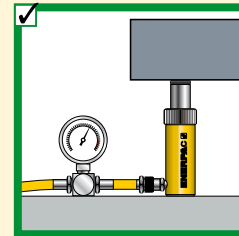
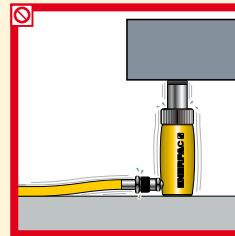

Don't override the factory setting of relief valves. Always use a gauge to check system pressure.

## Pumps

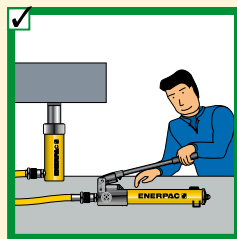
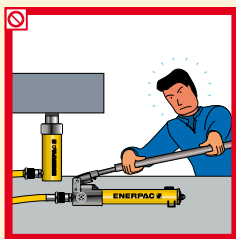

Don't use handle extenders. Hand pumps should be easy to operate when used correctly.

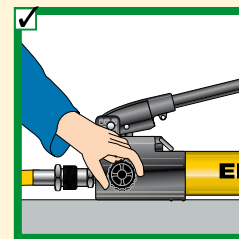
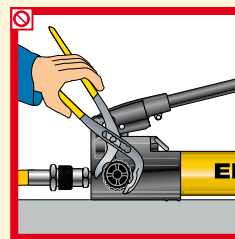

Close release valve finger tight. Using force will ruin the valve.

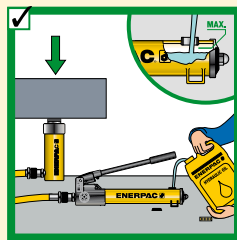
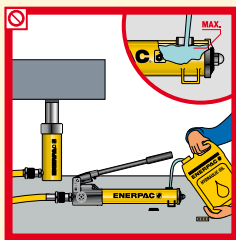

Fill pump only to recommended level. Fill only when connected cylinder is fully retracted.

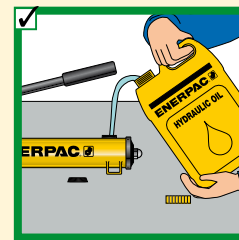
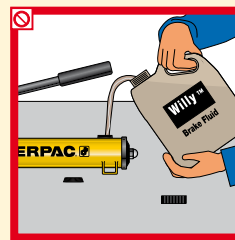

Use only genuine Enerpac hydraulic oil. Wrong fluid can destroy seals and pump and will render your warranty null and void your guarantee.

## Hoses and couplers

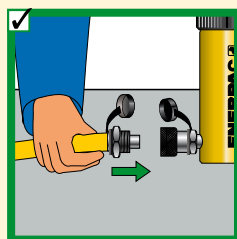
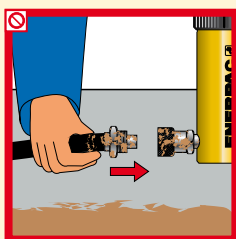

Clean both coupler parts before connecting. Use dust caps when coupler parts are not connected.

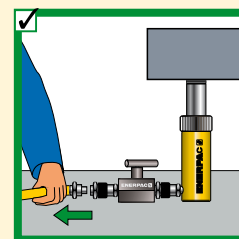
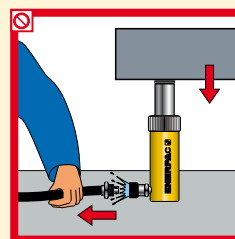

Detach cylinder only when fully retracted or use shut-off valves or safety valves to lock-in cylinder pressure.

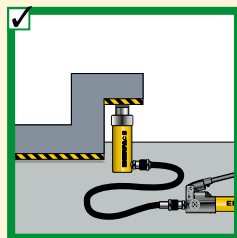
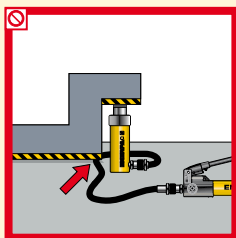

Keep hoses away from the area beneath loads.

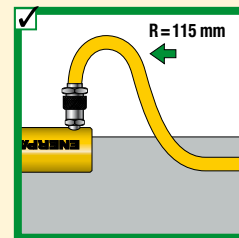
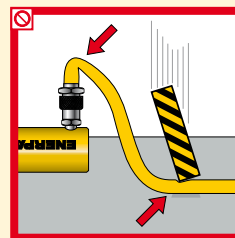

Don't kink hoses. Bending radius should be at least 115 millimetres. Don't drive over or drop heavy objects on hoses.

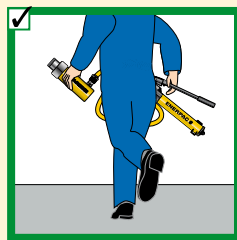
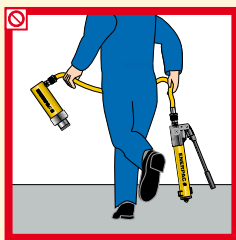

Don't lift hydraulic equipment by the hoses.

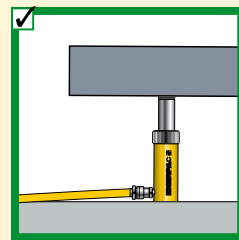
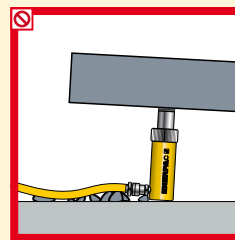





Never allow the cylinder to be lifted off of the ground through the couplers.











# Pump Selection

## ▼ HAND PUMP AND SINGLE-ACTING CYLINDER MATCHING CHART

Capacity (ton) ▶ ▼ Stroke	5 t	10 t	15 t	25 t	30 t	50 t	60 t	75 t	100 t	150 t
< 25 mm										
25 mm										
50 mm										
75 mm										
100 mm										
125 mm										
150 mm										
175 mm										
200 mm										
225 mm										
250 mm										
300 mm										
325 mm										
350 mm										
		<b>P-392</b>				<b>P-80</b>			<b>P-462</b>	
		Page: 66			Page: 68			Page: 68		

Note: Selection based on oil capacity requirements of cylinders.

## ▼ POWER PUMP SELECTION CHART

Oil Flow*	Low (0,1 - 0,3 l/min)		Medium (0,5 - 2,0 l/min)		High (2,0 - 14,5 l/min)	
Usable Oil Capacity	1,9 - 3,8 litres	5,7 litres	4 - 40 litres	4 - 40 litres	10 - 40 litres	60 litres
Duty Cycle**	Intermittent	Extended	Intermittent	Extended	Extended	Extended
Portable/Stationary***	Portable	Stationary	Portable	Stationary	Stationary	Stationary
Recommended Series	<b>PU-Series Economy</b>	<b>PE-Series Submerged</b>	<b>ZU4-Series</b>	<b>ZE3-, ZE4- and ZE5-Series</b>	<b>ZE6-Series</b>	<b>PP 8000-Series PP 9000-Series</b>
						
	Page: 78	Page: 80	Page: 86	Page: 92	Page: 92	Page: 98

\* Oil Flow

- Determined by motor size
- Directly affects electrical power requirements
- Determines cylinder or tool speed

\*\* Duty Cycle

- Extended applications require more than one hour of interrupted pump use
- Intermittent would be used less than one hour of continuous pump use.

\*\*\* Portability

- |                               |                                  |
|-------------------------------|----------------------------------|
| <u>Portable</u>               | <u>Stationary</u>                |
| • Ergonomic handles           | • Mounting options               |
| • Flexible power requirements | • Normally requires stable power |

# Selection Worksheet



▼ Complete the following information to select the right products:

Cylinder Selection	Question:	Tips/help	Data	Model Number
	<b>Total force required in tons:</b>	Total load		
	<b>Number of cylinders required:</b>	Number of lifting points		
	<b>Force per cylinder in ton:</b>	Should be 80% of total cylinder cap.		
	<b>Stroke required:</b>	Plunger travel		
	<b>Single or double-acting (D/A):</b>	D/A used when pull force is required, or retract speed is critical		
	<b>Type of plunger required:</b>	Hollow or solid		
	<b>Collapsed height required:</b>			
	<b>Optional saddle required:</b>	Tilt, Grooved, Flat		
	<b>Cylinder base:</b>	Improves stability		
	<b>Cylinder attachments: (RC-series)</b>	Expanded functions		
	<b>Selected cylinder model:</b>		▶	
	<b>Including coupler model:</b>			

Pump Selection	Available power source:	<input type="checkbox"/> Manual <input type="checkbox"/> Battery <input type="checkbox"/> Electric <input type="checkbox"/> Compressed Air <input type="checkbox"/> Petrol		
The three most commonly selected pumps are hand pumps, electric pumps and air-driven pumps. Gas powered pumps, however can be selected in the same way.	<b>Hand pump</b>	Not for high cycle applications		
	<b>Single- or double-acting operation</b>	Use 4-way valve for D/A applications		
	<b>Selected hand pump:</b>		▶	
	<b>Electric or Compressed Air pump</b>			
	<b>Need for portability:</b>			
	<b>Duty cycle:</b>	Intermittent or extended		
	<b>Required usable oil capacity:</b>	Intermittent = 1,2 x oil capacity high cycle = 2 x oil capacity		
	<b>Available Voltage:</b>			
	<b>Lifting speed (Important/not important):</b>	Use speed chart on page 249		
	<b>Type of control:</b>	Manual/remote pendant		
<b>Type of actuation/function:</b>	Advance/hold/retract			
<b>Accessories:</b>	Filter Kit, Level Switch, Roll bar ...			
<b>Selected pump:</b>		▶		
<b>Including Coupler:</b>	Oil connection			

System Components	Number of hoses and length required:		
	<b>Selected Hoses:</b>		▶
	<b>Manifold or tee:</b>		▶
	<b>Extra hose per manifold (2):</b>		▶
	<b>Gauge (kN or bar scale):</b>	GF-series for high cycle	▶
	<b>Gauge adapter:</b>		▶
	<b>Fittings:</b>		▶
	<b>Pressure Relief Safety Valve:</b>		▶
	<b>Load-holding Valve(s):</b>		▶
	<b>Hydraulic oil:</b>		▶



# Basic System Set-ups

**1 Cylinder**

Applies hydraulic force.  
Page 5

**2 Cylinder Base Plate**

For applications like lifting where additional cylinder stability is required.  
Page 10

**3 Pump**

Provides hydraulic flow.  
Page 65

**4 Hose**

Transports hydraulic fluid.  
Page 120-121

**5 Male Coupler**

For quick connection of the hose to system components.  
Page 122-123

**6 Female Coupler**

For quick connection of the hose end to the system components.  
Page 122-123

**7 Gauge**

To monitor pressure of the hydraulic circuit.  
Page 126-131

**8 Gauge Adaptor**

For quick and easy gauge installation.  
Page 132

**9 Swivel Connector**

Allows proper alignment of valves and/or gauges. Used when units being connected cannot be rotated.  
Page 132

**10 Auto-Damper Valve V-10**

Used to protect gauge from damage due to sudden pressure pulses in the system. Needs no adjustment and allows correct positioning of gauge, prior to tightening.  
Page 134-135

**11 4-Way Directional Control Valve**

Controls the direction of hydraulic fluid in a double-acting system.  
Page 114-115

**Single-acting push application**, such as in a press.

The hand pump offers controlled cylinder advance, but may require many hand pump strokes in longer stroke applications when the cylinder capacity is 25 ton or above.

Examples of pump, hose and cylinder sets can be found on page 62.

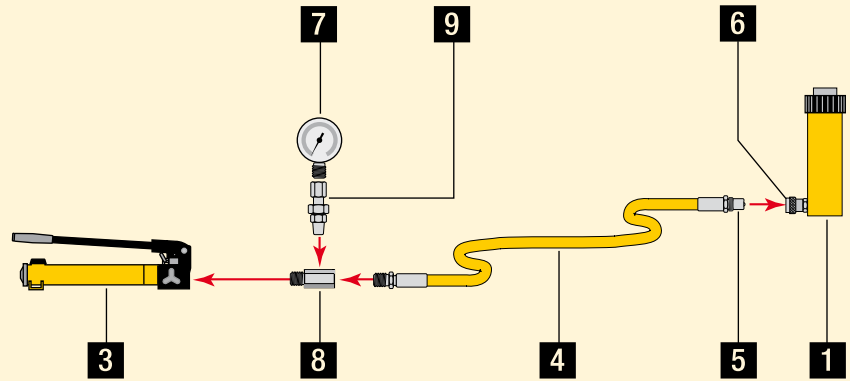

Single-acting cylinder with longer stroke used for lifting applications.

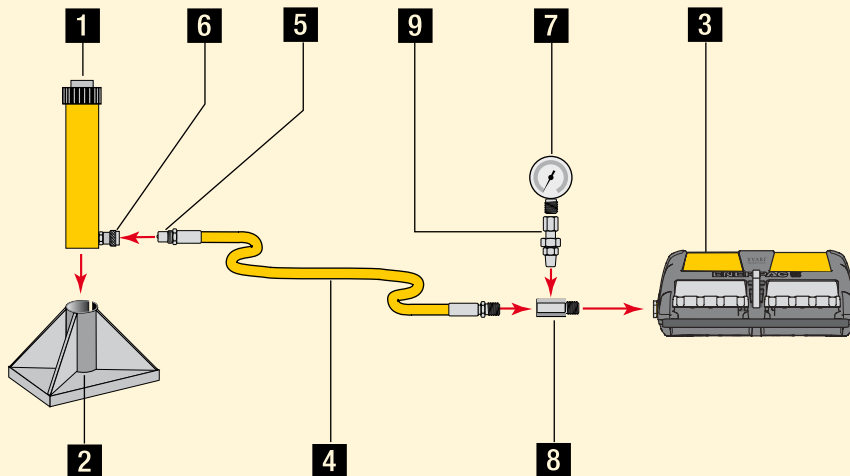

Double-acting cylinder set-up used for lifting applications where a slow controlled descent of the load must be maintained.

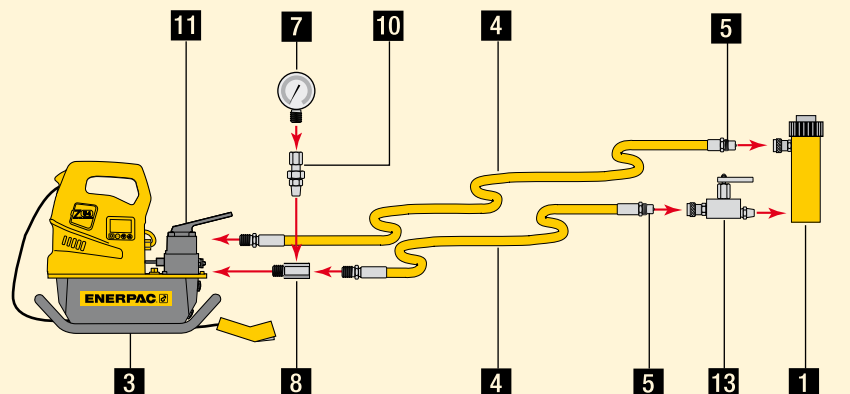



**Double-acting cylinder set-up** used in a push/pull application.

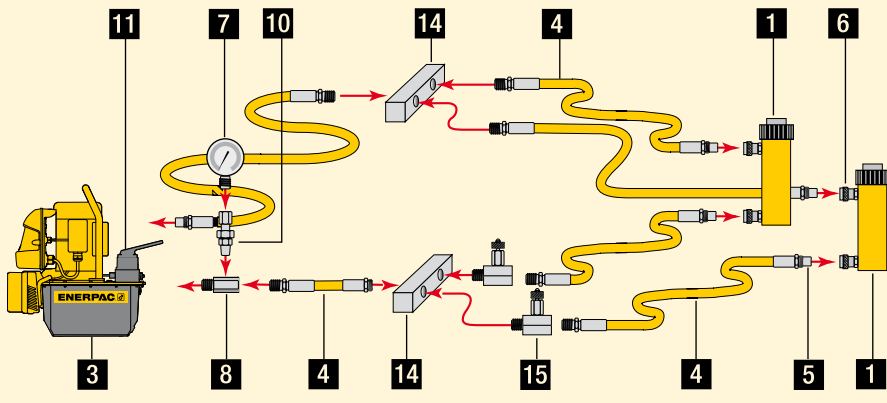

**12 3-Way Directional Control Valve**  
Controls the direction of hydraulic fluid in a single-acting system.  
Page 114-115

**13 Safety Holding Valve**  
Controls load descent in lifting applications.  
Page 134-135

**14 Manifold**  
Allows distribution of hydraulic fluid from one power source to several cylinders  
Page 124

**15 Needle valve**  
Regulates the flow of hydraulic fluid to or from the cylinders.  
Page 134-135

**Two point lifting set-up** using single-acting cylinders.

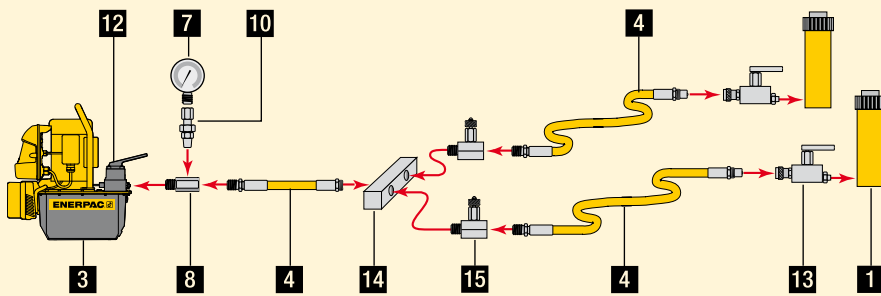

**Four point lifting set-up**, using single-acting cylinders and directional control valves.

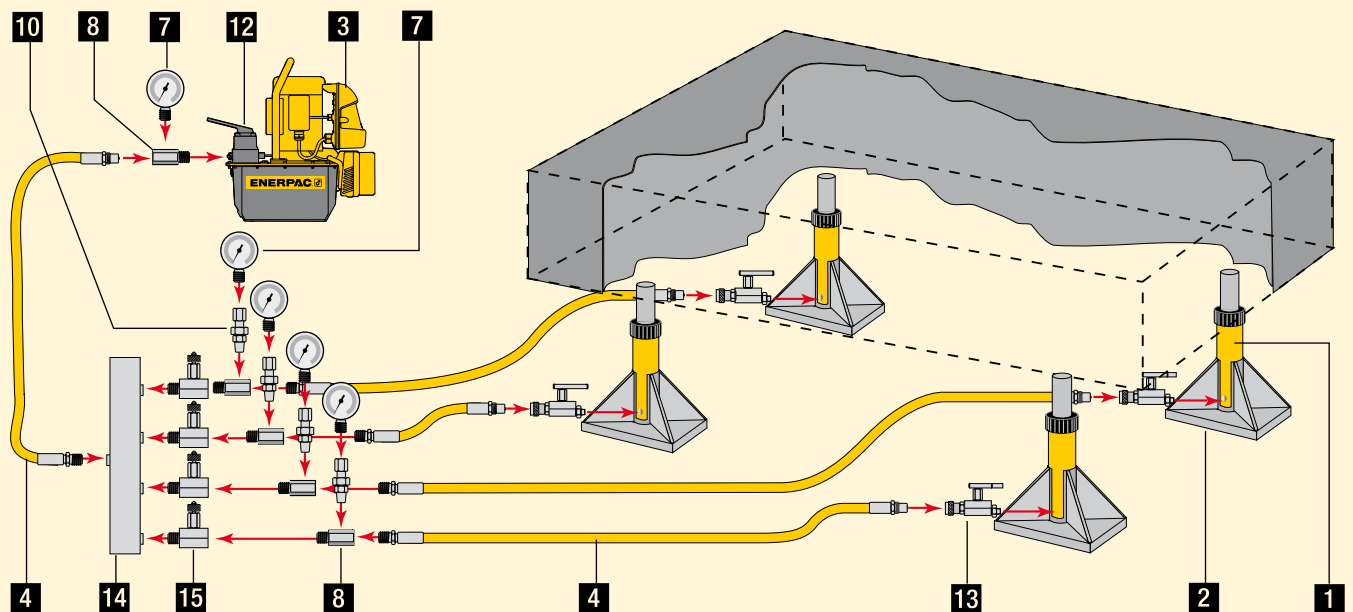

**www.enerpac.com**  
Visit our web site to learn more about hydraulics and system set-ups.





**Flow** A hydraulic pump produces flow.

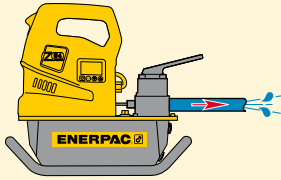

**Pressure** Pressure occurs when there is resistance to flow.

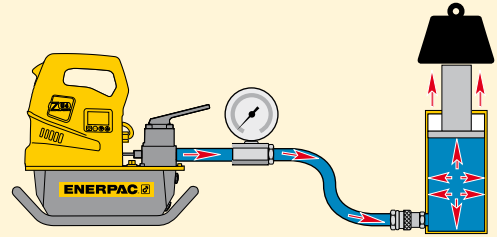

## Pascal's Law

Pressure applied at any point upon a confined liquid is transmitted undiminished in all directions (Fig. 1). This means that when more than one hydraulic cylinder is being used, each cylinder will lift at its own rate, depending on the force required to move the load at that point (Fig. 2).

Cylinders with the lightest load will move first, and cylinders with the heaviest load will move last (Load A), as long as the cylinders have the same capacity.

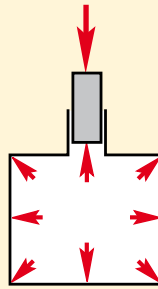
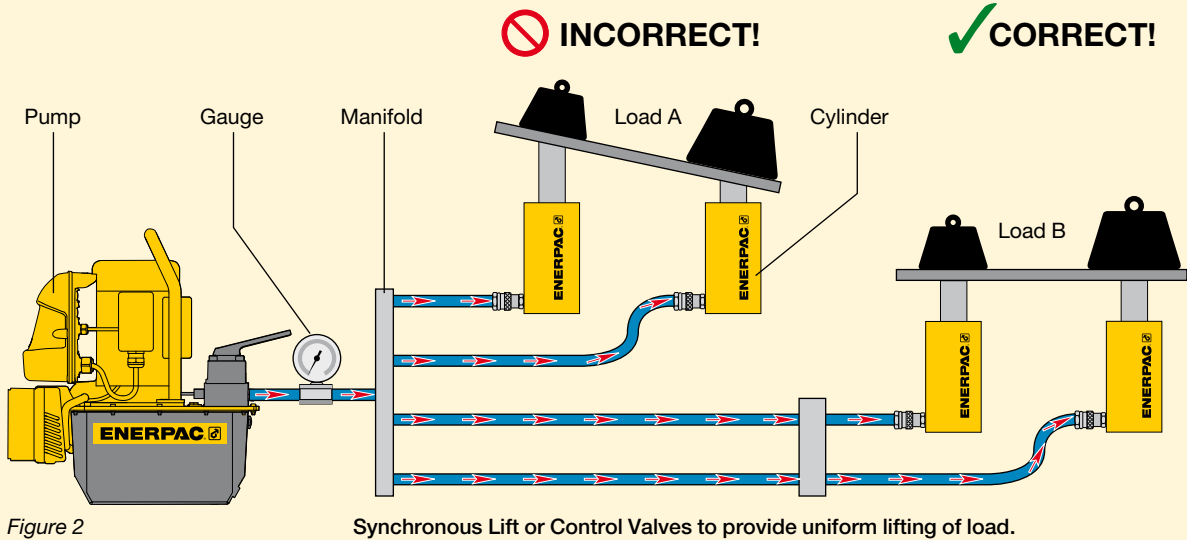

Figure 1

To have all cylinders operate uniformly so that the load is being lifted at the same rate at each point, either control valves (see Valve section) or Synchronous Lift System components (see Cylinder section) must be added to the system (Load B).



**CAUTION!**  
When lifting or pressing,  
always use a gauge.

A gauge is your 'window' to the system. It lets you see what's going on. You will find the gauges in the System Components section.



Learn more about hydraulics

Visit [www.enerpac.com](http://www.enerpac.com) to learn more about hydraulics and system set-ups.



## Force

The amount of force a hydraulic cylinder can generate is equal to the hydraulic pressure times the “effective area” of the cylinder (see cylinder selection charts).

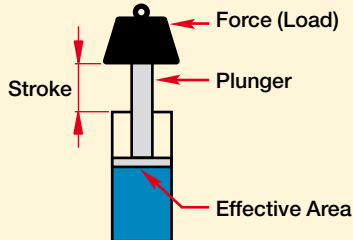

Force	=	Hydraulic Working Pressure	x	Cylinder Effective Area
F	=	P	x	A

Use this formula to determine either force, pressure or effective area if two of the variables are known.

## Example 1

An RC-106 cylinder with 14,5 cm<sup>2</sup> effective area operating at 700 bar will generate what force?

$$\text{Force} = 7000 \text{ N/cm}^2 \times 14,5 \text{ cm}^2 = 101500 \text{ N} = 101,5 \text{ kN}$$

## Example 2

An RC-106 cylinder lifting 7000 kg will require what pressure?

$$\text{Pressure} = 7000 \times 9,8 \text{ N} \div 14,5 \text{ cm}^2 = 4731,0 \text{ N/cm}^2 = 473 \text{ bar.}$$

## Example 3

An RC-256 cylinder is required to produce a force of 190.000 N. What pressure is required?

$$\text{Pressure} = 190.000 \text{ N} \div 33,2 \text{ cm}^2 = 5722,9 \text{ N/cm}^2 = 572 \text{ bar.}$$

## Example 4

Four RC-308 cylinders are required to produce a force of 800.000 N. What pressure is required?

$$\text{Pressure} = 800.000 \text{ N} \div (4 \times 42,1 \text{ cm}^2) = 4750,6 \text{ N/cm}^2 = 476 \text{ bar.}$$

Remember, since four cylinders are used together, the area for one cylinder must be multiplied by the number of cylinders used.

## Example 5

A CLL-2506 cylinder is going to be used with a power source that is capable of 500 bar. What is the theoretical force available from that cylinder?

$$\text{Force} = 5000 \text{ N/cm}^2 \times 366,4 \text{ cm}^2 = 1.832.000 \text{ N} = 1832 \text{ kN.}$$

## Cylinder Oil Capacity

The volume of oil required for a cylinder (cylinder oil capacity) is equal to the effective area of the cylinder times the stroke\*.

Cylinder Oil Capacity	=	Cylinder Effective Area	x	Cylinder Stroke
-----------------------	---	-------------------------	---	-----------------

\* Note: these are theoretical examples and do not take into account the compressibility of oil under high pressure.

## Example 1:

An RC-158 cylinder with 20,3 cm<sup>2</sup> effective area and 200 mm stroke requires what volume of oil?

$$\text{Oil Capacity} = 20,3 \text{ cm}^2 \times 20 \text{ cm} = 406 \text{ cm}^3$$

## Example 2:

An RC-5013 cylinder has an effective area of 71,2 cm<sup>2</sup> and a stroke of 320 mm. How much oil will be required?

$$\text{Oil Capacity} = 71,2 \text{ cm}^2 \times 32 \text{ cm} = 2278,4 \text{ cm}^3$$

## Example 3:

An RC-10010 cylinder has an effective area of 133,3 cm<sup>2</sup> and a stroke of 260 mm. How much oil will it require?

$$\text{Oil Capacity} = 133,3 \text{ cm}^2 \times 26 \text{ cm} = 3466 \text{ cm}^3$$

## Example 4:

Four RC-308 cylinders are being used, each with an effective area of 42,1 cm<sup>2</sup> and a stroke of 209 mm. How much oil will be required?

$$\text{Oil Capacity} = 42,1 \text{ cm}^2 \times 20,9 \text{ cm} = 880 \text{ cm}^3 \text{ for one cylinder}$$

Multiply by four to obtain the required capacity: 3520 cm<sup>3</sup>

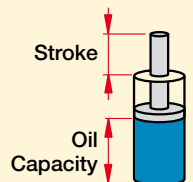

**CAUTION!**  
Enerpac oil will compress 2,28% at 350 bar and 4,1% at 700 bar.



# Conversion Tables

## Key to cylinder dimensions

Dimensions shown in the Selection Charts of the cylinder section are identified on the relevant drawings by the capital letter references listed here: A for collapsed height through Z1 for depth of internal base thread.

- A = Collapsed height
- B = Extended height
- C = Cylinder body length
- D = Cylinder outside diameter
- D1 = Cylinder width
- E = Cylinder inside diameter
- F = Plunger rod diameter
- G = Oil inlet thread
- H = Cylinder bottom to advance port
- I = Cylinder top to retract port
- J = Saddle outside diameter
- K = Cylinder rod protrusion at collapsed height
- L = Plunger centre to side of base
- M = Mounting holes to plunger centre
- N = Length of smaller cylinder part
- O = Plunger hole or thread of saddle
- P = Plunger thread length
- Q = Plunger outside thread
- U = Pitch (BC) of mounting holes
- V = Thread of cylinder mounting holes
- W = Collar thread
- X = Collar thread length
- Y = Centre hole diameter
- Z = Internal base thread
- Z1 = Depth of internal base thread

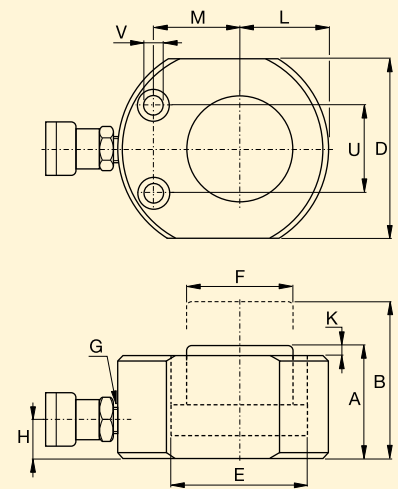
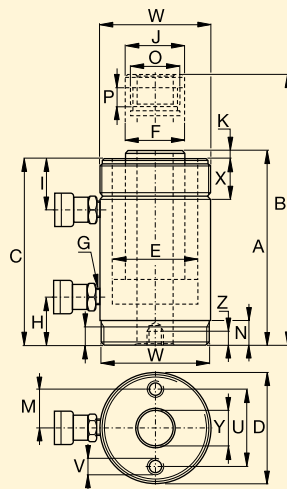

## Key to measurements

All capacities and measurements in the catalog are expressed in uniform values.

The conversion chart provides helpful information for their translation into equivalent systems.

All ton values specified in this catalogue are metric tonnes and are for cylinder class identification only. Please refer to the kN data for calculations.

**Free Conversion Calculator**  
Visit [enerpac.com](http://enerpac.com) and download the free conversion calculator.

### Pressure:

- 1 psi = 0,069 bar
- 1 bar = 14,50 psi
- = 9,8 N/cm<sup>2</sup>
- = 100.000 Pa
- 1 kPa = 0,145 psi
- 1 MPa = 145 psi

### Volume:

- 1 in<sup>3</sup> = 16,387 cm<sup>3</sup>
- 1 cm<sup>3</sup> = 0,061 in<sup>3</sup>
- 1 litre = 61,02 in<sup>3</sup>
- = 0,264 gal
- 1 USgal = 3785 cm<sup>3</sup>
- = 3,785 l
- = 231 in<sup>3</sup>

### Weight:

- 1 pound (lb) = 0,4536 kg
- 1 kg = 2,205 lbs
- 1 metric ton = 2205 lbs
- = 1000 kg
- 1 ton (short) = 2000 lbs
- = 907,18 kg

### Torque:

- 1 Nm = 0,738 Ft.lbs
- = 0,102 kgf.m
- 1 Ft.lbs = 1,356 Nm
- = 0,138 kgf.m

### Temperature:

- To Convert °C to °F:  
 $T^{\circ F} = (T_{\circ C} \times 1,8) + 32$
- To Convert °F to °C:  
 $T^{\circ C} = (T_{\circ F} - 32) \div 1,8$

### Other measurements:

- 1 in = 25,4 mm
- 1 mm = 0,039 in
- 1 in<sup>2</sup> = 6,452 cm<sup>2</sup>
- 1 cm<sup>2</sup> = 0,155 in<sup>2</sup>
- 1 hp = 0,746 kW
- 1 kW = 1,359 hp
- 1 kN = 225 lbs

### Imperial to metric

Inches	Decimal	mm
1/16	.06	1,59
1/8	.13	3,18
3/16	.19	4,76
1/4	.25	6,35
5/16	.31	7,94
3/8	.38	9,53
7/16	.44	11,11
1/2	.50	12,70
9/16	.56	14,29
5/8	.63	15,88
11/16	.69	17,46
3/4	.75	19,05
13/16	.81	20,64
7/8	.88	22,23
15/16	.94	23,81
1	1.00	25,40

# Cylinder Speed Charts



## Cylinder Speed

This chart will help you calculate the time required for an Enerpac cylinder to lift a load when powered by a 700 bar Enerpac hydraulic pump. The Cylinder Speed Chart can also be used to determine the pump type and model best suited for an application when you know the plunger speed required.

## To determine:

### Cylinder plunger speed

An RC-256 cylinder (25 ton) is powered by a ZE3-Series two stage pump. While lifting the load, the cylinder plunger travels at 2,8 mm per second. While extending towards the load,

the cylinder plunger travels at 30,9 mm per second.

30 ton		50 ton		75 ton		100 ton		Pump Serie/Type	
No Load	Load	No Load	Load	No Load	Load	No Load	Load		
145,5	4,0	26,9	2,3	18,7	1,6	14,4	1,3		ZU4-Series
2,3	2,2	1,4	1,3	1,0	0,9	0,7	0,7		ZE3 one stage
24,3	2,2	14,4	1,3	10,0	0,9	7,7	0,7		ZE3 two stage
3,4	3,2	2,0	1,9	1,4	1,3	1,1	1,0		ZE4 one stage
35,2	3,2	20,8	1,9	14,4	1,3	11,1	1,0		ZE4 two stage
6,9	6,5	4,1	3,8	2,8	2,7	2,2	2,1		ZE5 one stage
146,0	6,5	27,2	3,8	18,9	2,7	14,5	2,1		ZE5 two stage
									ZE6 one stage

## To determine:

### Best matching pump

Your 25 ton cylinder needs to move a load at a speed of 3,0 mm per second. Simply go down from the top of the chart, to the value of 2,8 mm per second. Follow the chart to the right

to find that the ZE3-Series pump is most suitable for your application.

30 ton		50 ton		75 ton		100 ton		Pump Serie/Type	
No Load	Load	No Load	Load	No Load	Load	No Load	Load		
145,5	4,0	26,9	2,3	18,7	1,6	14,4	1,3		ZU4-Series
2,3	2,2	1,4	1,3	1,0	0,9	0,7	0,7		ZE3 one stage
24,3	2,2	14,4	1,3	10,0	0,9	7,7	0,7		ZE3 two stage
3,4	3,2	2,0	1,9	1,4	1,3	1,1	1,0		ZE4 one stage
35,2	3,2	20,8	1,9	14,4	1,3	11,1	1,0		ZE4 two stage
6,9	6,5	4,1	3,8	2,8	2,7	2,2	2,1		ZE5 one stage
146,0	6,5	27,2	3,8	18,9	2,7	14,5	2,1		ZE5 two stage
									ZE6 one stage

## Millimetres of Cylinder Plunger Travel per Hand Pump Plunger Stroke

Cyl. Capacity ▶	5 ton		10 ton		15 ton		25 ton		30 ton		50 ton		75 ton		100 ton		Pump Type	Page:
	No Load	Load	No Load	Load	No Load	Load	No Load	Load	No Load	Load	No Load	Load	No Load	Load	No Load	Load		
▼ Power Source Manual	3,9	3,9	1,7	1,7	1,2	1,2	0,7	0,7	0,6	0,6	0,3	0,3	0,2	0,2	0,2	0,2	P-391	66
	17,6	3,9	7,8	1,7	5,5	1,2	3,4	0,7	2,6	0,6	1,6	0,3	1,0	0,2	0,8	0,2	P-392	66
	25,3	3,8	11,2	1,7	7,9	1,2	4,9	0,7	3,7	0,6	2,3	0,3	1,5	0,2	1,1	0,2	P-80/801/84	68
	61,4	3,9	27,1	1,7	19,3	1,2	11,8	0,7	9,0	0,6	5,5	0,3	3,5	0,2	2,8	0,2	P-802/842	68
	197	7,4	87,1	3,3	61,8	2,3	37,9	1,4	29,0	1,1	17,7	0,7	11,4	0,4	8,8	0,3	P-462/464	68

## Millimetres per Second of Cylinder Plunger Travel

Cyl. Capacity ▶	5 ton		10 ton		15 ton		25 ton		30 ton		50 ton		75 ton		100 ton		Pump Type	Page:
	No Load	Load	No Load	Load	No Load	Load	No Load	Load	No Load	Load	No Load	Load	No Load	Load	No Load	Load		
▼ Power Source Electric Pumps (speed based on 50Hz)	48	6,4	21,8	2,9	15,6	2,1	9,5	1,3	7,5	1,0	4,4	0,6	3,1	0,4	2,4	0,3	BP Battery Powered	76
	86	8,3	38	3,7	27	2,6	17	1,6	13	1,3	7,7	0,7	5,4	0,5	4,1	0,4	PU Economy	78
	53	7,1	24	3,2	17	2,2	10	1,4	8,1	1,1	4,8	0,6	3,3	0,4	2,6	0,3	PE Submerged	80
	295	25,6	132	11,5	94,4	8,2	57,7	5,0	45,5	4,0	26,9	2,3	18,7	1,6	14,4	1,3	ZU4-Series	84, 86
	15,1	14,1	6,8	6,3	4,8	4,5	3,0	2,8	2,3	2,2	1,4	1,3	1,0	0,9	0,7	0,7	ZE3 one stage	84, 92
	158	14,1	70,7	6,3	50,5	4,5	30,9	2,8	24,3	2,2	14,4	1,3	10,0	0,9	7,7	0,7	ZE3 two stage	84, 92
	22,3	21,0	10,0	9,4	7,1	6,7	4,4	4,1	3,4	3,2	2,0	1,9	1,4	1,3	1,1	1,0	ZE4 one stage	84, 92
	228	21,0	102	9,4	72,9	6,7	44,6	4,1	35,2	3,2	20,8	1,9	14,4	1,3	11,1	1,0	ZE4 two stage	84, 92
	44,9	42,1	20,1	18,9	14,4	13,5	8,8	8,2	6,9	6,5	4,1	3,8	2,8	2,7	2,2	2,1	ZE5 one stage	84, 92
	298	42,1	133	18,9	95,3	13,5	58,3	8,2	46,0	6,5	27,2	3,8	18,9	2,7	14,5	2,1	ZE5 two stage	84, 92
	76,9	70,0	34,5	31,4	24,6	22,4	15,1	13,7	11,9	10,8	7,0	6,4	4,9	4,4	3,8	3,4	ZE6 one stage	84, 92
	315	70,0	141	31,4	101	22,4	61,7	13,7	48,7	10,8	28,8	6,4	20,0	4,4	15,4	3,4	ZE6 two stage	84, 92
	64	64	28,7	28,7	20,5	20,5	12,6	12,6	9,9	9,9	5,9	5,9	4,1	4,1	3,1	3,1	PPM-9000-4	98
▼ Power Source Air Driven Pumps (at 6.9 bar air pressure)	51,3	6,4	23,0	2,9	16,4	2,1	10,0	1,3	7,9	1,0	4,7	0,6	3,2	0,4	2,5	0,3	XA-Series	100
	25,9	4,2	11,6	1,9	8,2	1,3	5,0	0,8	4,0	0,6	2,3	0,4	1,6	0,3	1,3	0,2	Turbo II Air	102
	17	3,4	7,6	1,5	5,4	1,1	3,3	0,7	2,6	0,5	1,5	0,3	1,1	0,2	0,8	0,2	PA-Series	104
	277	3,8	123	1,7	88	1,2	53	0,7	42	0,6	25	0,3	17	0,2	13,0	0,2	PAM-Series	105
	357	33,6	160	15,1	114	10,8	69,9	6,6	55,1	5,2	32,6	3,1	22,6	2,1	17,4	1,6	ZA-Series	106
▼ Power Source Gasoline Engine	85	17	38	7,6	27	5,4	16	3,3	13	2,6	7,7	1,5	5,3	1,1	4,1	0,8	PGM-20 Atlas	109
	295	41	132	18,4	94,4	13,1	57,7	8,0	45,5	6,3	26,9	3,7	18,7	2,6	14,4	2,0	ZG5-Series 4,1 kW	110
	166	41	74,7	18,4	53,4	13,1	32,6	8,0	25,7	6,3	15,2	3,7	10,6	2,6	8,1	2,0	ZG5-Series 4,8 kW	110
	376	85	169	37,9	121	27,1	73,8	16,6	58,2	13,1	34,4	7,7	23,9	5,4	18,4	4,1	ZG6-Series 9,7 kW	112

**No Load** indicates the plunger speed as the plunger extends towards the load (1st stage).

**Load** indicates the plunger speed as the load is lifted at a system pressure of 700 bar (2nd stage).

**Example:** At what speed (V) will the RC-256 (25 ton) cylinder move when powered by a ZE3-Series pump?

RC-256 Cylinder Effective Area = 33,2 cm<sup>2</sup>  
ZE3-Series pump oil Flow (no load) = 6150 cm<sup>3</sup>/min

$$\text{Speed } V = \frac{6150 \text{ cm}^3/\text{min} \times 10}{33,2 \times 60} = 30,9 \text{ mm/sec}$$

$$\text{Cylinder Plunger Speed (mm/sec)} = \frac{\text{Pump Oil Flow (cm}^3/\text{min)} \times 10}{\text{Cylinder Effective Area (cm}^2) \times 60}$$





# Valve Information

## Ways

The (oil) ports on a valve.

A 3-way valve has 3 ports: pressure (P), tank (T), and cylinder (A).

A 4-way valve has 4 ports: pressure (P), tank (T), advance (A) and retract (B).

**Single-Acting** cylinders require at least a 3-way valve, and can, under certain instances, be operated with a 4-way valve.

**Double-Acting** cylinders require a 4-way valve, providing control of the flow to each cylinder port.

## Positions

The number of control points a valve can provide. A 2-position valve has the ability to control only the advance or retraction of the cylinder. To be able to control the cylinder with a hold position, the valve requires a 3rd position.

## Centre Configuration

The centre position of a valve is the position at which there is no movement required of the hydraulic component, whether a tool or cylinder.

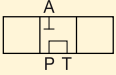

The most common is the **Tandem Centre**. This configuration provides for little to no movement of the cylinder and the unloading of the pump. This provides for minimum heat build-up.

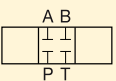

The next most common is the **Closed Centre** configuration, which is used mostly for independent

control of multi-cylinder applications. This configuration again provides for little to no movement of the cylinder, but also dead-heads the pump, isolating it from the circuit. Use of this type of valve may require some means of unloading the pump to prevent heat build-up.

There are many more type of valves, such as Open Centre and Float Centre. These valves are used mostly in complex hydraulic circuits and require other special considerations.

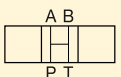

Open Centre



Float Centre

## Directional Control Valves

**3-Way Valves** are used with single-acting cylinders.

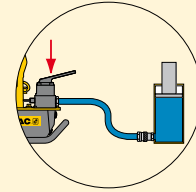

**4-Way Valves** are used with double-acting cylinders.

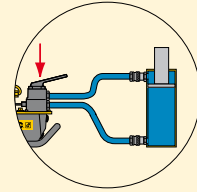

Valves may be either pump mounted or remote mounted.

## Pump Mounted

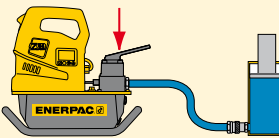

## Remote Mounted

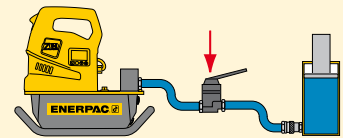

Valves may be either manually or solenoid operated.

## Manually Operated

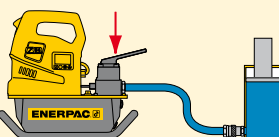

## Solenoid Operated

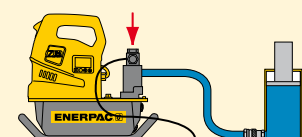

## Advance Hold Retract

**Single-acting cylinder** Controlled by a 3-way, 3-position valve.

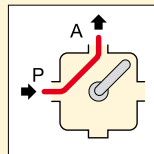

### Advance

The oil flows from the pump pressure port P to the cylinder port A: the cylinder plunger will extend.

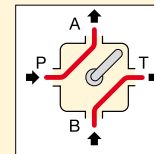

### Advance

The oil flows from the pump pressure port P to the cylinder port A and from cylinder port B to tank T.

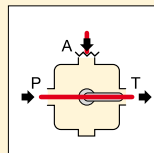

### Hold

The oil flows from the pump pressure port P to the tank T. The cylinder port A is closed: the cylinder plunger will maintain its position.

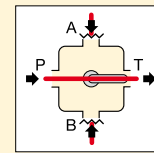

### Hold

The oil flows from the pump pressure port P to the tank T. The cylinder ports A and B are closed: the cylinder plunger will maintain position.

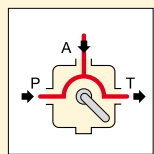

### Retract

The oil flows from the pump and cylinder port A to the tank T: the cylinder plunger will retract.

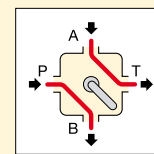

### Retract

The oil flows from the pump pressure port P to cylinder port B and from cylinder port A to tank T: the cylinder plunger will retract.



ENERPAC products are warranted to be free of defects in materials and workmanship under normal use for as long as they are owned by the original purchaser, subject to the exclusions and limitations described below. This warranty does not cover ordinary wear and tear, overloading, alterations, (including repairs or attempted repairs by parties other than ENERPAC or its authorised service representatives), improper fluid, use in a manner for which they are not intended or use which is contrary to instructions for the products.

THIS WARRANTY IS LIMITED TO NEW PRODUCTS SOLD THROUGH ENERPAC AUTHORISED DISTRIBUTORS, ORIGINAL EQUIPMENT MANUFACTURERS OR OTHER DESIGNATED CHANNELS OF DISTRIBUTION. NO AGENT, EMPLOYEE, OR OTHER REPRESENTATIVE OF ENERPAC HAS THE AUTHORITY TO IN ANY WAY CHANGE OR AMEND THIS WARRANTY.

Electronic products and components are warranted against defects in material and workmanship for a period of two years from the date of purchase.

The following items supplied with ENERPAC products are excluded from this warranty:

- Components not manufactured by ENERPAC, including air motors, electric motors, gasoline engines, and diesel engines. Such items are warranted to the extent of the warranty provided by the manufacturers of such items.
- Consumable items, including cutter blades, nut splitter chisels, punches and dies.
- Chains.

If the customer believes a product is defective, the product must be delivered, or shipped freight prepaid, to the nearest ENERPAC Authorised Service Center. The customer should contact ENERPAC to locate an Authorised Service Center in the customer's area. Products that do not conform to this warranty will be repaired or replaced at ENERPAC's expense and returned by ground transportation, freight prepaid.

THE FOREGOING WARRANTY IS EXCLUSIVE AND IS IN LIEU OF ALL OTHER EXPRESS AND IMPLIED WARRANTIES, INCLUDING BUT NOT LIMITED TO THE IMPLIED WARRANTIES OF MERCHANTABILITY AND FITNESS FOR A PARTICULAR PURPOSE.

The remedy of repair, replacement or refund is customer's exclusive remedy in the event of breach of this warranty.

SELLER SHALL NOT BE SUBJECT TO AND DISCLAIMS:

- (a) ANY OTHER OBLIGATIONS OR LIABILITIES ARISING OUT OF BREACH OF CONTRACT OR OF WARRANTY,
- (b) ANY OBLIGATIONS WHATSOEVER ARISING FROM TORT CLAIMS (INCLUDING NEGLIGENCE AND STRICT LIABILITY) OR ARISING UNDER THEORIES OF LAW WITH RESPECT TO PRODUCTS SOLD OR SERVICES RENDERED BY SELLER OR ANY UNDERTAKINGS, ACTS OR OMISSIONS RELATING THERETO, AND
- (c) ALL CONSEQUENTIAL, INCIDENTAL AND CONTINGENT DAMAGES WHATSOEVER.

ENERPAC's liability in all cases is limited to, and shall not exceed, the purchase price paid.

Effective June 1, 1997



# Torque Tightening

## Tightening Methods

Principally there are two modes of tightening: "Uncontrolled" and "Controlled".

### Uncontrolled tightening

Uses equipment and/or procedures that cannot be measured. Preload is applied to a bolt and nut assembly using a hammer and spanner or other types of impact tools.

### Controlled tightening

Employs calibrated and measurable equipment, follows prescribed procedures and is carried out by trained personnel.

## Advantages of Controlled Tightening

### Known, controllable and accurate bolt loads

Employs tooling with controllable outputs and adopts calculation to determine the required tool settings.

### Uniformity of bolt loading

Especially important on gasketed joints as an even and consistent compression is required for the gasket to be effective.

### Safe operation following prescribed procedures

Eliminates the dangerous activities of manual uncontrolled tightening and requires that the operators be skilled and follow procedures.

### Reduces operational time resulting in increased productivity

Reduces tightening time and operator fatigue by replacing manual effort with the use of controlled tooling.

### Reliable and repeatable results

Using calibrated, tested equipment, following procedures and employing skilled operators achieves known results consistently.

### The right results first time

Many of the uncertainties surrounding in-service joint failures are removed by ensuring the correct assembly and tightening of the joint the first time.



## Bolting Solutions

For further information on Torque Tightening or other controlled tightening methods, please visit our website or ask for our Bolting Solutions Catalogue **E410e**.

## Bolting Integrity Software

A comprehensive free on-line software solution for Bolted Joint Integrity. Integral databases hold data for:

- BS1560, MSS SP44, API 6A and 17D flanged joints
- Common gasket materials and configurations
- Comprehensive range of bolt materials
- Comprehensive range of lubricants
- Enerpac's Controlled Bolting Equipment including: Torque Multipliers, Hydraulic Wrenches and Bolt Tensioning tools.

Custom Joint information can also be entered.

The software offers Tool selection, Bolt Load calculations and Tool pressure settings, as well as a combined Application data sheet and Joint completion report.

## What is Torque?

It is a measure of how much force acting on an object causes that object to rotate.

## What is Torque Tightening?

The application of preload to a fastener by the turning of the fastener's nut.

## Torque Tightening and Preload

The amount of preload created when torqueing is largely dependant on the effects of friction.

Principally there are three different "torque components":

- torque to stretch the bolt
- torque to overcome the friction in bolt and nut threads
- torque to overcome friction at the nut spot face (bearing contact surface).

## Torque Tightening

Turning movement

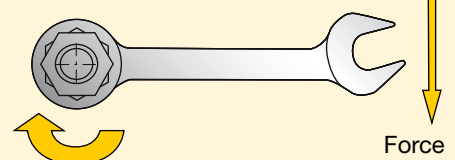

Stretch of Fastener (Pre-load)

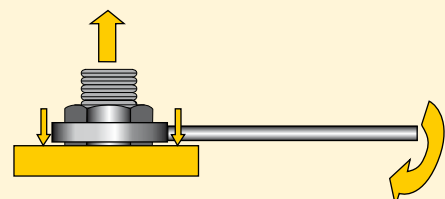



**Preload (residual load) = Applied Torque *minus* Frictional Losses**

## Lubrication Reduces Friction

Lubrication reduces the friction during tightening, decreases bolt failure during installation and increases bolt service life. Variation in friction coefficients affect the amount of preload achieved at a specified torque. Higher friction results in less conversion of torque to preload. The value for the friction coefficient provided by the lubricant manufacturer must be known to accurately establish the required torque value.

Lubricant or anti-seizure compounds should be applied to both, the nut bearing surface and the male threads.

## Frictional Losses

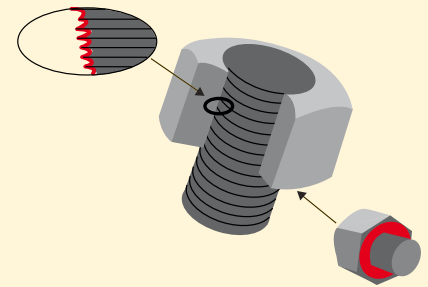
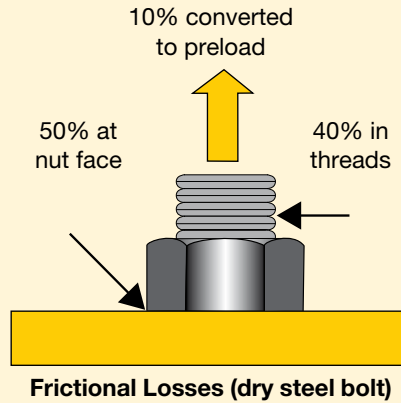

*Friction points should always be lubricated when using the torque tightening method.*



## Select the Right Torque Wrench

Choose your Enerpac torque wrench using the untightening rule of thumb:

- When loosening a nut or bolt, more torque is usually required than when tightening.
- For general conditions it can take up to **2½ times** the input torque to breakout.
- Do not apply more than 75% of the maximum torque output of the tool when loosening nuts or bolts.

## Conditions of bolted joints

- Humidity corrosion (rust) requires up to **twice** the torque required for tightening.
- Sea water and chemical corrosion requires up to **2½ times** the torque required for tightening.
- Heat corrosion requires up to **3 times** the torque required for tightening.

## Torque Procedure

When torquing it is common to tighten only one bolt at a time, which can result in Point Loading and Load Scatter.

To avoid this, torque is applied in stages following a prescribed pattern:

## Torque Sequence

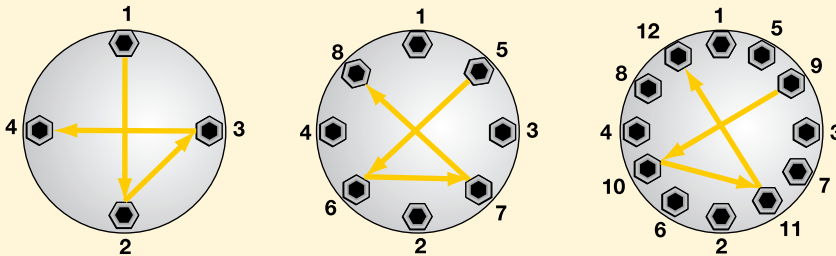

**Step 1** Spanner tight ensuring that 2 - 3 threads extend above nut

**Step 2** Tighten each bolt to one-third of the final required torque following the pattern as shown above.

**Step 3** Increase the torque to two-thirds following the pattern shown above.

**Step 4** Increase the torque to full torque following the pattern shown above.

**Step 5** Perform one final pass on each bolt working clockwise from bolt 1, at the full final torque.



## Breakout Torque

When loosening bolts a torque value higher than the tightening torque is normally required. This is mainly due to corrosion and deformations in the bolt and nut threads. Breakout torque cannot be accurately calculated, however, depending on conditions it can take up to **2½ times** the input torque to breakout.

The use of penetrating oils or anti-seize products is always recommended when performing breakout operations.



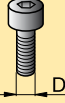
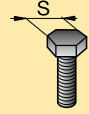
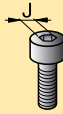

# Hexagon Nut and Bolt Sizes

METRIC SIZES		
		
Thread Size D (mm)	Hexagon Size S (mm)	Hexagon Size J (mm)
M 10	17	8
M 12	19	10
M 14	22	12
M 16	24	14
M 18	27	14
M 20	30	17
M 22	32	17
M 24	36	19
M 27	41	19
M 30	46	22
M 33	50	24
M 36	55	27
M 39	60	27 (30)
M 42	65	32
M 45	70	-
M 48	75	36
M 52	80	36
M 56	85	41
M 60	90	46
M 64	95	46
M 68	100	50
M 72	105	55
M 76	110	60
M 80	115	65
M 85	120	70
M 90	130	70 (75)
M 95	135	-
M 100	145	85
M 105	150	-
M 110	155	-
M 115	165	-
M 120	170	-
M 125	180	-
M 130	185	-
M 140	200	-
M 150	210	-

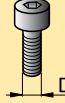
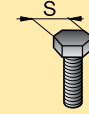
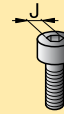
IMPERIAL SIZES		
		
Thread Size D (inch)	Hexagon Size * S (inch)	Hexagon Size J (inch)
5/8"	1 1/16"	1/2"
3/4"	1 1/4"	5/8"
7/8"	1 7/16"	3/4"
1"	1 5/8"	3/4"
1 1/8"	1 13/16"	7/8"
1 1/4"	2"	7/8"
1 3/8"	2 3/16"	1"
1 1/2"	2 3/8"	1"
1 5/8"	2 9/16"	-
1 3/4"	2 3/4"	1 1/4"
1 7/8"	2 15/16"	1 3/8"
2"	3 1/8"	1 5/8"
2 1/4"	3 1/2"	1 3/4"
2 1/2"	3 7/8"	1 7/8"
2 3/4"	4 1/4"	2"
3"	4 5/8"	2 1/4"
3 1/4"	5"	2 1/4"

\* Heavy hexagon nuts.



Determine the maximum torque according to the bolt (nut) size and grade. Always consult the manufacturers instructions or engineering recommendations when making bolted connections.



### IMPORTANT

The hexagon sizes shown in the tables should be used as a guide only. Individual sizes should be checked before specifying any equipment.



### BSH-Series Sockets

Use only Heavy Duty Impact Sockets for power driven torquing equipment, according to ISO2725 and

ISO1174; DIN3129 and DIN3121 or ASME-B107.2/1995.



ENERPAC manufactures high-force hydraulics (cylinders, pumps, valves, presses, pullers, tools, accessories and system components) for industry and construction and provides hydraulic workholding and OEM solutions to industries worldwide.

With an 80-year history of quality and innovation, the broadest line in the business, and more than 4000 distributors and factory-trained service centers around the world, Enerpac leads the industry by setting new standards in design, strength, durability and local support. Strict quality programs, zero tolerance for defects, and ISO-9001 certification are your assurance of safe, trouble-free operation.

Enerpac is ready to tackle your toughest challenge and provide the hydraulic advantage you need to increase productivity, labour efficiency and speed of operation.

While every care has been taken in the preparation of this catalogue and all data contained within is deemed accurate at the time of printing, Enerpac does reserve the right to make changes to the specifications of any product, or discontinue any product, contained within this catalogue without prior notice.

All illustrations, performance specifications, weights and dimensions reflect the nominal values and slight variations may occur due to manufacturing tolerances. Please consult Enerpac if final dimensions are critical. All information in this catalogue can be changed due to product improvements without prior notice.

© Copyright 2010, Enerpac.  
All rights reserved. Any copying or other use of material in this catalogue (text, illustrations, drawings, photo's) without express written consent is prohibited.

### Worldwide Catalogue Coverage

Enerpac Catalogues are printed in many languages. If your requirements call for product use in a different country, please send your request to the applicable country listed on page 256 or [www.enerpac.com](http://www.enerpac.com) – the Enerpac catalogue of the country serving your specific market area will be forwarded promptly.

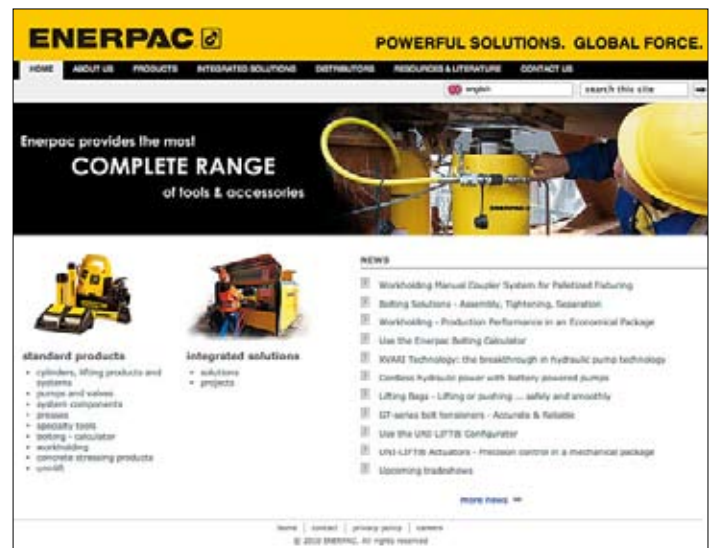

### www.enerpac.com for latest Enerpac information

Visit the Enerpac Web Site:

- Learn more about hydraulics
- Promotions
- New products
- Electronic Catalogs
- Trade shows
- Manuals (instruction and repair sheets)
- Nearest Distributors & Service Centers
- Enerpac products in action
- Integrated Solutions.

### Ordering Products and Catalogs

To find the name of the closest Enerpac distributor or service center, to request literature or technical application assistance, contact Enerpac at one of the addresses on the next page or pose your question through E-mail: [info@enerpac.com](mailto:info@enerpac.com)

### Enerpac catalogues & brochures to meet your needs:

To obtain your copy just give us a call, or visit our Internet site.

#### E410e, Bolting Solutions Catalogue

Caters to the complete bolting workflow, ensuring joint integrity in a variety of applications throughout industry, including: joint assembly, controlled tightening and joint separation.



#### 8200 GB, Solutions & Systems for the Wind Power Industry

Enerpac is the natural choice for providing tools, solutions and systems to the wind power industry. Capability brochure about core technologies: High-force industrial tools, bolting solutions and integrated positioning systems.



#### E213e, Workholding Catalogue

Offers innovative products and solutions to provide powerful clamping and positioning force to every type of manufacturing process. Workholding solutions increase product quality and production output.





# Enerpac Worldwide Locations

**ENERPAC**   
POWERFUL SOLUTIONS. GLOBAL FORCE.

## Africa

ENERPAC Middle East FZE  
Office 423, JAFZA 15  
P.O. Box 18004  
Jebel Ali, Dubai  
United Arab Emirates  
Tel: +971 (0)4 8872686  
Fax: +971 (0)4 8872687

## Australia and New Zealand

Actuant Australia Ltd.  
Block V Unit 3  
Regents Park Estate  
391 Park Road  
Regents Park NSW 2143  
(P.O. Box 261) Australia  
Tel: +61 297 438 988  
Fax: +61 297 438 648

## Brazil

Power Packer do Brasil Ltda.  
Rua dos Inocentes, 587  
04764-050 - Sao Paulo (SP)  
Tel: +55 11 5687 2211  
Fax: +55 11 5686 5583  
Toll Free: 0800 891 5770  
vendasbrasil@enerpac.com

## Canada

Actuant Canada Corporation  
6615 Ordan Drive, Unit 14-15  
Mississauga, Ontario L5T 1X2  
Tel: +1 905 564 5749  
Fax: +1 905 564 0305  
Toll Free:  
Tel: +1 800 268 4987  
Fax: +1 800 461 2456  
Technical Inquiries:  
techservices@enerpac.com

## China

Actuant Industries Co. Ltd.  
No. 6 Nanjing Road,  
Taicang Economic Dep Zone  
Jiangsu, China  
Tel: +86 0512 5328 7529  
+86 0512 5328 7500  
Fax: +86 0512 5335 9690

## Actuant China Ltd. (Peking)

709B Diyang Building  
Xin No. 2  
Dong San Huan North Rd.  
Beijing City, 100028 China  
Tel: +86 10 845 36166  
Fax: +86 10 845 36220

## France and Switzerland

ENERPAC Une division de  
ACTUANT France S.A.S.  
ZA de Courtaboeuf  
32, avenue de la Baltique  
91140 VILLEBON /YVETTE  
France  
Tel: +33 1 60 13 68 68  
Fax: +33 1 69 20 37 50

## Germany, Austria, Greece, Baltic States, Central and Eastern Europe

ENERPAC GmbH  
P.O. Box 300113  
D-40401 Düsseldorf  
Willstätterstrasse 13  
D-40549 Düsseldorf, Germany  
Tel: +49 211 471 490  
Fax: +49 211 471 49 28

## India

ENERPAC Hydraulics Pvt. Ltd.  
No. 1A, Peenya Industrial Area  
II<sup>nd</sup> Phase, Bangalore, 560 058  
India  
Tel: +91 80 40 792 777  
Fax: +91 80 40 792 792

## Italy

ENERPAC S.p.A.  
Via Canova 4  
20094 Corsico (Milano)  
Tel: +39 02 4861 111  
Fax: +39 02 4860 1288

## Japan

Applied Power Japan LTD KK  
Besshocho 85-7  
Kita-ku, Saitama-shi 331-0821, Japan  
Tel: +81 48 662 4911  
Fax: +81 48 662 4955

## Middle East, Turkey and Caspian Sea

ENERPAC Middle East FZE  
Office 423, JAFZA 15  
P.O. Box 18004, Jebel Ali, Dubai  
United Arab Emirates  
Tel: +971 (0)4 8872686  
Fax: +971 (0)4 8872687

## Russia and CIS

(excl. Caspian Sea Countries)  
Actuant LLC  
Admiral Makarov Street 8  
125212 Moscow, Russia  
Tel: +7-495-9809091  
Fax: +7-495-9809092

## Singapore

Actuant Asia Pte Ltd.  
37C, Benoi Road Pioneer Lot,  
Singapore 627796  
Tel: +65 68 63 0611  
Fax: +65 64 84 5669  
Toll Free: Tel: +1800 363 7722  
Technical Inquiries:  
techsupport@enerpac.com.sg

## South Korea

Actuant Korea Ltd.  
3Ba 717, Shihwa Industrial Complex  
Jungwang-Dong, Shihung-Shi,  
Kyunggi-Do  
Republic of Korea 429-450  
Tel: +82 31 434 4506  
Fax: +82 31 434 4507

## Spain and Portugal

ENERPAC SPAIN, S.L.  
Avda. Los Frailes, 40 – Nave C & D  
Pol. Ind. Los Frailes  
28814 Daganzo de Arriba  
(Madrid) Spain  
Tel: +34 91 884 86 06  
Fax: +34 91 884 86 11

## Sweden, Denmark, Norway, Finland and Iceland

Enerpac Scandinavia AB  
Fabriksgatan 7  
412 50 Gothenburg  
Sweden  
Tel: +46 (0) 31 7990281  
Fax: +46 (0) 31 7990010  
Inquiries:  
Scandinavianinquiries@enerpac.com

## The Netherlands, Belgium and Luxembourg

ENERPAC B.V.  
Galvanistraat 115  
6716 AE Ede  
P.O. Box 8097  
6710 AB Ede  
The Netherlands  
Tel: +31 318 535 800  
Fax: +31 318 525 613  
+31 318 535 848  
Inquiries:  
beneluxinquiries@enerpac.com

## ENERPAC Roermond B.V.

Daalakkerweg 24  
6041 BL Roermond  
P.O. Box 49  
6040 AA Roermond  
The Netherlands  
Tel: +31 475 355 000  
Fax: +31 475 331 774

## United Kingdom and Ireland

ENERPAC Ltd.,  
Bentley Road South  
Darlaston, West Midlands  
WS10 8LQ  
England  
Tel: +44 (0)121 50 50 787  
Fax: +44 (0)121 50 50 799

## USA, Latin America and Caribbean

ENERPAC  
P.O. Box 3241  
6100 N. Baker Road  
Milwaukee  
WI 53209 USA  
Tel: +1 262 781 6600  
Fax: +1 262 783 9562  
User inquiries:  
+1 800 433 2766  
Distributor inquiries/orders:  
+1 800 558 0530  
Technical Inquiries:  
techservices@enerpac.com

# Model Number Index

# Section Index

Page(s) ▼ Page(s) ▼ Page(s) ▼ Page(s) ▼

<b>A</b>	<b>D</b>	<b>N</b>	<b>STF</b> ..... 217-218
A5-A10 ..... 166	DGR ..... 131	NC ..... 219	STN ..... 219
A12 ..... 10	<b>E</b>	NS ..... 220-221	STP ..... 169
A13-A28 ..... 166	E ..... 186-187	NV ..... 132	STV ..... 144
A29-A53 ..... 10	EBJ ..... 57	<b>P</b>	SW ..... 217
A64-A66 ..... 124	ELP ..... 174-175	P ..... 66-71, 73	<b>T</b>
A92 ..... 166, 177	EMB ..... 174	..... 74-75	T ..... 123, 130
A102 ..... 10	EP ..... 154-157	P142AL ..... 60-61	TH ..... 194, 202-203
A128-A192 ..... 166	EPH ..... 158-161	P392AL ..... 60-61	..... 207, 209-214
A183 ..... 142	EPP ..... 155, 157	P392FP ..... 73	TM ..... 147
A185 ..... 142, 166	EPS ..... 226-227	PA ..... 102-104	TW ..... 216
A200R ..... 146	EPT ..... 157	PAM ..... 105	<b>V</b>
A205-A220 ..... 142	EPX ..... 163	PAMG ..... 102-103	V ..... 60-61, 134-135
A218 ..... 166	ER ..... 174-175	PATG ..... 102-103	VA2 ..... 105
A242-A305 ..... 166	ES ..... 174-175	PARG ..... 102-103	VB ..... 139, 146
A310, A330 ..... 142	ESS ..... 224-225	PC ..... 66, 68, 70	VC ..... 116-117
A530-A595 ..... 166	<b>F</b>	PE ..... 80-83	VE ..... 114-117
A604 ..... 122-123	F ..... 122-123	PF25 ..... 94	VHJ ..... 146
A607 ..... 166	FH ..... 122-123	PGM ..... 109	VLP ..... 138-139
A630 ..... 122-123	FR ..... 122-123	PM ..... 202-203	VM ..... 114-117
A650 ..... 166	FS ..... 218	PP ..... 98-99	<b>W</b>
AH ..... 122-123	FSB ..... 172, 217	PR ..... 58-59	W ..... 194-201
AM ..... 124	FSH ..... 217	PTJ ..... 182-183	WC ..... 178-179
AR ..... 122-123	FSM ..... 217	PTA ..... 202, 210-211	WH ..... 178
ATM ..... 216	FZ ..... 125	PU ..... 78-79	WM ..... 179
ATP ..... 208	<b>G</b>	<b>R</b>	WR ..... 167, 177
AW ..... 10	G ..... 126-127	RA ..... 11	WRP ..... 201
<b>B</b>	GA ..... 132	RAC ..... 12-13	WTE ..... 201
B ..... 108, 236-238	GF ..... 126-127	RACH ..... 16-17	<b>X</b>
BAD ..... 31	GP ..... 126-127	RACL ..... 14-15	XA ..... 100-101
BFZ ..... 125	<b>H</b>	RAR ..... 18-19	XLK ..... 100
BH ..... 108	H ..... 120-121	RB ..... 10	XLP ..... 138-139
BHP ..... 150-153	..... 132-133	RC ..... 6-9, 60-61	XPG ..... 100
BLS ..... 232-233	HA ..... 121	RCH ..... 26-27	XSC ..... 100, 125
BP ..... 76-77	HB ..... 121	RCS ..... 22-23	<b>Z</b>
BPR ..... 140-141	HC ..... 121	RE ..... 10	Z ..... 123
BR ..... 108	HF ..... 124	RFL ..... 101-105	ZA4 ..... 106-107
BRC ..... 24-25	HP ..... 27, 29	RR ..... 32-35	ZA4T ..... 202
BRD ..... 30-31	HT ..... 108	RRH ..... 28-29	..... 212-215
BRP ..... 24-25	<b>I</b>	RSM ..... 22-23	ZC ..... 88, 94-95
BRP ..... 24-25	IPL ..... 146	RTE ..... 191	ZE ..... 92-97
BSH ..... 192	<b>J</b>	RWH ..... 150	..... 208-209
BSS ..... 92, 106, 146	JBI ..... 10	<b>S</b>	ZG ..... 110-112
BV ..... 144-145	JH ..... 56	S ..... 188-191	ZH ..... 89, 95, 206
BW ..... 108	<b>L</b>	SB ..... 172, 217	ZL ..... 88, 94
BZ ..... 180-181	LB ..... 52-53	SBZ ..... 88, 94	ZP ..... 89, 94
<b>C</b>	LH ..... 147	..... 206, 214	ZU4 ..... 86-91
C ..... 122-123	LPC ..... 54-55	SC ..... 62-63	ZU4T ..... 202
CAT ..... 10, 23, 39	LW ..... 172	SCJ ..... 182-183	..... 204-206
..... 43, 47, 51	<b>M</b>	SDA ..... 190	ZR ..... 88, 94, 214
CATG ..... 13, 15, 19	M ..... 236-238	SHS ..... 234-235	<b>10</b>
..... 39, 47	MP ..... 72	SL ..... 56-57	5DA ..... 182-183
CD ..... 123	MS ..... 164-167	SLS ..... 54-55	11 ..... 74-75
CH ..... 123	MSP ..... 169	SOH ..... 173	40 ..... 183
CH ..... 123	MZ ..... 164-167	SP ..... 168-171	41-43-45 ..... 75
CLL ..... 48-51	<b>N</b>	SPD ..... 169	72- ..... 74-75
CLP ..... 20-21	..... 217-218	SPK ..... 168	83- ..... 75
CLRG ..... 44-47	<b>O</b>	SRS ..... 191	
CLS ..... 40-43	5DA ..... 182-183	STB ..... 180-181	
CLSG ..... 36-39	11 ..... 74-75	STC ..... 217-218	
CM ..... 176	40 ..... 183		
CM ..... 176	41-43-45 ..... 75		
CR ..... 122-123	72- ..... 74-75		
CW ..... 166	83- ..... 75		

## Cylinders & Lifting Products



Page 4-63

## Pumps & Directional Control Valves



Page 64-117

## System Components & Control Valves



Page 118-135

## Presses



Page 136-147

## Pullers



Page 148-161

## Tools



Page 162-183

## Bolting Tools



Page 184-221

## Integrated Solutions



Page 222-238





## Cylinders & Lifting Products

Page 4-63



## Pumps & Directional Control Valves

Page 64-117



## System Components & Control Valves

Page 118-135



## Presses

Page 136-147



## Pullers

Page 148-161



## Tools

Page 162-183



## Bolting Tools

Page 184-221



## Integrated Solutions

Page 222-238

### Africa

ENERPAC Middle East FZE  
Tel: +971 (0)4 8872686 – Fax: +971 (0)4 8872687

### Australia and New Zealand

Actuant Australia Ltd.  
Tel: +61 297 438 988 – Fax: +61 297 438 648

### Brazil

Power Packer do Brasil Ltda.  
Tel: +55 11 5687 2211 – Fax: +55 11 5686 5583  
Toll Free: 0800 891 5770

### Canada

Actuant Canada Corporation  
Tel: +1 905 564 5749 – Fax: +1 905 564 0305  
Toll Free:  
Tel: +1 800 268 4987 – Fax: +1 800 461 2456

### China

Actuant China Ltd.  
Tel: +86 21 5866 9099 – Fax: +86 21 5866 7156  
Tel: +86 10 845 36166 – Fax: +86 10 845 36220

### France and Switzerland

ENERPAC, Une division de ACTUANT France S.A.S.  
Tel: +33 1 60 13 68 68 – Fax: +33 1 69 20 37 50

### Germany, Austria, Greece, Baltic States, Central and Eastern Europe

ENERPAC GmbH  
Tel: +49 211 471 490 – Fax: +49 211 471 49 28

### India

ENERPAC Hydraulics (India) Pvt. Ltd.  
Tel: +91 80 40 792 777 – Fax: +91 80 40 792 792

### Italy

ENERPAC S.p.A.  
Tel: +39 02 4861 111 – Fax: +39 02 4860 1288

### Japan

Applied Power Japan LTD KK  
Tel: +81 48 662 4911 – Fax: +81 48 662 4955

### Middle East, Turkey and Caspian Sea

ENERPAC Middle East FZE  
Tel: +971 (0)4 8872686 – Fax: +971 (0)4 8872687

### Russia and CIS (excl. Caspian Sea Countries)

Tel: +7-495-9809091 – Fax: +7-495-9809092

### Singapore

Actuant Asia Pte. Ltd.  
Tel: +65 6863 0611 – Fax: +65 6484 5669  
Toll Free: +1800 363 7722

### South Korea

Actuant Korea Ltd.  
Tel: +82 31 434 4506 – Fax: +82 31 434 4507

### Spain and Portugal

ENERPAC Spain, S.L.  
Tel: +34 (0)91 661 11 25 – Fax: +34 (0)91 661 47 89

### Sweden, Denmark, Norway, Finland and Iceland

ENERPAC Scandinavia AB  
Tel: +46 (0)31 7990281 – Fax: +46 (0)31 7990010

**TIFOR Kft.**

**Attila u. 101.**

**1012 Budapest**

**tel 06 1 212 99 58**

**fax 06 1 375 49 79**

**eMail [info@tifor.hu](mailto:info@tifor.hu)**

**[www.tifor.hu](http://www.tifor.hu)**