

**ENERPAC** 

**TIFOR Kft.**  
**Attila u. 101.**  
**1012 Budapest**  
tel 06 1 212 99 58  
fax 06 1 375 49 79  
eMail [info@tifor.hu](mailto:info@tifor.hu)  
[www.tifor.hu](http://www.tifor.hu)

# Integrated Solutions

## Controlled Hydraulic Movement



- Synchronous Lifting Systems
- Weighing and COG determination
- Heavy Lifting Strand Jack Systems
- Bridge Launching Systems
- Skidding Systems

With more than 50 years of experience, Enerpac has gained unique expertise which is acknowledged by industrial and construction professionals around the world. In addition to standard products and components, Enerpac specializes in the design, manufacture and supply (sale & rental) of high-force hydraulic systems required for the precise controlled movement of heavy structures.

Engineers and construction experts consult with Enerpac to develop integrated hydraulic solutions, which have included:

- The incremental launching equipment for the tallest bridge in the world – le Viaduct de Millau (France),
- Construction solutions for the China Olympics – Beijing’s National Stadium, the world’s largest steel structure and the retractable roof system for the Nantong Olympic Stadium.
- Automatic foundation leveling systems for offshore wind turbines,
- Strand jacking equipment for construction, oil & gas and industrial heavy lifting applications.

Across every continent Enerpac has presence through local offices, including application engineers, authorized distributors and service centers to deliver innovative solutions and technical assistance.

The deciding factor to choose for Enerpac resides on a history of supply of quality products & systems as well as a strong relationship with customers, Enerpac local representation and an excellent back-up in technical support on a global front.





# Integrated Solutions Section Overview

Capacity ton (kN)	Capabilities	Series	Page
N/A	<b>Synchronous Lifting Systems</b> Standard 4 to 16 point lift system	ESS	4 ▶
N/A	<b>Synchronous Lifting Systems</b> Premium 4 to 64 point lift system	EPS	6 ▶
37 - 673 (360 - 6600)	<b>Heavy Lifting Strand Jack Systems</b> Accurate lifting, lowering or horizontal movements of heavy loads	TT	8 ▶
5,5 - 37 kW	<b>Strand Jack Hydraulic Pumps</b> <b>Master PLC-Control Units</b> Control multiple strand jacks & pumps	TTP	10 ▶ 11 ▶
50 - 200 (498 - 1995)	<b>Stage Lifting Systems</b> Incremental lifting	BLS	12 ▶
60 - 110 (605 - 1110)	<b>Synchronous Hoisting Systems</b> SynchHoist – hydraulic precision positioning systems	SHS	14 ▶
0,25 - 250 (2,2 - 2222)	<b>Uni-Lift® Actuators</b> Mechanical precision positioning	M B	16 ▶

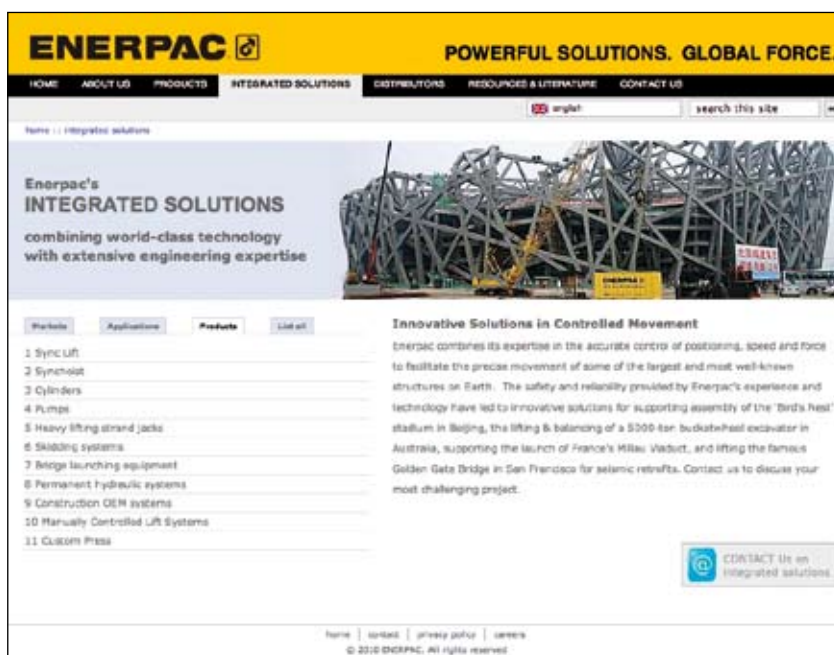

## Contact Enerpac!

Contact the Enerpac office nearest to you for advice and technical assistance in the layout of your ideal Lifting System or visit us at: [www.enerpac.com](http://www.enerpac.com).

Or ask Enerpac for assistance by email: [integratedsolutions@enerpac.com](mailto:integratedsolutions@enerpac.com).

# Standard 4 to 16 Point Lifting System

▼ **ESS-Series 8-point Synchronous Lifting System** (shown without cylinders)



- **Stroke and load controlled movement for positioning and weighing**
- **Measurement accuracy better than 1,0 mm between leading and lagging cylinders**
- **Data storage and recording capabilities**
- **Load and stroke alarms for optimal safety**
- **For use with standard single or double-acting cylinders**
- **Integrated 700 bar hydraulic pump and controls.**



▼ *Synchronous system lifted and monitored the load of the bridge as pier heads were rebuilt for wider traffic lanes, while highway below and the railway on top of this bridge were kept operational.*



## Controlled Hydraulic Movement for Positioning and Weighing



### Typical Synchronous Lifting Applications

- Lifting, lowering, weighing of heavy structures
- Centre of gravity measurement
- Bridge maintenance
- Deck lifting & bearing replacement
- De-propping/load transfer from temporary steel work
- Heavy plant installation
- Incremental bridge launching & box jacking
- Pile testing
- Foundation shoring.



### Contact Enerpac!

Contact the Enerpac office nearest to you for advice and technical assistance in the layout of your ideal Lifting System or visit us at: [www.enerpac.com](http://www.enerpac.com).

Or ask Enerpac for assistance by email: [integratedsolutions@enerpac.com](mailto:integratedsolutions@enerpac.com).



### Lifting Cylinders

For a complete line of Enerpac cylinders, see the Cylinder and Lifting Products Section of our **E326e** catalogue.



### Premium Synchronous Lifting Systems

For networking, data storage, preprogrammable and recording functions, graphical representation and up to 64 lifting points see the **EPS-Series** Synchronous Lifting System.

# Standard 4 to 16 Point Synchronous Lifting System



## Synchronous Lifting

The synchronous lift system uses feedback from multiple sensors to control the lifting, lowering and positioning of any large, heavy or complex structure, regardless of weight distribution.

Synchronous lifting reduces the risk of bending, twisting or tilting, due to uneven weight distribution or load-shifts between the lift points.

A PLC controller monitors each lift position stroke and optional load transducers located at each lift point. By varying the oil flow to each lift point, the system maintains very accurate positional control.

This control maintains structural integrity and can increase the productivity and safety of the lift, by eliminating manual intervention in the event of a load-shift or other problem.

Programmable and failsafe monitoring and safety alarms include operating parameters and hydraulic conditions, such as oil-level and over-temperature.

Programmable data recording and "differential-lift" options allow a load to be manipulated into a pre-set position.

## ESS Series



Number of Lifting Points:  
**4, 8, 12 or 16**

Accuracy Over Full Stroke:  
**± 1,0 mm**

Maximum Operating Pressure:  
**700 bar**



### ▼ Touch screen display of ESS-Series synchronous lifting PLC-controller

ENERPAC		Selected Load		MENU	
Total Load	0000.0 KN			0000.0 KN	
Absolute Position	0000.0 mm	CYL 1	CYL 2	CYL 3	CYL 4
Relative Position	0000.0 mm	0000.0	0000.0	0000.0	0000.0
Load	0000.0 KN	0000.0	0000.0	0000.0	0000.0
Max	Min	CYL 5	CYL 6	CYL 7	CYL 8
Real Position	0000.0 mm	0000.0	0000.0	0000.0	0000.0
Relative Position	0000.0 mm	0000.0	0000.0	0000.0	0000.0
Load	0000.0 KN	0000.0	0000.0	0000.0	0000.0
MANUAL		SYNCHRO POSITION		LOAD MODE	
EXTEND	RETRACT	Delta Position	Final Load	RESET POSITION	
		0000.0 mm	0000.0 KN		

▲ PLC-controller station for ESS-Series synchronous lifting system.

▼ Offshore wind turbines levelling in the North Sea, Germany: Enerpac's hydraulic synchronous lifting system provided the solution for levelling the supporting cross pieces for 80 wind turbines of 5 MW each.



### ▼ Typical layout for a 4-point ESS-Series synchronous lifting system

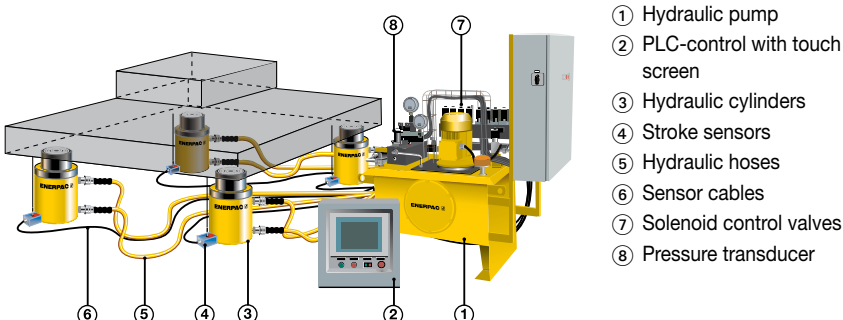



# Premium 4 to 64 Point Lifting System

## ▼ EPS-Series 4-point Premium Synchronous Lifting System



- Controls up to 64 lifting points
- Networking available to connect multiple systems
- Stroke, load and tilt controlled movement
- Hydraulic weighing and centre of gravity functions
- Dynamic load or stroke compensation
- Load and stroke alarms for optimal safety
- Pre-programmable movement
- Measurement accuracy better than  $\pm 0,25$  mm between leading and lagging cylinders
- Data storage, recording capabilities and graphic representation available
- For use with standard single- or double-acting cylinders
- Integrated 700 bar hydraulic pump and controls.



**Ideal for lifting applications requiring customised control features**



### Lifting an Unbalanced Load

Visit [www.enerpac.com](http://www.enerpac.com) to learn more about hydraulics and system set-ups.



### Contact Enerpac!

Contact the Enerpac office nearest to you for advice and technical assistance in the layout of your ideal Lift System. You can also ask Enerpac for assistance by email at: [integratedsolutions@enerpac.com](mailto:integratedsolutions@enerpac.com).



### EPS-Series Premium Synchronous Lifting Systems

The potential applications of this system are numerous. Synchronised lifting, lowering, pushing, pulling and positioning using computer technology and high-pressure hydraulics has become popular in many industries around the world.

The lifting or lowering capacity of this system is unlimited. By adding more or larger hydraulic cylinders to the setup, the system will allow jobs of 50.000 ton and more to be lifted with a high-level of safety and accuracy.

◀ Hydraulic lifting, weighing and manipulation system. During the lifting procedure the 16 point synchronous system operates within strict load and stroke constraints to ensure the desired load paths into the ship's hull structure are maintained. The various ship's hull segments up to 1300 tons are supported by the premium synchronous lifting system to confirm the design calculations.

# Premium 4 to 64 Point Synchronous Lifting System

▼ In tilting mode, each cylinder can be programmed to achieve a different stroke at the same time.

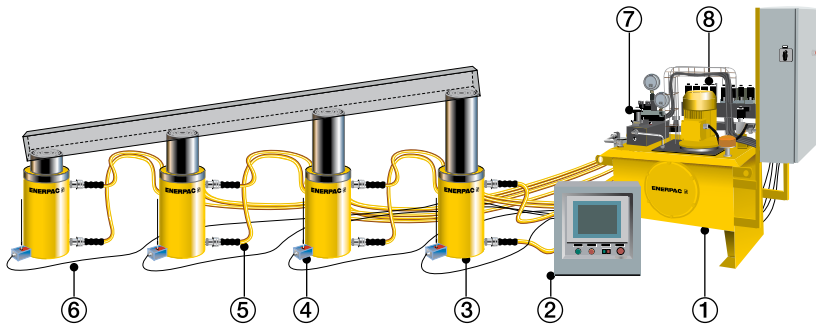

- ① Hydraulic pump
- ② PLC-control with touch screen
- ③ Hydraulic cylinders
- ④ Stroke sensors
- ⑤ Hydraulic hoses
- ⑥ Sensor cables
- ⑦ Solenoid control valves
- ⑧ Pressure transducer

## EPS Series



Number of Lifting Points:  
**4 to 64**

Accuracy Over Full Stroke:  
**± 0,25 mm**

Maximum Operating Pressure:  
**700 bar**

▼ Touch screen display of EPS Synchronous Lift Controller.

TOTAL LOAD		SYSTEM AUTO PAUSED !!!					
300000 lbs. x 1000							
Cylinders		C1	C2	C3	C4	C5	C6
Absolute position	<000.000	<000.000	<000.000	<000.000	<000.000	<000.000	inches
Relative position	<000.000	<000.000	<000.000	<000.000	<000.000	<000.000	lbs. x 1000
Load	<000.000	<000.000	<000.000	<000.000	<000.000	<000.000	inches
Delta position	<000.000	<000.000	<000.000	<000.000	<000.000	<000.000	inches
C7		C8	C9	C10	C11	C12	
Absolute position	<000.000	<000.000	<000.000	<000.000	<000.000	<000.000	inches
Relative position	<000.000	<000.000	<000.000	<000.000	<000.000	<000.000	lbs. x 1000
Load	<000.000	<000.000	<000.000	<000.000	<000.000	<000.000	inches
Delta position	<000.000	<000.000	<000.000	<000.000	<000.000	<000.000	inches
Mode Selection	MANUAL 0	AUTO LOAD 1	Manual				Speed
	AUTO POS 2	TITLING 3	UP				Auto Control Values
			DOWN				Delta position
			30000				inches
			30000				inches
			30000				lbs. x 1000
Data Record	START	STOP	RESET	Relative position Reset			



▲ PLC-controller station of the EPS-Series premium synchronous lifting system.

▼ One of the world's first and largest lifting jobs for maintenance of a 3500 ton mining dragline was successfully done with an Enerpac synchronous hydraulic system: exact aligning of bearings on the rail on which this dragline rotates.



▼ Millau Viaduct, France: Bridge lifting and launching system. The load is balanced on groups of CLL-Series lock nut cylinders. The hydraulic lifting, launching and balancing movements are synchronised with PLC-control.





# TT-Series, Heavy Lifting Strand Jacks

▼ Shown: TT-84SJ706, 86 ton Strand Jack



- Hydraulic wedge setting and wedge release for positive load control
- Individual strand guidance through jack
- Multi functional treatment for corrosion protection and trouble-free wedge release
- Jacks designed to be operated in all positions: vertical, horizontal or inclined
- Strand jack designed according to the highest safety standards with a minimum of 2,5:1 of strand breaking load
- Built-in sensors for closed-loop control.

▼ Heavy lifting system with 11 x 3720 kN Strand Jacks, 6 pumps, a master PLC-control system and network, for lifting roofs during the construction of a new triple bay aircraft maintenance hangar at Abu Dhabi International Airport.



## Lifting, lowering or horizontal movements of heavy loads



### Lifting in Unusual Situations

When loads need to be lifted or lowered in tight areas or in situations where overhead clearance is limited, Enerpac offers this economical alternative to traditional rigging equipment. Contact Enerpac: [integratedsolutions@enerpac.com](mailto:integratedsolutions@enerpac.com).



### Pre-stress Cap

Included with all strand jacks. Used for tensioning strand prior to operation.



### Strand Wedges

Specially designed wedges for use with Enerpac strand jacks are included and available to purchase separately.



### Heavy Lifting Accessories

- Lifting attachments
- Palm trees
- Strand recoilers
- Strand dispenser.

▼ Eight 444 ton strand jacks including palm trees, lifting attachments, strand recoilers and lifting wedge consumables will lift twelve ball mills weighing 1500 ton to a height of 20 metres onto their bearing housings at an Australia mining facility.





# Heavy Lifting Strand Jacks

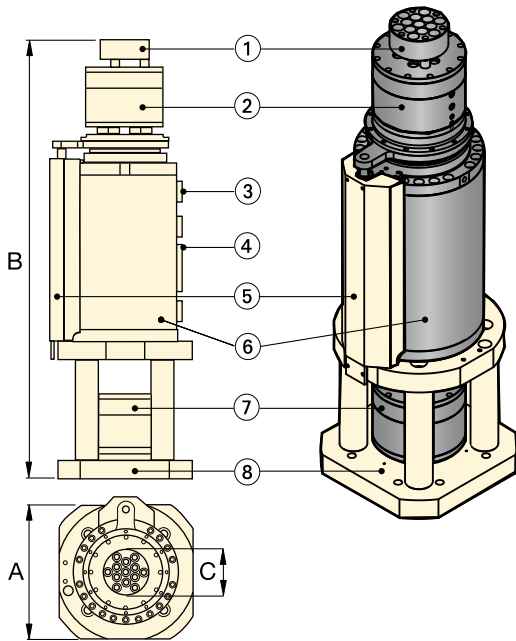

- ① Pre-Stress Cap
- ② Moving Lock Device
- ③ Pilot-Operated Check Valve
- ④ Electrical Connections
- ⑤ Stroke Sensor
- Anti Rotation Device
- ⑥ Lifting Cylinder
- ⑦ Static Lock Device
- ⑧ Chair

## TT Series



Rated Capacity per Jack:  
**37 - 673 ton**

Effective Stroke:  
**500 mm**

Working Pressure:  
**300 bar**

### Strand Jacking Lifting Sequence

The sequence of operation is illustrated with the lock devices shown in *red* when the wedges are closed. The lock devices are shown in *blue* when the wedges are open.

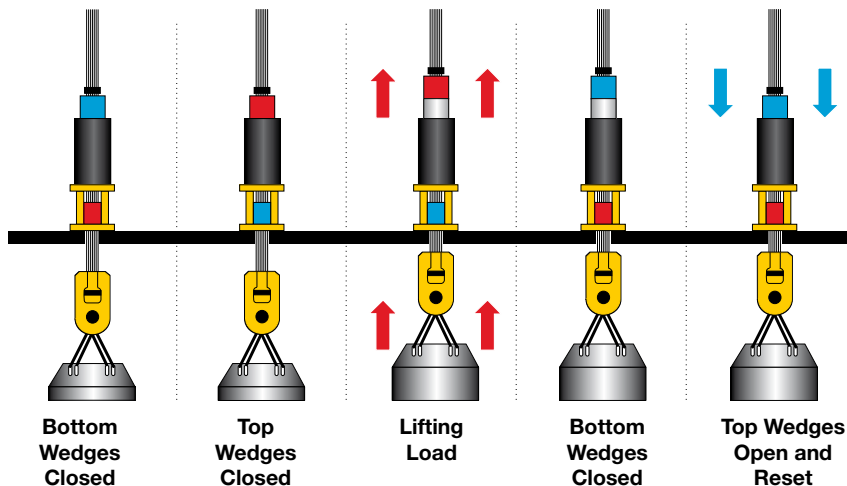

### PLC-Control Unit and Strand Jack Pumps

Using a network cable to interconnect each strand jack pump to the master control enables the use of an unlimited number of jacks.

Page: 11



### Mono Strand Lifting Jack

For heavy-lifting applications where a crane or hoist will not fit, the **ST-120M06** may be the only solution. Contact Enerpac for more details on this unique lifting solution.

### SELECTION CHART

Strand Jack Capacity <sup>1)</sup> ton (kN)	Model Number Strand Jack	Strand Diameter <sup>2)</sup> inch (mm)	Number of Strands	Effective Stroke (mm)	Effective Area (cm <sup>2</sup> )	Nominal Working Pressure (bar)	Dimensions (mm)		
							A	B (extended)	C
37 (360)	TT-36SJ306	0.60 (15,2)	3	500	123	300	300	2270	60
86 (840)	TT-84SJ706	0.60 (15,2)	7	500	287	300	430	2290	93
147 (1440)	TT-144SJ1206	0.60 (15,2)	12	500	466	300	490	2298	133
232 (2280)	TT-228SJ1906	0.60 (15,2)	19	500	754	300	600	2330	169
330 (3240)	TT-324SJ2706	0.60 (15,2)	27	500	1089	300	650	2330	208
453 (4440)	TT-444SJ3706	0.60 (15,2)	37	500	1486	300	700	2652	246
587 (5760)	TT-576SJ4806	0.60 (15,2)	48	500	1865	300	760	2693	284
673 (6600)	TT-660SJ5506	0.60 (15,2)	55	500	2199	300	900	2775	291

<sup>1)</sup> When used with compacted heavy lifting strand. Additional capacities and strokes are available.

<sup>2)</sup> Strand jacks are also available for 18,0 mm (0.70 inch) strand. Contact Enerpac for further information.

▼ Shown: TTP-Series, Strand Jack Hydraulic Pump



- Multiple pump and reservoir options
- PLC-controlled operation
- Steel frame and lifting eyes
- One pump per strand jack allows for short connections and flexible jack positions
- Pumps can be interconnected with a network cable.

#### Premium Options:

- Variable frequency drive for flow control and accurate synchronization between multiple lifting points
- One pump to operate multiple jacks
- Fully enclosed cabinet
- Oil cooler for operation in high temperature environments or continuous operation
- Reinforced cabinet with steel frame and lifting lugs
- Oil pre-heater in low temperature applications
- Biodegradable oil.

## Hydraulic Power for Demanding Strand Jacking Applications

Motor Size:

**5,5 - 37 kW**

Lifting Speed:

**1 - 29 m/hr**

Working Pressure:

**300 bar**



#### Hand Pendant

Allows individual control of strand jacks for set-up and manual operation. Included with each pump unit.



#### Contact Enerpac!

Contact the Enerpac office nearest to you for advice and technical assistance in the layout of your ideal Lifting System:  
**integratedsolutions@enerpac.com.**  
or visit: **www.enerpac.com.**



#### TT-Series Strand Jacks

Multi Strand Jacks for accurate lifting, lowering or horizontal movements of heavy loads.

Page:  **8**



▼ Two concrete arches of this viaduct in Silleda, Spain are rotated and lowered by Enerpac Heavy Lifting Strand Jacking Systems.





▼ Shown: Master PLC-Control Unit



- Modular based system
- Control up to 32 strand jacks with one master controller
- Multiple controllers can be networked
- Individual or synchronous control
- Individual and accumulative stroke and load display
- Stroke and load alarms for safety
- Data logging capabilities.

▼ Strand jack pumps and eight strand jacks are networked to the master PLC-controller to lift twelve ball mills, weighing 1500 ton each, at a mining facility in Australia. By using a network cable to interconnect each strand jack pump, multiple strand jacks can be operated from one master controller.



## Control Multiple Strand Jacks from One Master Controller

▼ Bridge launching with Enerpac Heavy Lifting Strand Jacks.



▼ Bridge launching with Enerpac Heavy Lifting Strand Jacks.



▼ Shown: BLS-506 in three lifting positions.



- Double-acting cylinder with solid plunger design
- Simple three-stage operation
- Swivel saddle and large support attachments for stability
- Anti-rotation device
- Built-in overload protection.
- Option: stroke sensors for use with Enerpac synchronous lifting systems
- Capacity per lifting point 50 - 200 ton. Other capacities and strokes available, please contact Enerpac.

▼ PLC-controlled hydraulic movement: Enerpac stage lift systems lift and lower the umbrella deck on the world's largest concrete block builder with 1,0 mm accuracy, provided by 30 hydraulic climbing units in an integrated hydraulic system. Each climbing unit consists of two 70 ton double-acting cylinders and two 20 ton locking cylinders.



## A Simple Solution to Incremental Lifting



### Lifting Height

Stage-lift cylinders overcome the usual limitation of lift height imposed by the cylinder's plunger stroke length. Large objects, such as oil tanks, can be lifted, held and lowered for maintenance without sending for a crane.



### Synchronous Lift System

Multi-cylinder arrangements can be powered and fully synchronized by Enerpac's Synchronous Lift System.

Page: 4

▼ Typical stage-lift application using a custom built Enerpac system to lift the 360 ton Akkerwinde wooden bridge in the Netherlands.





# Double-Acting Stage-Lift Cylinders



## Stage Lifting Application

For many lifting applications, the cylinder stroke can not be made long enough to lift the load to the required height. There is a direct relationship between the stroke length and the collapsed height of a cylinder. This relationship many times prevents a cylinder with the proper stroke length from also fitting in the required position to lift the load correctly. When these limitations are experienced, sometimes Stage-Lifting is the only solution.

Stage-Lifting is the process of lifting the load to the maximum stroke of

the cylinder and then “cribbing” or holding, the load at this point. Once this is done and the load is secure, the cylinder is retracted, cribbing is then placed under the cylinder and then the cycle is repeated. This stage-lifting cycle allows the load to be lifted many times the stroke of the cylinder and total height is only limited by the strength and stability of the cribbing system.

The BLS-Series of cylinders feature attachments that facilitate the cribbing application, by providing reaction points for both the load and the piston cribbing reaction points.

## BLS Series



Capacity per Lifting Point:

**50 - 200 ton**

Stroke per Stage:

**150 mm**

Maximum Operating Pressure:

**700 bar**

### ▼ Stage Lifting Sequence

**Step 1:** The Stage Lift cylinder is placed on a solid support under the load (retracted plunger).

**Step 2:** Plunger extends, lifting the load and giving clearance to insert two outer blocks under the spreading plate.

**Step 3:** Plunger retracts, giving clearance to position the central blocks which will support the plunger plate for the next extension.

**Step 4:** Plunger extends, lifting the load, giving clearance to insert two new blocks, placed crosswise under the spreading plate.

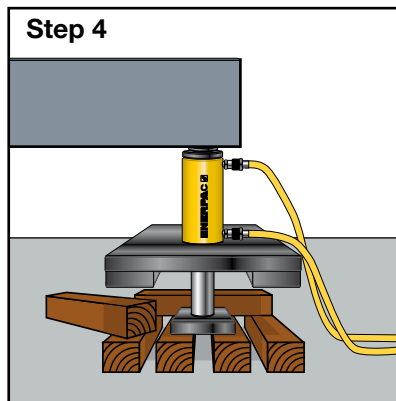
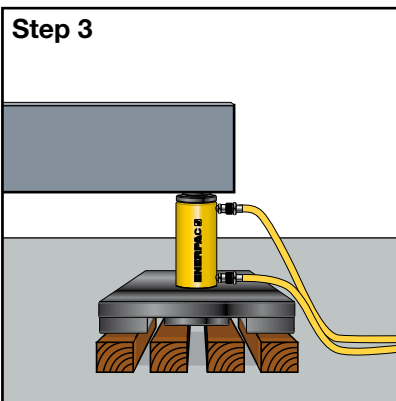
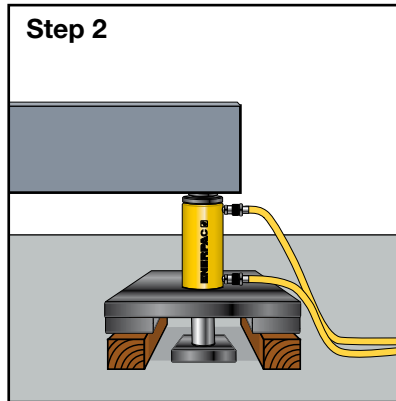
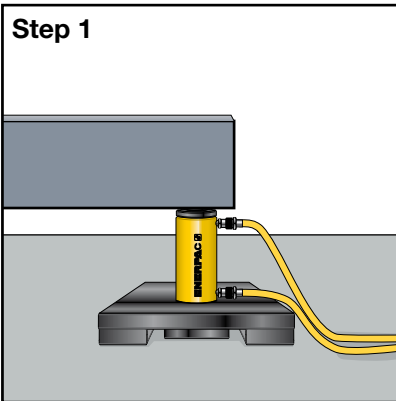

### Think Safety

Manufacturer's rating of load and stroke are maximum safe limits.

**Good practice encourages using only 80% of these ratings!**



### Lifting an Unbalanced Load?

See our “Yellow Pages” for multi-cylinder set-ups in our E326e catalogue or visit our learning centre on the website.

▼ Bridge maintenance with synchronous stage lifting systems. Two systems are networked to a PLC-controlled 8-point lift and crib system.



▼ SHS-Series 4-Point SyncHoist System



- High precision load manoeuvring, vertically and horizontally – using one crane
- Reduces the risk of damage from oscillations of wire rope due to sudden crane starts/stops
- Vastly improving operating speed and worker safety
- Weather conditions play less critical role
- Intelligent hydraulics turn lifting into high accuracy hoisting and load positioning system
- High accuracy (+/- 1,0 mm)
- 700 bar double-acting push/pull cylinders with parachute valves for added safety in case of hose rupture or coupler damage
- Cost reduction when compared to conventional load positioning methods.

**Options for system management & control:**

- Manual control: stroke control and system warning functions
- Extended manual control: stroke control, load and stroke display and system warning functions
- PLC-control: fully monitored system with programmable functions using touch screen and wireless remote control and system warning functions
- Contact Enerpac for stroke, capacity or control options.

## Accurate Hoisting and Load Positioning Enhancing a Crane's Capability



### Typical SyncHoist Functions and Applications

**Functions**

- High precision load positioning
- Pre-programmed positioning, tilting and aligning
- Counterweighing – determining centre of gravity.

**Applications**

- Positioning of roof sections, concrete elements, steel structures
- Positioning of turbines, transformers, fuel rods
- Precise machinery loading, mill rod changes, bearing changes
- Precise positioning of pipe lines, blow out valves
- Positioning and aligning of ship segments prior to assembly.

Visit [www.enerpac.com](http://www.enerpac.com) to learn more about SyncHoist and download the animation.

- ▼ Bridge segments are hoisted from the ground, being positioned with a 4-point SyncHoist system with fully monitored cylinders.





# SyncHoist - High Precision Load Positioning

## SHS-Series, Enerpac SyncHoist Systems

System Load Capacity	240 ton (2350 kN)	320 ton (3125 kN)	440 ton (4310 kN)
Max. handling load <sup>1)</sup>	4x60 ton	4x80 ton	4x110 ton
Number of lifting points <sup>2)</sup>	4	4	4
System reach	1500 mm	1500 mm	1500 mm
<b>Cylinder configuration</b>			
Push force @ 90 bar	10,5 ton	14,0 ton	22,0 ton
Pull force @ 700 bar	60,0 ton	80,0 ton	110,0 ton
Plunger stroke <sup>2)</sup>	1500 mm	1500 mm	1500 mm
<b>Pump single-stage</b>			
Oil flow at 700 bar	4,0 l/min	4,0 l/min	4,0 l/min

### Control options & system management <sup>3)</sup>

Manual control	Manual directional control valves
Extended manual control	Joystick controls with position display
PLC-control <sup>4)</sup>	Fully closed-loop control system

- <sup>1)</sup> Subject to angle and position of lifting cylinders.  
<sup>2)</sup> Each cylinder equipped with parachute valve for added safety in event of hose/coupler damage.  
 Note: Enerpac SyncHoist have standard 4 lifting points. In the event that more or less lifting points are required, contact your local Enerpac representative.  
<sup>3)</sup> See chart below for detailed control features.  
<sup>4)</sup> Required for counterweighing (centre of gravity).

## SHS Series



Capacity Per Lifting Point:

**60 - 110 ton**

Maximum Stroke:

**1500 mm**

Accuracy Over Full Stroke:

**± 1,0 mm**

Maximum Operating Pressure:

**700 bar**



▲ *Perfectly synchronised balance: Naval ship superstructure weighing over 600 tons placed on the hull using Enerpac's hydraulic SyncHoist.*

▼ *Designs of Santiago Calatrava (architect) often require creative technological solutions. Enerpac SyncHoist System is one of them and was used for roof positioning of the Palace of the Arts in Valencia (Spain). Segments are hoisted from the ground, being positioned with four fully monitored cylinders.*



### Three options for system management and control

Contact Enerpac for the following options, or other customised stroke, capacity and control configurations.

#### 1. Manual control

- Plunger stroke control
- System warnings for:
  - oil level, filter indication, thermal motor protection.

#### 2. Extended manual control

- Plunger stroke control
- Load & stroke display
- System warnings for:
  - maximum cylinder load control setting
  - oil level, filter indication, thermal motor protection.

#### 3. PLC-control

- Touch screen
- Remote wireless radio control
- Load and stroke monitoring
- Load calculations (centre of gravity)
- Pre-programmable motions and data recording
- System warnings for:
  - maximum cylinder load control setting
  - stroke and position control
  - oil level, filter indication, thermal motor protection.

▼ Shown: Uni-Lift® Mechanical Actuators



- Machine screw versions up to 250 ton for low-cycle, high-load applications and positive load holding
- Ball-Screw versions up to 5 tons for high-cycle, high-speed applications
- Electro-Mechanical Drive System can be interlinked and easily synchronized
- Precision rolled load screws Class 3 fit for additional strength
- Preloaded tapered roller bearings tolerate high thrust loads and minimize side loading
- Precision machine gear sets provide minimum backlash while reducing wear
- Wide variety of base-mounting and screw-end configurations.

## Precision Positioning and Control in a Mechanical Package



### Maximize Your System Control

Custom control boxes designed to meet your specific application requirements.



### System Accessories

Enerpac offers a large array of motors, drive components, and boots to meet any demanding project.



◀ *Uni-Lift® Actuators were the ideal choice to position and adjust the complex scaffolding for aircraft maintenance. Precision movement and flexibility was an asset in getting the job done efficiently and safely.*

# Uni-Lift® Mechanical Actuators



Ball Screw Cutaway



Machine Screw Cutaway

## B, M Series



Capacity:

**2,2 - 2222 kN**

Maximum Stroke:

**380 - 6095 mm**

Actuator Types:

**Machine & Ball Screw**

### Design Features:

- Available with translating, rotating and keyed load screw designs
- High-strength rolled load screws provide maximum durability
- Rugged aluminum alloy and ductile iron housings for demanding or rigorous environment
- Corrosion resistant zinc plating is standard on most units
- The widest range options gear ratios are available to meet all application requirements
- Speeds up to 0,17 m/sec.

### Actuator Accessories:

- High-quality bellow boots for added loadscrew protection
- Easy mounting of optional screw ends are available in plain, top plate and clevis design
- Wide selection of motors and C-face adaptors
- Limit switches and encoders for complete system control
- Couplers and shafting available for individual system requirements
- A large choice of mitre gear boxes and reducers provide maximum system design flexibility
- Custom built control boxes to meet your specific need.



### Over-travel Stop Nuts

Provide a mechanical stop and are used to prevent the ejection of the power screw from the actuator.



### CAD Modeling Software

Our experienced sales team and application engineers will deliver the precise support you need to meet the most demanding and unique requirements. State-of-the-art CAD modeling software offers the needed flexibility to design custom built "special" screw jacks to suit all customer needs. See Uni-Lift® Solutions in Action.

Page: 18

### Typical Mechanical Actuator Set-Up

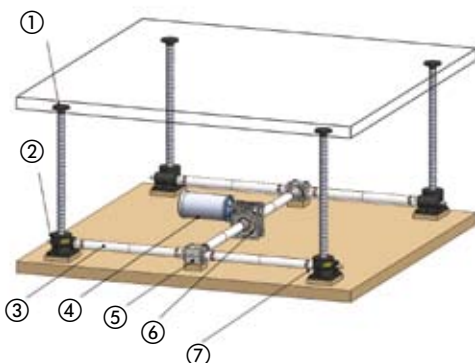

- ① Top Plate (4x)
- ② Uni-Lift® Mechanical Actuator (4x)
- ③ Shafting (6x)
- ④ Electric Motor (1x)
- ⑤ Mitre Gearbox (2x)
- ⑥ Reducer (1x)
- ⑦ Coupler (1x)



### Contact Enerpac!

Contact the Enerpac office nearest to you for advice and technical assistance in the layout of your ideal Lifting System or visit us at: [www.enerpac.com](http://www.enerpac.com).  
Or ask Enerpac for assistance by email: [integratedsolutions@enerpac.com](mailto:integratedsolutions@enerpac.com).



## Precision Positioning and Control in a Mechanical Package.

### Actuators move the ramp of ferry dock ►

Engineers utilized two (2) Uni-Lift® 100-ton actuators with 5 metres of travel to raise and lower the ramp on each ferry dock along the Mississippi River, USA. The Department of Transportation engineers needed a way of lifting and lowering ramps during high and low tide conditions, while holding up to the harsh environmental conditions of the gulf coast.



### ◀ Opening large doors of plating tanks

When engineers needed a quick and compact way of opening the large doors of these large plating tanks, they contacted Uni-Lift® for help. This application utilizes two 5-ton double-clevis actuators, with a motor and a limit switch box mounted on each actuator. The operator just pushes a button to open the doors, and pushes another button to close them. This method greatly enhances operator safety and helps to prevent cross contamination between tanks.

### OEM motion control solutions ►

Uni-Lift® screw jacks are used extensively in a variety of material handling applications. Whether used in positioning conveyer belts, placing tension on overhead beams or moving heavy-duty equipment, Uni-Lift® actuators are the ideal solution for many jackings, tensionings, and positioning applications. Whether you have one lifting point or multiple lifting points, Uni-Lift® actuators are the perfect solution for many different OEM motion control applications.





ENERPAC manufactures high-force hydraulics (cylinders, pumps, valves, presses, pullers, tools, accessories and system components) for industry and construction and provides hydraulic workholding and OEM solutions to industries worldwide.

With an 80-year history of quality and innovation, the broadest line in the business, and more than 4000 distributors and factory-trained service centers around the world, Enerpac leads the industry by setting new standards in design, strength, durability and local support. Strict quality programs, zero tolerance for defects, and ISO-9001 certification are your assurance of safe, trouble-free operation.

Enerpac is ready to tackle your toughest challenge and provide the hydraulic advantage you need to increase productivity, labour efficiency and speed of operation.

While every care has been taken in the preparation of this catalogue and all data contained within is deemed accurate at the time of printing, Enerpac does reserve the right to make changes to the specifications of any product, or discontinue any product, contained within this catalogue without prior notice.

All illustrations, performance specifications, weights and dimensions reflect the nominal values and slight variations may occur due to manufacturing tolerances. Please consult Enerpac if final dimensions are critical. All information in this catalogue can be changed due to product improvements without prior notice.

© Copyright 2010, Enerpac.  
All rights reserved. Any copying or other use of material in this catalogue (text, illustrations, drawings, photo's) without express written consent is prohibited.

### Worldwide Catalogue Coverage

Enerpac Catalogues are printed in many languages. If your requirements call for product use in a different country, please send your request to the applicable country listed on the backpage or [www.enerpac.com](http://www.enerpac.com) – the Enerpac catalogue of the country serving your specific market area will be forwarded promptly.

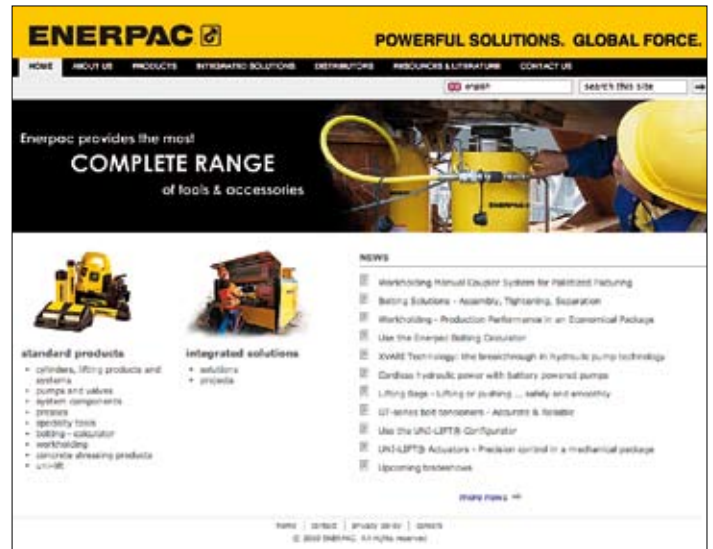
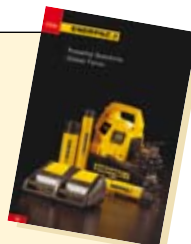

### www.enerpac.com for latest Enerpac information

Visit the Enerpac Web Site:

- Learn more about hydraulics
- Promotions
- New products
- Electronic Catalogs
- Trade shows
- Manuals (instruction and repair sheets)
- Nearest Distributors & Service Centers
- Enerpac products in action
- Integrated Solutions.

### Ordering Products and Catalogs

To find the name of the closest Enerpac distributor or service center, to request literature or technical application assistance, contact Enerpac at one of the addresses on the next page or pose your question through E-mail: [info@enerpac.com](mailto:info@enerpac.com)

### Enerpac catalogues & brochures to meet your needs:

To obtain your copy just give us a call, or visit our Internet site.

#### E410e, Bolting Solutions Catalogue

Caters to the complete bolting workflow, ensuring joint integrity in a variety of applications throughout industry, including: joint assembly, controlled tightening and joint separation.



#### 8200 GB, Solutions & Systems for the Wind Power Industry

Enerpac is the natural choice for providing tools, solutions and systems to the wind power industry. Capability brochure about core technologies: High-force industrial tools, bolting solutions and integrated positioning systems.



#### E213e, Workholding Catalogue

Offers innovative products and solutions to provide powerful clamping and positioning force to every type of manufacturing process. Workholding solutions increase product quality and production output.



# Enerpac Integrated Solutions



## Enerpac Worldwide Locations

### Africa

ENERPAC Middle East FZE  
Office 423, JAFZA 15  
P.O. Box 18004  
Jebel Ali, Dubai  
United Arab Emirates  
Tel: +971 (0)4 8872686  
Fax: +971 (0)4 8872687

### Australia and New Zealand

Actuant Australia Ltd.  
Block V Unit 3  
Regents Park Estate  
391 Park Road  
Regents Park NSW 2143  
(P.O. Box 261) Australia  
Tel: +61 297 438 988  
Fax: +61 297 438 648

### Brazil

Power Packer do Brasil Ltda.  
Rua dos Inocentes, 587  
04764-050 - Sao Paulo (SP)  
Tel: +55 11 5687 2211  
Fax: +55 11 5686 5583  
Toll Free: 0800 891 5770  
vendasbrasil@enerpac.com

### Canada

Actuant Canada Corporation  
6615 Ordan Drive, Unit 14-15  
Mississauga, Ontario L5T 1X2  
Tel: +1 905 564 5749  
Fax: +1 905 564 0305  
Toll Free:  
Tel: +1 800 268 4987  
Fax: +1 800 461 2456  
Technical Inquiries:  
techservices@enerpac.com

### China

Actuant Industries Co. Ltd.  
No. 6 Nanjing Road,  
Taicang Economic Dep Zone  
Jiangsu, China  
Tel: +86 0512 5328 7529  
+86 0512 5328 7500  
Fax: +86 0512 5335 9690

### Actuant China Ltd. (Peking)

709B Diyang Building  
Xin No. 2  
Dong San Huan North Rd.  
Beijing City, 100028 China  
Tel: +86 10 845 36166  
Fax: +86 10 845 36220

### France and Switzerland

ENERPAC Une division de  
ACTUANT France S.A.S.  
ZA de Courtaboeuf  
32, avenue de la Baltique  
91140 VILLEBON /VETTE  
France  
Tel: +33 1 60 13 68 68  
Fax: +33 1 69 20 37 50

### Germany, Austria, Greece, Baltic States, Central and Eastern Europe

ENERPAC GmbH  
P.O. Box 300113  
D-40401 Düsseldorf  
Willstätterstrasse 13  
D-40549 Düsseldorf, Germany  
Tel: +49 211 471 490  
Fax: +49 211 471 49 28

### India

ENERPAC Hydraulics Pvt. Ltd.  
No. 1A, Peenya Industrial Area  
II<sup>nd</sup> Phase, Bangalore, 560 058  
India  
Tel: +91 80 40 792 777  
Fax: +91 80 40 792 792

### Italy

ENERPAC S.p.A.  
Via Canova 4  
20094 Corsico (Milano)  
Tel: +39 02 4861 111  
Fax: +39 02 4860 1288

### Japan

Applied Power Japan LTD KK  
Besshocho 85-7  
Kita-ku, Saitama-shi 331-0821, Japan  
Tel: +81 48 662 4911  
Fax: +81 48 662 4955

### Middle East, Turkey and Caspian Sea

ENERPAC Middle East FZE  
Office 423, JAFZA 15  
P.O. Box 18004, Jebel Ali, Dubai  
United Arab Emirates  
Tel: +971 (0)4 8872686  
Fax: +971 (0)4 8872687

### Russia and CIS

(excl. Caspian Sea Countries)  
Actuant LLC  
Admiral Makarov Street 8  
125212 Moscow, Russia  
Tel: +7-495-9809091  
Fax: +7-495-9809092

### Singapore

Actuant Asia Pte Ltd.  
37C, Benoi Road Pioneer Lot,  
Singapore 627796  
Tel: +65 68 63 0611  
Fax: +65 64 84 5669  
Toll Free: Tel: +1800 363 7722  
Technical Inquiries:  
techsupport@enerpac.com.sg

### South Korea

Actuant Korea Ltd.  
3Ba 717, Shihwa Industrial Complex  
Jungwang-Dong, Shihung-Shi,  
Kyunggi-Do  
Republic of Korea 429-450  
Tel: +82 31 434 4506  
Fax: +82 31 434 4507

### Spain and Portugal

ENERPAC SPAIN, S.L.  
Avda. Los Frailes,  
40 - Nave C & D  
Pol. Ind. Los Frailes  
28814 Daganzo de Arriba  
(Madrid) Spain  
Tel: +34 91 884 86 06  
Fax: +34 91 884 86 11

### Sweden, Denmark, Norway, Finland and Iceland

Enerpac Scandinavia AB  
Fabriksgatan 7  
412 50 Gothenburg  
Sweden  
Tel: +46 (0) 31 7990281  
Fax: +46 (0) 31 7990010  
Inquiries:  
Scandinavianinquiries@enerpac.com

### The Netherlands, Belgium and Luxembourg

ENERPAC B.V.  
Galvanistraat 115  
6716 AE Ede  
P.O. Box 8097  
6710 AB Ede  
The Netherlands  
Tel: +31 318 535 800  
Fax: +31 318 525 613  
+31 318 535 848

Inquiries:  
beneluxinquiries@enerpac.com

### ENERPAC Roermond B.V.

Daalackerweg 24  
6041 BL Roermond  
P.O. Box 49  
6040 AA Roermond  
The Netherlands  
Tel: +31 475 355 000  
Fax: +31 475 331 774

### United Kingdom and Ireland

ENERPAC Ltd.,  
Bentley Road South  
Darlaston, West Midlands  
WS10 8LQ, England  
Tel: +44 (0)121 50 50 787  
Fax: +44 (0)121 50 50 799

### USA, Latin America and Caribbean

ENERPAC  
P.O. Box 2041

6700

M

W

T

F

U

D

T

te

**TIFOR Kft.**

**Attila u. 101.**

**1012 Budapest**

**tel 06 1 212 99 58**

**fax 06 1 375 49 79**

**eMail info@tifor.hu**

**www.tifor.hu**

info@enerpac.com

www.enerpac.com

Your Enerpac Dist